



# Toyota Supra L6-3.0L DOHC (2JZ-GE) 1994

## Timing Belt: Service and Repair

### Timing Belt Removal

#### REMOVAL

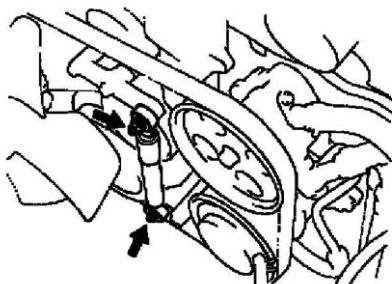

1. REMOVE RADIATOR ASSEMBLY
2. 2 JZ-GTE M/T :  
REMOVE DRIVE BELT TENSIONER DAMPER  
Remove the 2 nuts and tensioner damper.
3. REMOVE DRIVE BELT, FAN, FLUID COUPLING ASSEMBLY AND WATER PUMP PULLEY
4. REMOVE NO.3 TIMING BELT COVER



- (a) Remove the oil filler cap.
- (b) 2 JZ-GE :  
Using a 5 mm hexagon wrench, remove the 6 bolts and belt cover.

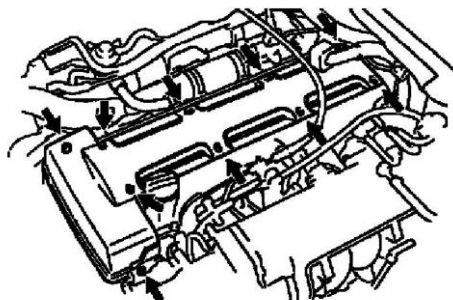

- (c) 2 JZ-GTE :  
Using a 5 mm hexagon wrench, remove the 10 bolts and belt cover.

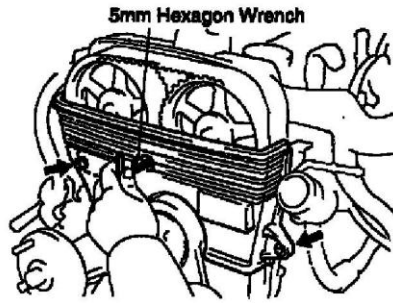

5. REMOVE NO.2 TIMING BELT COVER

Using a 5 mm hexagon wrench, remove the 3 bolts, belt cover and gasket.

If you are unable to loosen the bolt on the right because the PS pump pulley interferes with the hexagon wrench, first remove the pulley.

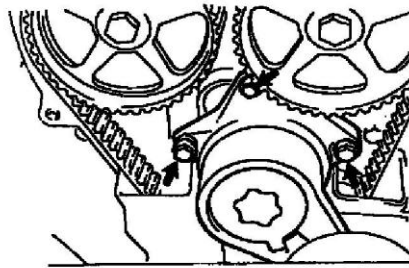

6. REMOVE DRIVE BELT TENSIONER

Remove the 3 bolts and tensioner.

7. SET NO.1 CYLINDER TO TDC/COMPRESSION

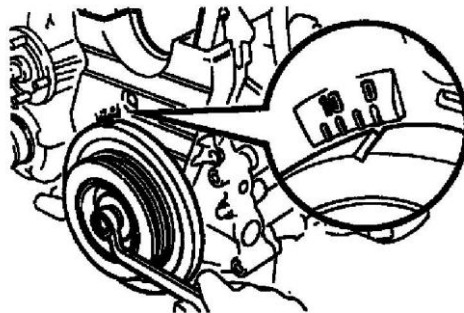

(a) Turn the crankshaft pulley, and align its groove with timing mark "0" of the No.1 timing belt cover.

NOTICE: Always turn the crankshaft clockwise.

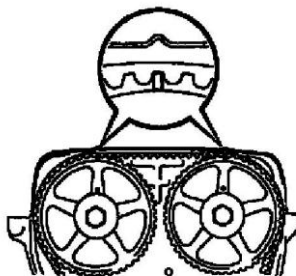

(b) Check that the timing marks of the camshaft timing pulleys are aligned with the timing marks of the No.4 timing belt cover. If not, turn the crankshaft 1 revolution (380°).

8. REMOVE TIMING BELT FROM CAMSHAFT TIMING PULLEYS

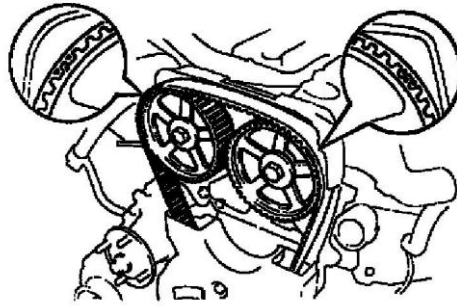

HINT (Re-using timing belt): Place matchmarks on the timing belt and camshaft timing pulleys as shown in the illustration.

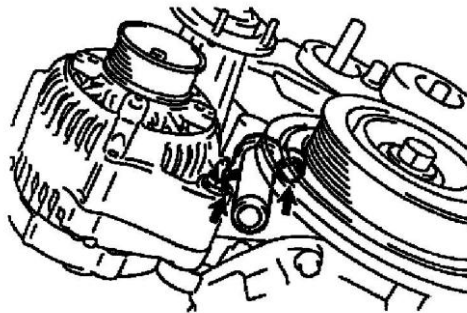

(a) Alternately loosen the 2 bolts, and remove them, the tensioner and dust boot.



(b) Disconnect the timing belt from the camshaft timing pulleys.

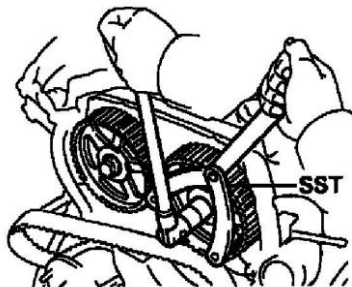

9. REMOVE CAMSHAFT TIMING PULLEYS

Using SST. remove the pulley bolt. Remove the 2 timing pulleys. SST 09960-10010 (09962-01000, 09963-01000)

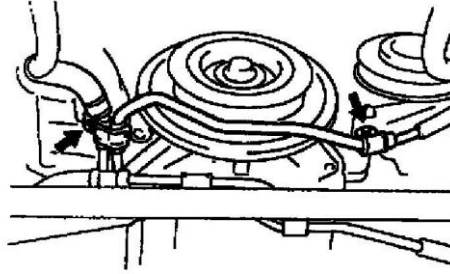

10. A/T:  
DISCONNECT OIL COOLER TUBES  
Remove the 2 bolts and hose clamps, and disconnect oil cooler tubes.

11. REMOVE CRANKSHAFT PULLEY

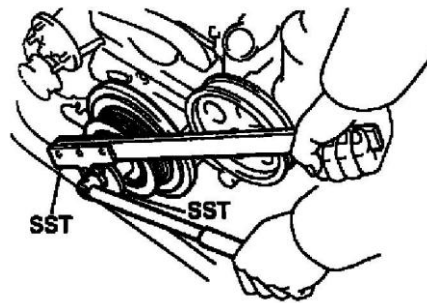

- (a) Using SST, loosen the pulley bolt. SST 09213-70010,09330-00021 (b) Remove the pulley bolt.

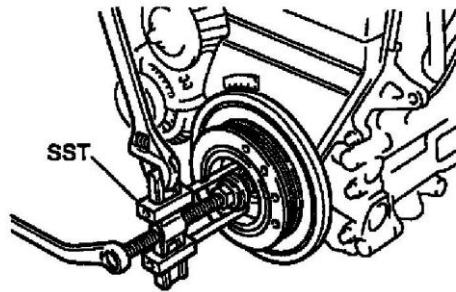

- (c) Using SST, remove the pulley. SST 09950-50010 (09954-05030. 09551-05010, 09552-05010. 09553-05020)

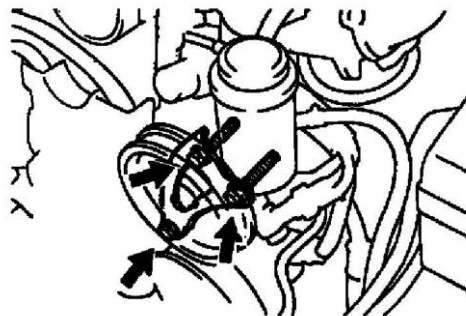

12. 2 JZ-GE :  
REMOVE PS PUMP FRONT BRACKET  
Remove the 3 bolts, plate washer and pump front bracket.

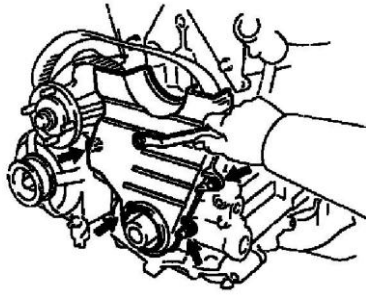

13. REMOVE NO.1 TIMING BELT COVER

Remove the 5 bolts, timing belt cover and gasket.

14. REMOVE TIMING BELT GUIDE

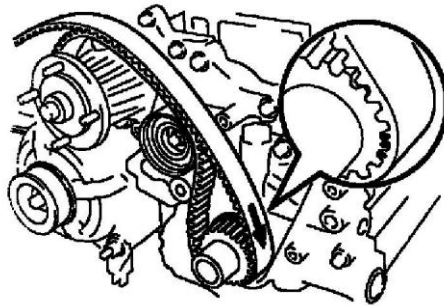

15. REMOVE TIMING BELT

HINT (When re-using timing belt): Draw an arrow on the timing belt in the direction of engine revolution, and place matchmarks on the timing belt and crankshaft timing pulley.

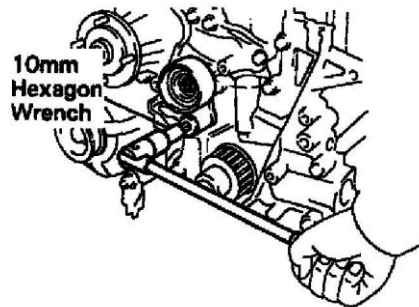

16. REMOVE IDLER PULLEY

Using a 10 mm hexagon wrench, remove the pivot bolt, plate washer and idler pulley.

17. REMOVE CRANKSHAFT TIMING PULLEY

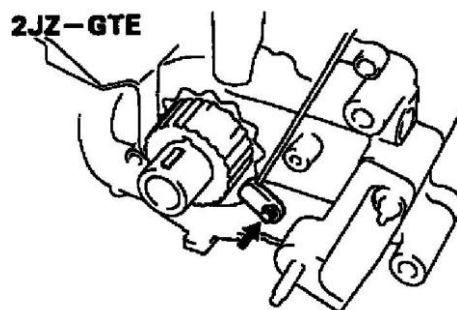

(a) 2 JZ-GTE :

Remove the bolt and timing belt plate.

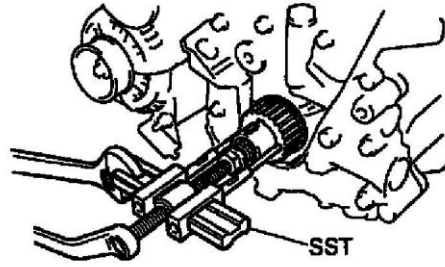

(b) Remove the crankshaft timing pulley.

If the pulley cannot be removed by hand, use SST to remove the crankshaft timing pulley. SST 09950-50010 (09951 - 05010, 09952 05010 , 09953 - 05020, 09954 - 00010)

# Timing Belt: Service and Repair

## Timing Belt Installation

### INSTALLATION

#### 1. INSTALL CRANKSHAFT TIMING PULLEY

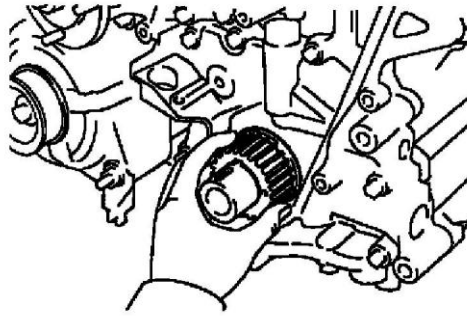

- (a) Align the pulley set key with the key groove of the pulley. (b) Slide on the timing pulley facing the flange side inward.

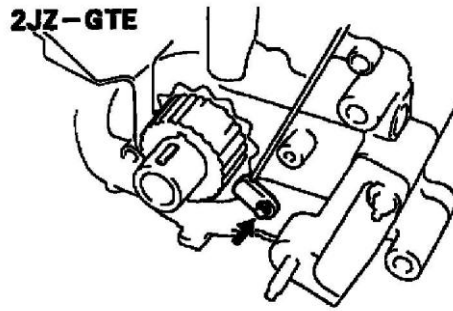

- (c) 2 JZ-GTE :  
Install the timing belt plate with the bolt.

Torque: 7.8 N.m (80 kgf.cm, 69 in.lbf)

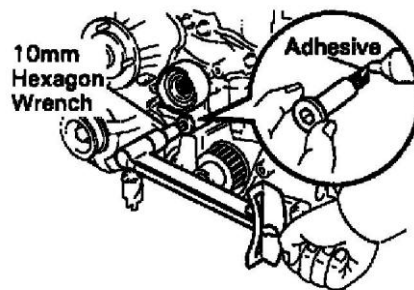

#### 2. INSTALL IDLER PULLEY

- (a) Apply adhesive to 2 or 3 threads of the pivot bolt.

Adhesive:

Part No.08833-00080, THREE BOND 1344. LOCTITE 242 or equivalent

- (b) Using a 10 mm hexagon wrench, install the plate washer and pulley with the pivot bolt.

Torque: 34 N.m (350 kgf.cm, 25 ft.lbf)

- (c) Check that the pulley bracket moves smoothly.

3. TEMPORARILY INSTALL TIMING BELT  
NOTICE: The engine should be cold.

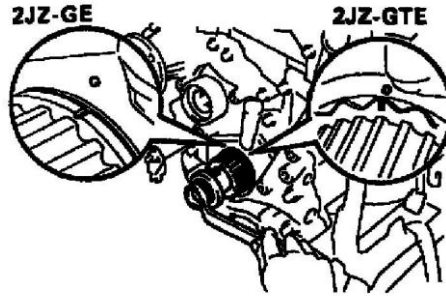

- (a) Using the crankshaft pulley bolt, turn the crankshaft, and align the timing marks on the crankshaft timing pulley and on the oil pump body.
- (b) Remove any oil or water on the crankshaft timing pulley and idler pulley, and keep them clean.

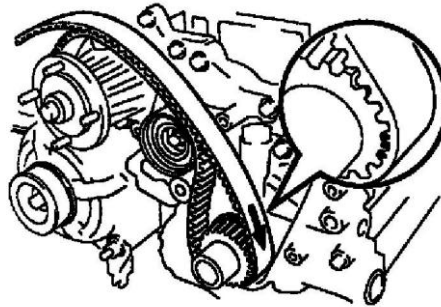

- (c) Install the timing belt on the crankshaft timing pulley and idler pulley.

HINT (When re-using timing belt): Align the match marks of the crankshaft timing pulley and timing belt, and install the belt with the arrow pointing in the direction of engine revolution.

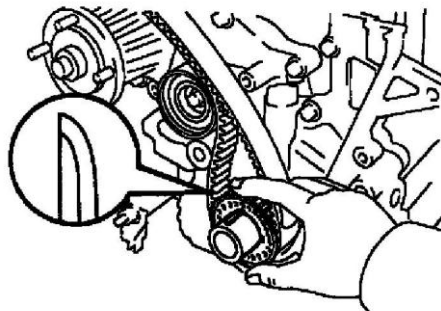

4. INSTALL TIMING BELT GUIDE

Install the guide, facing the cup side outward.

5. INSTALL NO.1 TIMING BELT COVER





6. 2 JZ-GE :

INSTALL PS PUMP FRONT BRACKET

- (a) Install the pump front bracket with the 2 bolts (A).

Torque: 58 N.m (590 kgf.cm. 43 ft.lbf)

- (b) Install the plate washer and bolt (B) to the oil pump.

Torque: 52 N.m (530 kgf.cm. 38 ft.lbf)

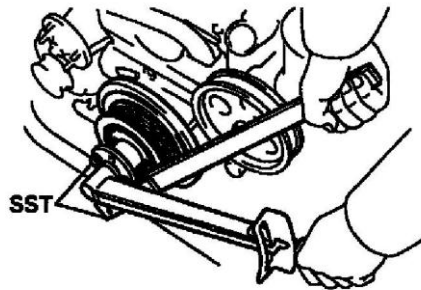

7. INSTALL CRANKSHAFT PULLEY

- (a) Align the pulley set key with the key groove of the pulley, and slide on the pulley.  
(b) Using SST, install the bolt. SST 09213-70010.09330-00021

Torque: 324 N.m (3.300 kgf.cm. 239 ft.lbf)

8. A/T:

CONNECT OIL COOLER TUBES

9. INSTALL CAMSHAFT TIMING PULLEYS

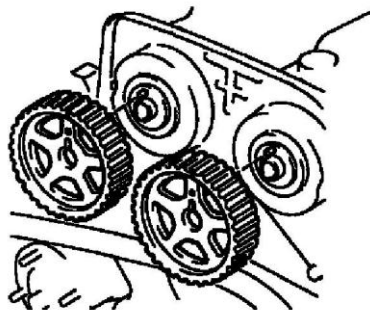

- (a) Align the camshaft knock pin with the groove of the pulley, and slide on the timing pulley. (b) Temporarily install the timing pulley bolt.

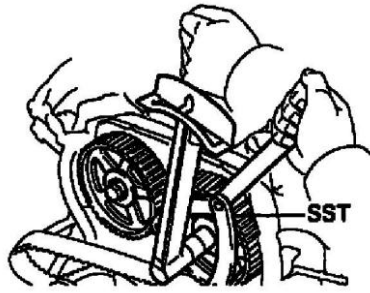

(c) Using SST, tighten the pulley bolt. SST 09960-10010 (09962-01000. 09963-01000)

Torque: 79 N.m (810 kgf.am. 59 ft.lbf)

#### 10. SET NO.1 CYLINDER TO TDC/COMPRESSION

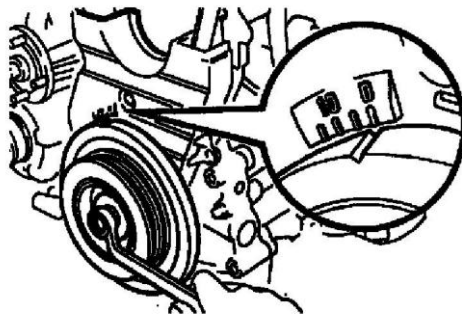

(a) Turn the crankshaft pulley, and align its groove with timing mark "0" of the No.1 timing belt cover.

NOTICE: Always turn the crankshaft clockwise.

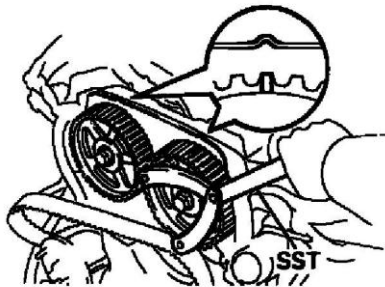

(b) Using SST, align the timing marks of the camshaft timing pulleys and No.4 timing belt cover. SST 09960-10010 (09962-01000. 09963-01000)

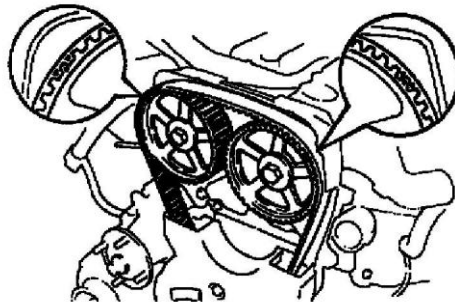

#### 11. INSTALL TIMING BELT

HINT (When re-using timing belt): Align the match-marks of the timing belt and camshaft timing pulleys.

- (a) Remove any oil or water on the camshaft timing pulley, and keep it clean.
- (b) Install the timing belt, checking the tension between the crankshaft timing pulley and exhaust camshaft timing pulley.

12. SET TIMING BELT TENSIONER

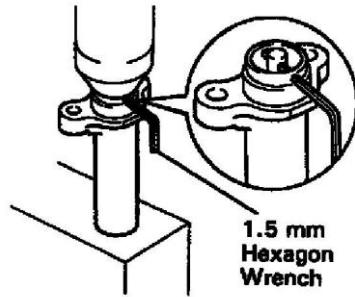

- (a) Using a press, slowly press in the push rod using 981 - 9.807 N (100 - 19000 kgf. 220 - 2.205 lbf) of force.
- (b) Align the holes of the push rod and housing, pass a 1.5 mm hexagon wrench through the holes to keep the push rod retracted.
- (c) Release the press.

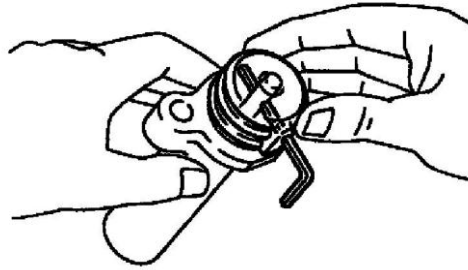

- (d) Install the dust boot onto the tensioner.

13. INSTALL TIMING BELT TENSIONER

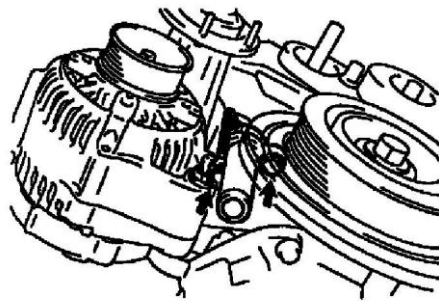

- (a) Temporarily install the tensioner with the 2 bolts. (b) Alternately tighten the 2 bolts.

Torque: 26 N.m (270 kgf.cm. 20 ft.lbf)

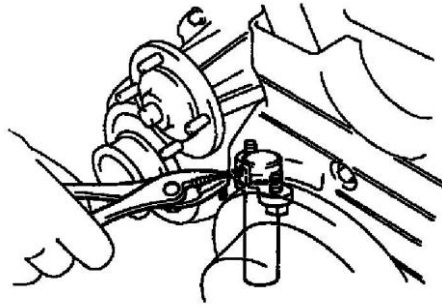

(c) Remove the 1.5 mm hexagon wrench from the tensioner.

#### 14. CHECK VALVE TIMING

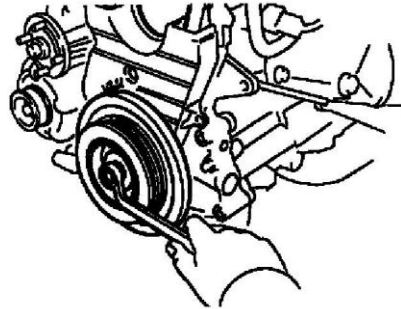

(a) Slowly turn the crankshaft pulley 2 revolutions from TDC to TDC.

NOTICE: Always turn the crankshaft clockwise.

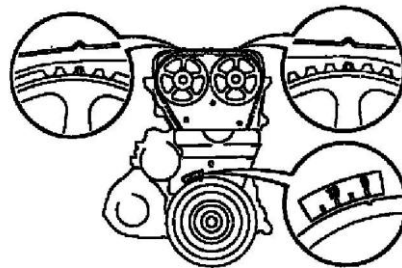

(b) Check that each pulley aligns with the timing marks as shown in the illustration. If the marks do not align, remove the timing belt and reinstall it.

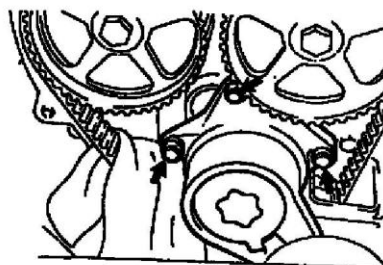

#### 15. INSTALL DRIVE BELT TENSIONER

Install the tensioner with the 3 bolts.

Torque: 21 N.m (210 kgf.cm, 15 ft.lbf)

NOTICE: Be careful not to drop the bolts inside the timing belt cover.

16. INSTALL NO.2 TIMING BELT COVER
17. INSTALL NO.3 TIMING BELT COVER
18. INSTALL WATER PUMP PULLEY, FAN, FLUID COUPLING ASSEMBLY AND DRIVE BELT
19. 2 JZ - GTE M/T :  
INSTALL DRIVE BELT TENSIONER DAMPER  
  
Torque: 20 N.m (200 kgf.cm. 14 ft.lbf)
20. INSTALL RADIATOR ASSEMBLY
21. ROAD TEST VEHICLE  
Check for abnormal noise, shock, slippage, correct shift points and smooth operation.