



Toyota Truck Highlander 2WD V6-3.0L (1MZ-FE) 2002

Timing Belt: Service and Repair

REPLACEMENT

1. REMOVE FRONT WHEEL RH
2. REMOVE FRONT FENDER APRON SEAL RH
3. REMOVE V (COOLER COMPRESSOR TO CRANKSHAFT PULLEY) BELT NO. 1
4. REMOVE VANE PUMP V BELT
5. REMOVE ENGINE MOVING CONTROL ROD
6. REMOVE ENGINE MOUNTING STAY NO. 2 RH
7. REMOVE GENERATOR BRACKET NO. 2 8. REMOVE CRANKSHAFT PULLEY

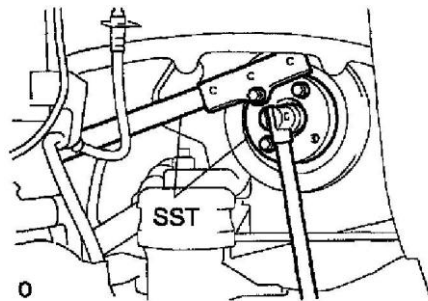

- a. Using SST, loosen the pulley bolt.
SST 09213-54015 (91651-60855), 09330-00021

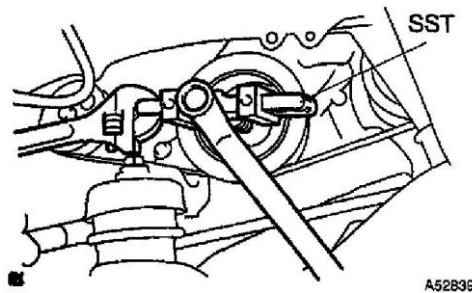

- b. Using SST and the pulley bolt, remove the pulley.
SST 09950-50013 (09951-05010, 09952-05010, 09953-05010, 09954-05030)

NOTICE: Before using SST, apply lubricating oil on the threads and tip of the center bolt
100.

9. REMOVE TIMING BELT NO. 1 COVER

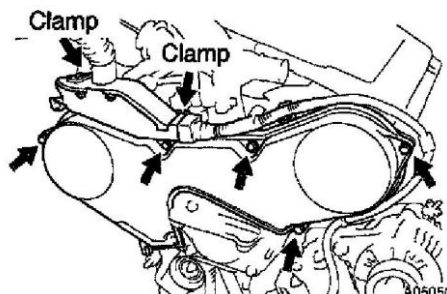

10. REMOVE TIMING BELT NO. 2 COVER

- a. Disconnect the engine wire protector clamps from the timing belt No. 3 cover.
 - b. Remove the 5 bolts and timing belt cover.
11. REMOVE TRANSVERSE ENGINE ENGINE MOUNTING BRACKET
12. REMOVE TIMING BELT GUIDE NO. 2
13. REMOVE TIMING BELT
- a. Set No. 1 cylinder to TDC/compression.
 - 1. Temporarily install the crankshaft pulley bolt with the washer to the crankshaft.

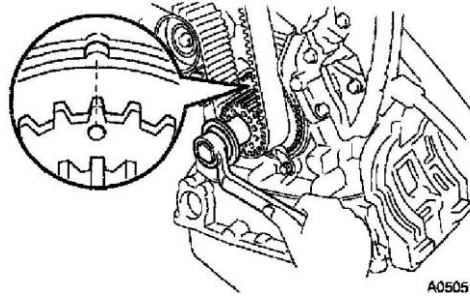

- 2. Turn the crankshaft clockwise, and align the timing marks of the crankshaft timing pulley and oil pump body.

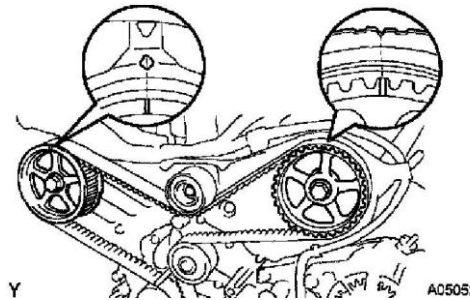

- 3. Check that timing marks of the camshaft timing pulleys and No. 3 timing belt cover are aligned. If not, turn the crankshaft 1 revolution (360°).
 - 4. Remove the crankshaft pulley bolt.
- b. Remove the timing belt tensioner.

NOTICE: Do not install the tensioner as it removed.

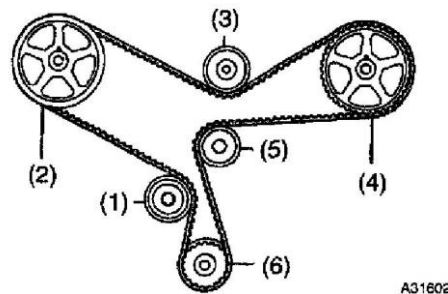

1st	No. 1 idler pulley
2nd	RH camshaft timing pulley
3rd	No. 2 idler pulley
4th	LH camshaft timing pulley
5th	Water pump pulley
6th	Crankshaft timing pulley

- c. Remove the timing belt in this order.

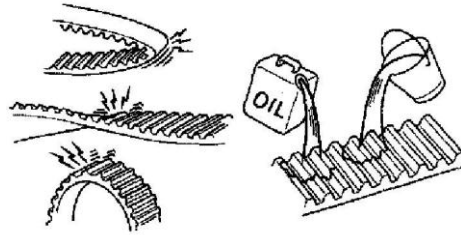

14. INSPECT TIMING BELT

NOTICE:

- Do not bend, twist or turn the timing belt inside out.
- Do not allow the timing belt to come into contact with oil, water or steam.
- Do not utilize timing belt tension when installing or removing the mount bolt of the camshaft timing pulley. If there are any defects, as shown in the illustrations, check these points.

- a. If there is premature parting,
 - Check for proper installation.
 - Check the timing cover gasket for damage and proper installation.
- b. If the belt teeth are cracked or damaged, check to see if either camshaft is locked.
- c. If there is noticeable wear or cracks on the belt face, check to see if there are nicks on the side of the idler pulley lock and water pump.
- d. If there is wear or damage on only one side of the belt, check the belt guide and the alignment of each pulley. e. If there is noticeable wear on the belt teeth, - Check timing cover for damage.
 - Check gasket has been installed correctly.
 - Check for foreign material on the pulley teeth. If necessary, replace the timing belt.

15. INSTALL TIMING BELT

- a. Remove any oil or water on the pulleys, and keep them clean.

NOTICE:

- If adherence of water and/or oil to the timing belt is found, restore the leakage and install a new timing belt.
 - Wipe only the pulleys; do not use any cleansing agent.
- b. Inspect the idler pulleys.
 1. Check that the idler pulley turns smoothly.
 2. Visually check the seal portion of the idler pulley for oil leakage.
 - c. Inspect the water pump.
 1. Turn the pulley, and check that water pump bearing moves smoothly and quietly.
 2. Visually check the drain hole for coolant leakage.
 - d. Temporarily install the crankshaft pulley bolt and washer to the crankshaft.

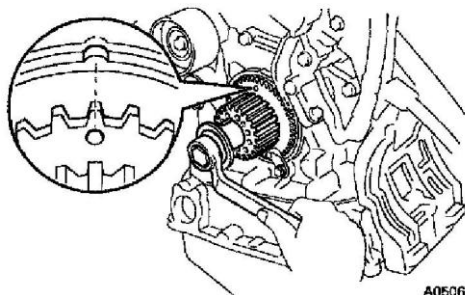

A05062

- e. Turn the crankshaft, and align the timing marks of the crankshaft timing pulley and oil pump body.

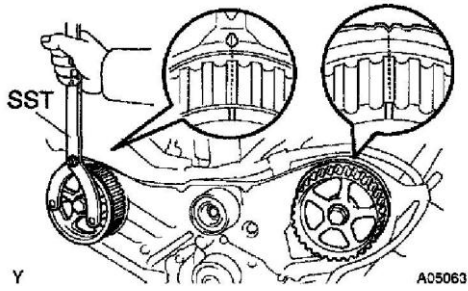

- f. Using SST, turn the camshaft pulley, and align the timing marks of the timing pulley and No. 3 timing belt cover. SST 09960-10010 (09962-01000, 09963-01000)
- g. Face the front mark on the timing belt forward.

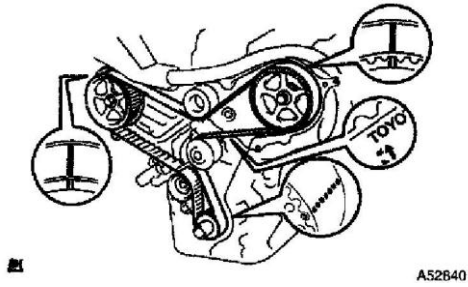

- h. Align the installation mark on the timing belt with the timing mark of the crankshaft timing pulley.
- i. Align the installation marks on the timing belt with the timing marks of the camshaft timing pulleys.

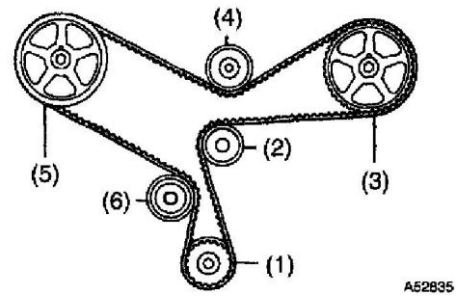

1st	Crankshaft timing pulley
2nd	Water pump pulley
3rd	LH camshaft timing pulley
4th	No. 2 idler pulley
5th	RH camshaft timing pulley
6th	No. 1 idler pulley

- j. Install the timing belt in this order.
16. INSTALL CHAIN TENSIONER ASSY NO. 1
- a. Set the timing belt tensioner upright on the press.

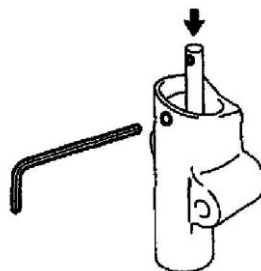

- b. Slowly press in the push rod.

NOTICE: Do not apply pressure more than 9.8 kN (1,000 kgf, 2,205 ft. lbs.) to the rod.

- c. Align the holes of the push rod and housing, pass a 1.5 mm hexagon wrench through the holes to keep the setting position of the push rod. d. Release the press.
- e. Temporarily install the tensioner with the 2 bolts. Alternately tighten the 2 bolts.
Torque: 27 Nm (280 kgf-cm, 20 ft. lbs.)

NOTICE: Be sure to tighten the bolts equally. Installing the tensioner slantingly may cause failure of its proper operation. f. Remove the 1.5 mm hexagon wrench from the tensioner.

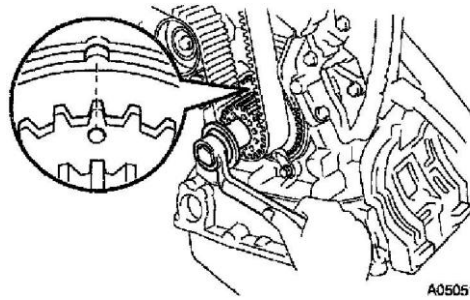

- g. Slowly turn the crankshaft 2 revolutions, and align the timing marks of the crankshaft timing pulley with oil pump body.

NOTICE: Always turn the crankshaft clockwise.

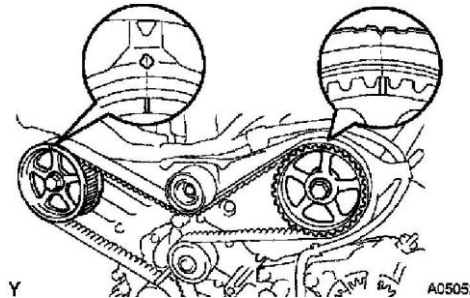

- h. Check the timing marks of the RH and LH timing pulleys with the timing marks of the No. 3 timing belt cover as shown in the illustration.
If the marks do not align, remove the timing belt and reinstall it.
- i. Remove the crankshaft pulley bolt.

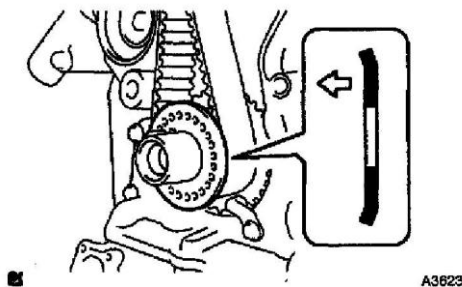

17. INSTALL TIMING BELT GUIDE NO. 2

- a. Install the timing belt guide, facing the cup side toward the engine front.

18. INSTALL TRANSVERSE ENGINE ENGINE MOUNTING BRACKET

- Torque: 28 Nm (286 kgf-cm, 21 ft. lbs.)

19. INSTALL TIMING BELT NO. 2 COVER

- a. Visually check the crack and break in the gasket of the timing belt cover.

HINT: If it is judged that water is entering at the visual check, replace the timing

belt cover. b. Install the timing belt cover.

Torque: 8.5 Nm (87 kgf-cm, 76 inch lbs.)

20. INSTALL TIMING BELT NO. 1 COVER

a. Visually check the crack and break in the gasket of the timing belt cover.

HINT: If it is judged that water is entering at the visual check, replace the timing

belt cover. b. Install the timing belt cover.

Torque: 8.5 Nm (87 kgf-cm, 76 inch lbs.)

c. Install the engine wire protector cover to the timing belt No. 3 cover.

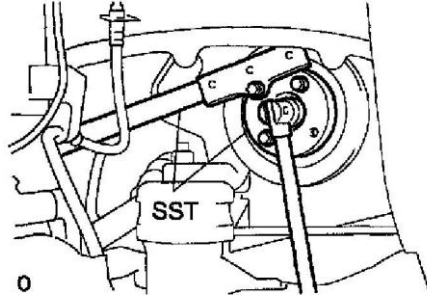

21. INSTALL CRANKSHAFT PULLEY

a. Align the pulley set key with the key groove of the pulley, and slide on the pulley.

b. Using SST, install the pulley bolt.

SST 09213-54015 (91651-60855), 09330-00021

Torque: 215 Nm (2,192 kgf-cm, 159 ft. lbs.)

22. INSTALL GENERATOR BRACKET NO. 2

Torque: 28 Nm (286 kgf-cm, 21 ft. lbs.)

23. INSTALL ENGINE MOUNTING STAY NO. 2 RH

24. INSTALL ENGINE MOVING CONTROL ROD

25. INSTALL VANE PUMP V BELT

26. INSTALL V (COOLER COMPRESSOR TO CRANKSHAFT PULLEY) BELT NO. 1

27. INSPECT DRIVE BELT DEFLECTION AND TENSION

28. INSTALL FRONT WHEEL RH

Torque: 103 Nm (1,050 kgf-cm, 76 ft. lbs.)