

**PREVIOUS
MENU**

INDEX FORD C-6

GO TO PAGE

<i>DESCRIPTION</i>	4
<i>ADJUSTMENTS</i>	5
<i>INSTALLATION</i>	8
<i>DIESEL VACUUM</i>	7
<i>VALVE BODY</i>	18
<i>PUMP</i>	23
<i>TEARDOWN</i>	25
<i>SPECIFICATIONS</i>	31
<i>GENERAL TRANSMISSION SERVICE</i>	33
<i>VACUUM CHECKS AND INFORMATION</i>	37
<i>PRESSURE CHECKS</i>	39
<i>STALL TEST</i>	40
<i>AIR CHECKS</i>	45
<i>TROUBLE SHOOTING</i>	48
<i>TORQUE CONVERTER</i>	64
<i>SHIFT CONTROL LINKAGE</i>	69

**Automatic Transmission Service Group
9200 South Dadeland Blvd.
Suite 720
Miami, FL 33156
(305) 670-4161**



Technical Service Information

INTRODUCTION

FORD C-6

The C-6 transmission was first introduced in September 1965 in the Ford Mercury and Lincoln car lines. This transmission has gone through many changes. So you have to be careful on parts interchanges. The first major change in parts occurred in the 1976 model with both the case and the low reverse piston and the valve body assemblies. With the introduction of diesel engines combined with the C-6 there were changes to both the valve body and the governor. These components do not interchange with the gas models. So be careful. With the introduction in 1989 of the E4OD transmission into trucks some of these components will fit the C-6 transmissions. By 1991 the E4OD forward drum was shared with the C-6. This manual also shows the adjustment of the vacuum regulator for diesel applications.

We thank FORD MOTOR COMPANY
for the information and illustrations that have
made this booklet possible

The information and part numbers contained in this
booklet have been carefully compiled from industry
sources known for their reliability, but ATSG does not
guarantee its accuracy.

ROBERT D. CHERRNAY
TECHNICAL DIRECTOR

WAYNE COLONNA
TECHNICAL SUPERVISOR

PETER LUBAN
TECHNICAL CONSULTANT

GREGORY LIPNICK
TECHNICAL CONSULTANT

DAVID CHALKER
TECHNICAL CONSULTANT

DALE ENGLAND
FIELD SERVICE CONSULTANT

ED KRUSE
TECHNICAL CONSULTANT

JIM DIAL
TECHNICAL CONSULTANT

JERRY GOTT
TECHNICAL CONSULTANT

ARSENIO RIVERA
TECHNICAL CONSULTANT

AUTOMATIC TRANSMISSION SERVICE GROUP
9200 S. DADELAND BLVD. SUITE 720
MIAMI, FLORIDA 33156
(305) 670-4161



Technical Service Information

C6 Automatic Transmission

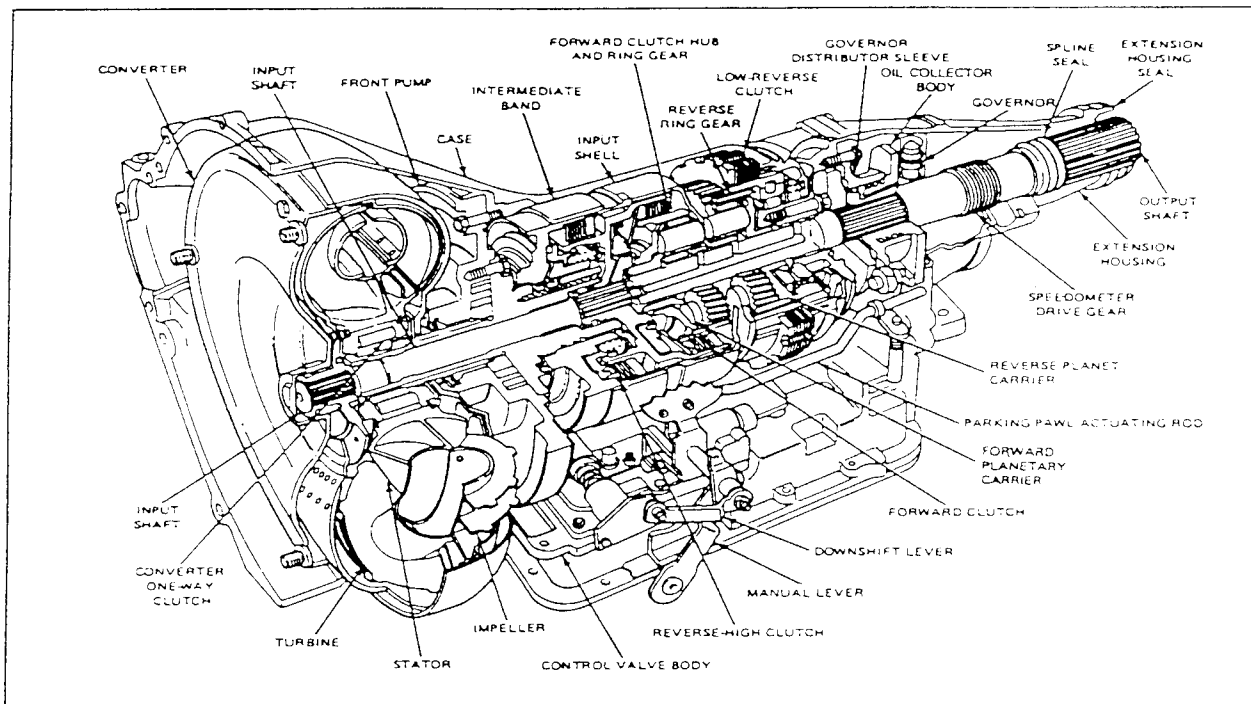

FIG. 1 C6 Automatic Transmission—Sectional

VEHICLE APPLICATION

E-150—E-350, F-150—F-350 (4x2) (4x4) and Bronco Vehicles with C-6 Automatic Transmission.

DESCRIPTION

C6 Transmission

The C6 transmission is a three speed unit capable of providing automatic upshifts and downshifts through the three forward gear ratios. The transmission is also capable of providing manual selection of first and second gears.

Fig. 1 shows the location of the converter, front pump, clutches, gear train and most of the internal parts used in the C6 transmission. The identification tag (Fig. 2), is attached to the intermediate servo lower front cover bolt. The first line on the tag shows the transmission model prefix and suffix. A number appearing after the suffix indicates that the internal parts in the transmission have been changed after initial production start-up. For example, a PGD-BN model transmission that has been changed internally would read PGD-BN1. Both transmissions are basically the same, but some service parts in the PGN-BN transmission are slightly different than the PGD-BN1 transmission. **Therefore, it is important that the codes on the transmission identification tag be checked when ordering parts or making inquiries about the transmission.**

The hydraulic control system schematic is shown in Fig. 3. The converter housing and the fixed splines which engage the splined outside diameter of the low-reverse clutch steel plates, are both cast integrally into the case.

Only one (intermediate) band is used in the C6 transmission. This along with the forward clutch is used to obtain intermediate gear.

Vacuum Regulator Valve (VRV)

Refer to Fig. 4

The Vacuum Regulator Valve (VRV) is used on E-250—E-350 and F-250—F-350 vehicles equipped with 7.3L diesel engines.

On 7.3L diesel engine trucks equipped with a C-6 automatic transmission a Vacuum Regulator Valve (VRV) is incorporated to provide a vacuum signal which is proportional to the throttle position to the vacuum diaphragm of the transmission. The VRV is necessary to provide a vacuum signal to the C-6 transmission because the diesel engine has no vacuum. The VRV is bolted to the fuel injection pump and is actuated by the throttle lever.

A constant vacuum source is supplied to the VRV by an engine driven vacuum pump which also delivers vacuum to other accessories. The VRV regulates an output vacuum signal to the transmission's vacuum diaphragm which is proportional to the throttle position. As the throttle is opened, the regulated vacuum from the VRV drops.

Should a malfunction occur in the VRV, the valve will cause a 0 vacuum signal to be sent to the diaphragm which will cause delayed and harsh shifts to occur.

Anytime delayed or harsh up-shifts are encountered, the performance of the VRV should be checked prior to performing any transmission repairs. Should the VRV be replaced or the fuel injection pump be removed, the VRV must be adjusted to specifications.

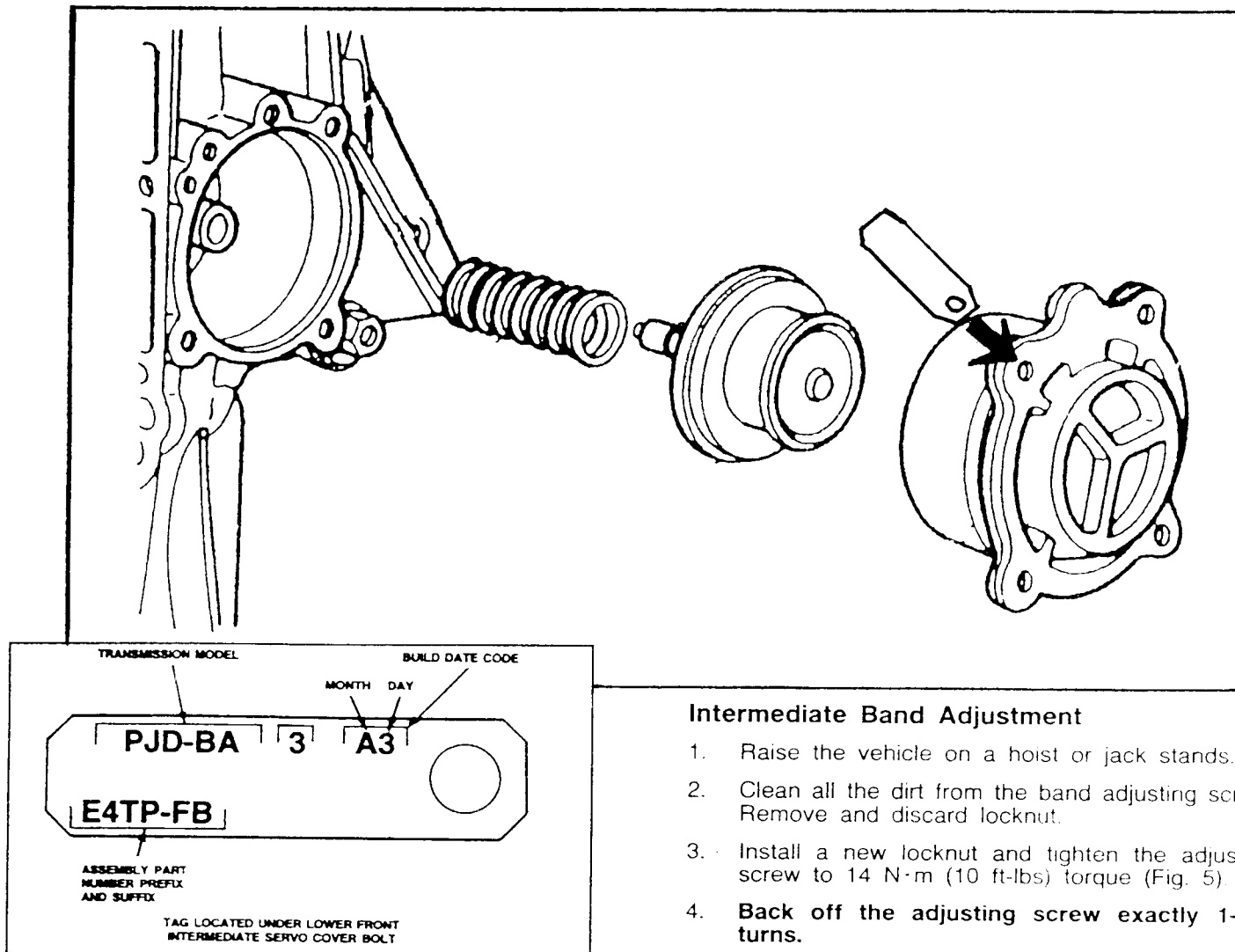

FIG. 2 Identification Tag

ADJUSTMENTS

The only adjustments on the transmission are the intermediate band and the NEUTRAL START switch (and the Vacuum Regulator Valve on vehicles equipped with 7.3L diesel engines).

On vehicles equipped with 7.3L Diesel Engines, the Vacuum Regulator Valve (VRV), which is located on the fuel injector pump must be properly adjusted to regulate vacuum to the transmission vacuum diaphragm.

To prevent damage to the transmission and to assure proper band adjustment, it is essential that the tools and procedures described here are used whenever the band is adjusted.

Intermediate Band Adjustment

1. Raise the vehicle on a hoist or jack stands.
2. Clean all the dirt from the band adjusting screw. Remove and discard locknut.
3. Install a new locknut and tighten the adjusting screw to 14 N·m (10 ft-lbs) torque (Fig. 5)
4. **Back off the adjusting screw exactly 1-1/2 turns.**
5. Hold the adjusting screw from turning and tighten the locknut to 48-61 N·m (35-40 ft-lbs).
6. Lower the vehicle.

Align Neutral Start Switch

1. Apply the parking brake.
2. With the manual linkage properly adjusted, loosen the two switch attaching bolts (Fig. 6).
3. Place the transmission manual lever in NEUTRAL. Rotate the switch and insert the gauge pin (No. 43 drill shank end) into the gauge pin holes of the switch. The gauge pin has to be inserted a full 12.303mm 31/64 inch into the three holes of the switch (Fig. 6).
4. Tighten the two neutral start switch attaching bolts to 6.5-8.0 N·m (55-75 in-lbs). Remove the gauge pin from the switch.
5. Check the operation of the switch. The back up lamps should operate only with the transmission selector lever in **REVERSE**. The vehicle should start only with the transmission selector lever in **PARK** and **NEUTRAL**.

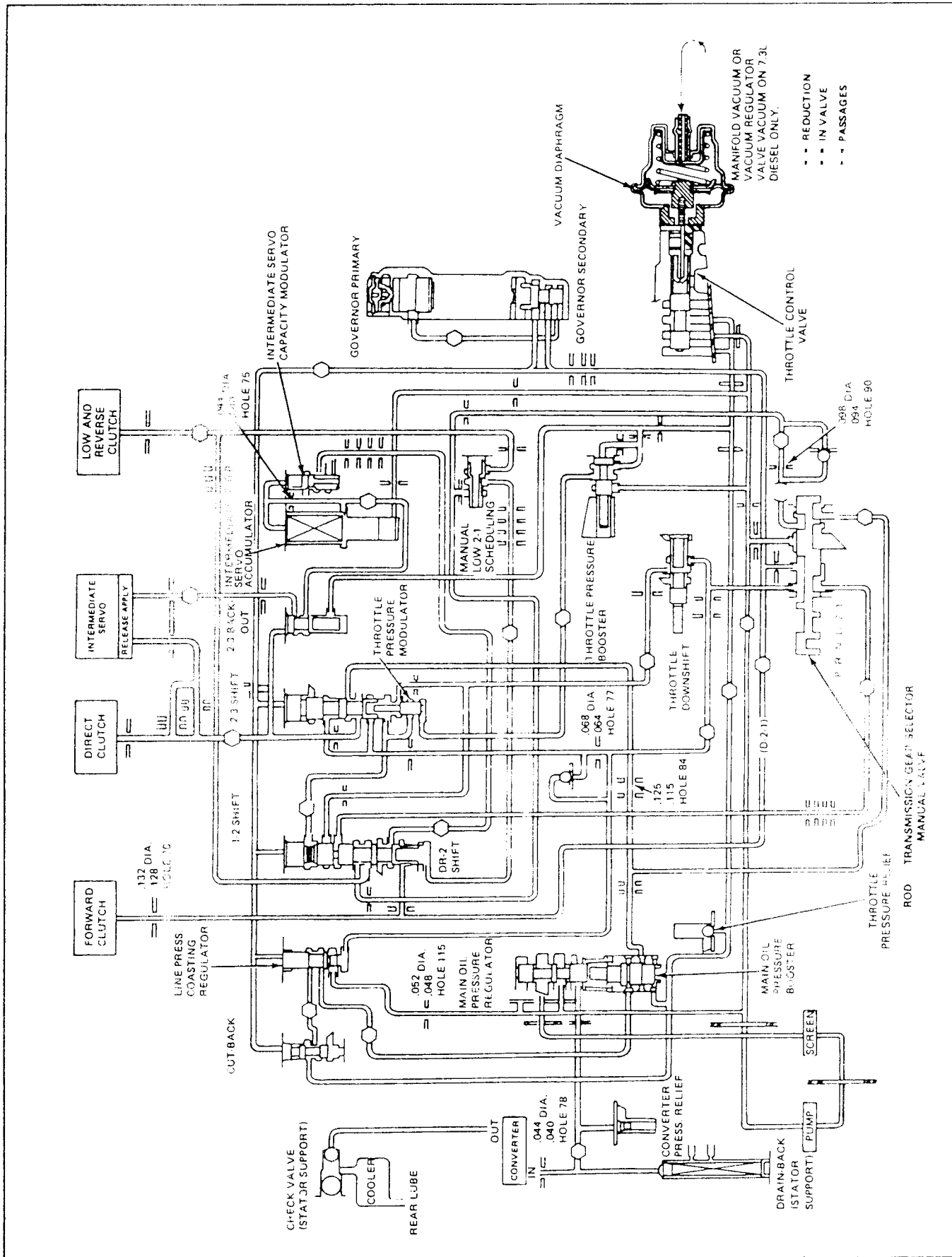

FIG. 3 Hydraulic Control System—C6 Transmission

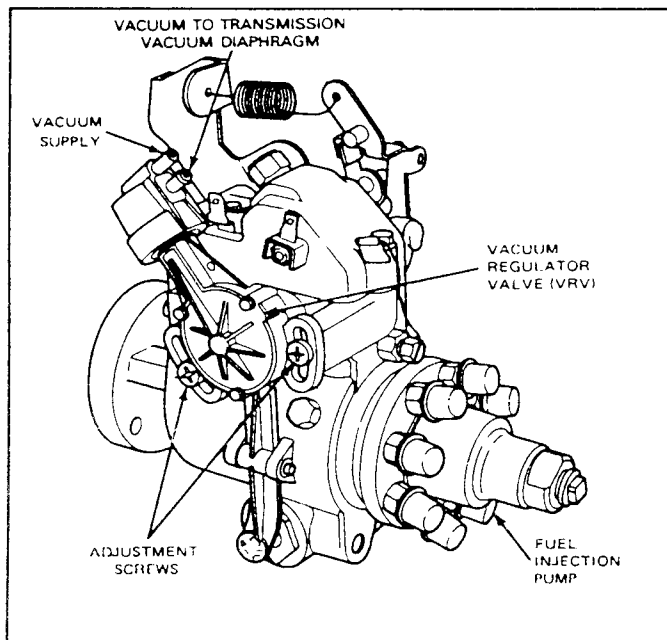

FIG. 4 Vacuum Regulator Valve (VRV)—E-250—E-350, F-250—F-350 with 7.3L Diesel Engine

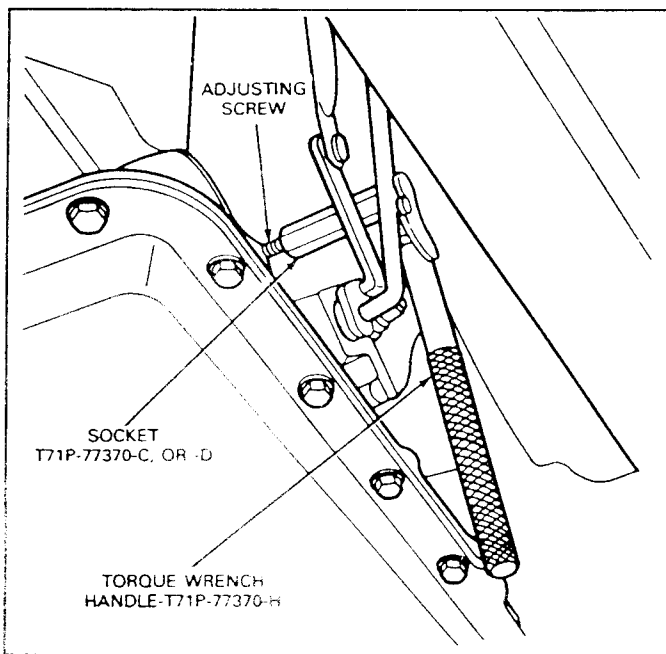

FIG. 5 Adjusting Intermediate Band

Vacuum Regulator Valve (VRV) Operational Check and Adjustment (Vehicles Equipped with 7.3L Diesel Engine only)

Refer to Fig. 4

To check the VRV for proper operation and to adjust, the engine must not be running (TURNED OFF).

1. Disconnect the two port vacuum connector from the VRV located on the left side of the fuel injection pump.
2. Remove the throttle cable from the throttle lever on the right side of the fuel injection pump.

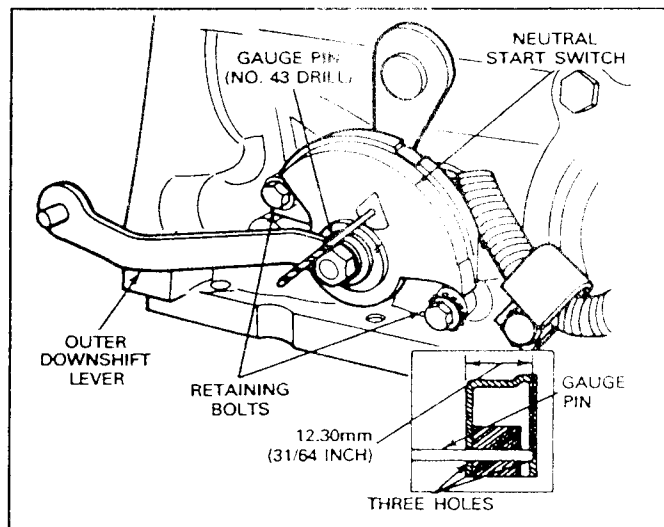

FIG. 6 Neutral Start and Back Up Lamp Switch

3. Remove the throttle return spring. Install the end of the spring over the throttle lever ball stud and the other end over the throttle cable support bracket.
4. Attach a vacuum pump to the upper port of the VRV (vacuum supply side).
5. Attach a vacuum gauge to the lower port of the VRV, labeled TRANS on the VRV.
6. Apply 20 inches minimum of vacuum to the VRV and maintain. **It will be necessary to continually pump the vacuum up as it bleeds off (this is normal). Cycle the throttle lever 5 times from idle to WOT with vacuum applied.** Insert the gauge block, T83T-7B200-AH (0.515 inch), between the pump boss and the throttle wide-open stop (Fig. 7). The throttle return spring (F-Series), as repositioned in step 3 below, will hold the throttle lever stop against the gauge block (Hold throttle lever open on Econoline by other means). **The vacuum gauge attached to the lower port of the VRV should indicate 6-8 inches of vacuum. If the vacuum reading is not correct, adjust the VRV to achieve a reading of 7 inches ($\pm .5$) of vacuum.**
7. To adjust, loosen the two adjustment screws that attach the VRV to the fuel injection pump (Fig. 4). Rotate the VRV until the proper vacuum is obtained. Tighten the two adjusting screws to 8-10.5 N·m (75-90 in-lbs) when the proper vacuum reading is obtained. If the VRV can not be adjusted to obtain the proper vacuum, replace the VRV and repeat procedure from Step 3.
8. Remove the gauge block.
9. Reattach the throttle return spring and throttle cable.
10. Again apply 20 inches of vacuum to the VRV and **while maintaining vacuum, cycle the throttle lever from idle to WOT 5 times.** The vacuum gauge must indicate at least 13 inches (throttle at idle position). If the vacuum gauge indicates less than 13 inches the VRV must be replaced and the new VRV adjusted per the above procedures.
11. After making the check or adjustment, remove the vacuum pump and gauge from the VRV and reattach the vacuum connector.

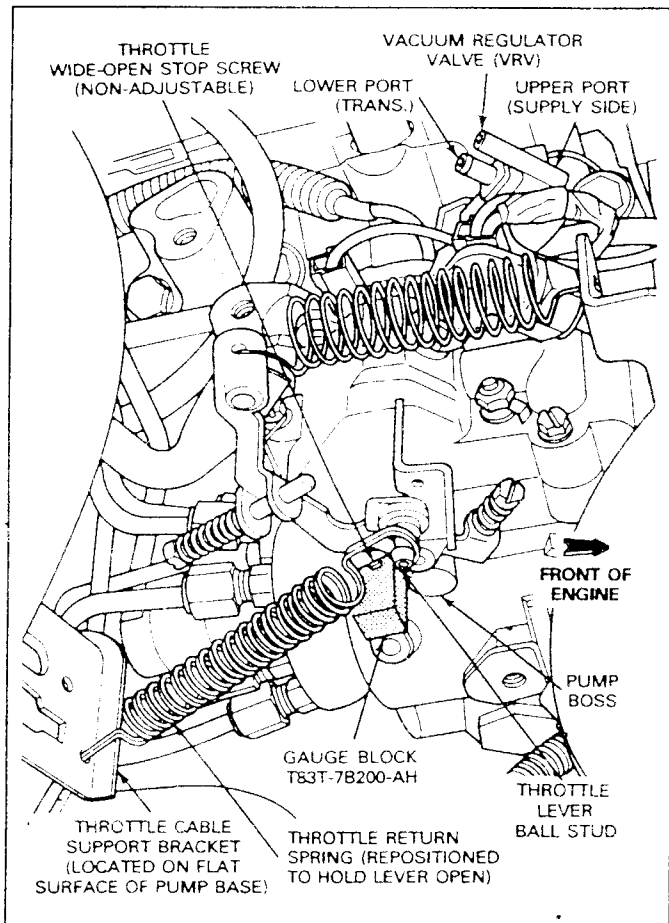

FIG. 7 VRV Gauge Block Installation

12. Start engine and check throttle operation and check transmission shifts.

REMOVAL AND INSTALLATION

Transmission

F-150—F-350 (4x2) (4x4) and Bronco

Removal

1. Drive the vehicle on a hoist, but do not raise at this time. Disconnect the battery negative cable. Disconnect neutral switch wire at the plug connector.
2. Raise the vehicle on a hoist or stands.
3. Place the drain pan under the transmission fluid pan. Starting at the rear of the pan and working toward the front, loosen the attaching bolts and allow the fluid to drain. Finally remove all of the pan attaching bolts except two at the front, to allow the fluid to further drain. With fluid drained, install two bolts on the rear side of the pan to temporarily hold it in place.
4. Remove the converter drain plug access cover from the lower end of the converter housing.
5. Remove the converter-to-flywheel attaching nuts. Place a wrench on the crankshaft pulley attaching bolt to turn the converter to gain access to the bump switch.
6. With the wrench on the crankshaft pulley attaching bolt, turn the converter to gain access to the

converter drain plug. Place a drain pan under the converter to catch the fluid and remove the plug. After the fluid has been drained, re-install the plug.

7. On (4x2) applications disconnect the driveshaft from the rear axle and slide shaft rearward from the transmission. Install a seal installation tool in the extension housing to prevent fluid leakage.
8. Disconnect the speedometer cable from the extension housing.
9. Disconnect the downshift and manual linkage rods or cable controls from the levers at the transmission.
10. Disconnect the oil cooler lines from the transmission.
11. Remove the vacuum hose from the vacuum diaphragm unit. Remove the vacuum line from the retaining clip.
12. Disconnect the cable from the terminal on the starter motor. Remove the three attaching bolts and remove the starter motor.
13. On F-150—F-350 (4x4) and Bronco vehicles, remove the transfer case. Refer to Section 16-80, Borg Warner 13-56 Electronic Shift Transfer Case, 16-81, Borg Warner 13-56 Transfer Case—Manual Shift, or Section 16-86, Borg Warner 1345 Transfer Case.
14. Remove the two engine rear support and insulator assembly-to-attaching bolts (Fig. 8).
15. Remove the two engine rear support and insulator assembly-to-extension housing attaching bolts (Fig. 8).
16. Remove the six bolts securing the No. 2 crossmember to the frame side rails (Fig. 8).
17. Raise the transmission with a transmission jack and remove the crossmember.
18. Secure the transmission to the jack with the safety chain.
19. Remove the converter housing-to-engine attaching bolts.
20. Move the transmission away from the engine. Lower the jack and remove the converter and transmission assembly from under the vehicle.

Installation

1. Tighten the converter drain plug to 11-37 N·m (18-28 ft-lbs).
2. Position the converter on the transmission making sure the converter drive flats are fully engaged in the pump gear.
3. With the converter properly installed, place the transmission on the jack. Secure the transmission to the jack with the chain.
4. Rotate the converter until the studs and drain plug are in alignment with their holes in the flywheel.
5. Move the converter and transmission assembly forward into position, using care not to damage the flywheel and the converter pilot. **The converter must rest squarely against the flywheel. This indicates that the converter pilot is not binding in the engine crankshaft. Do not allow converter drive flats to disengage from pump gear.**

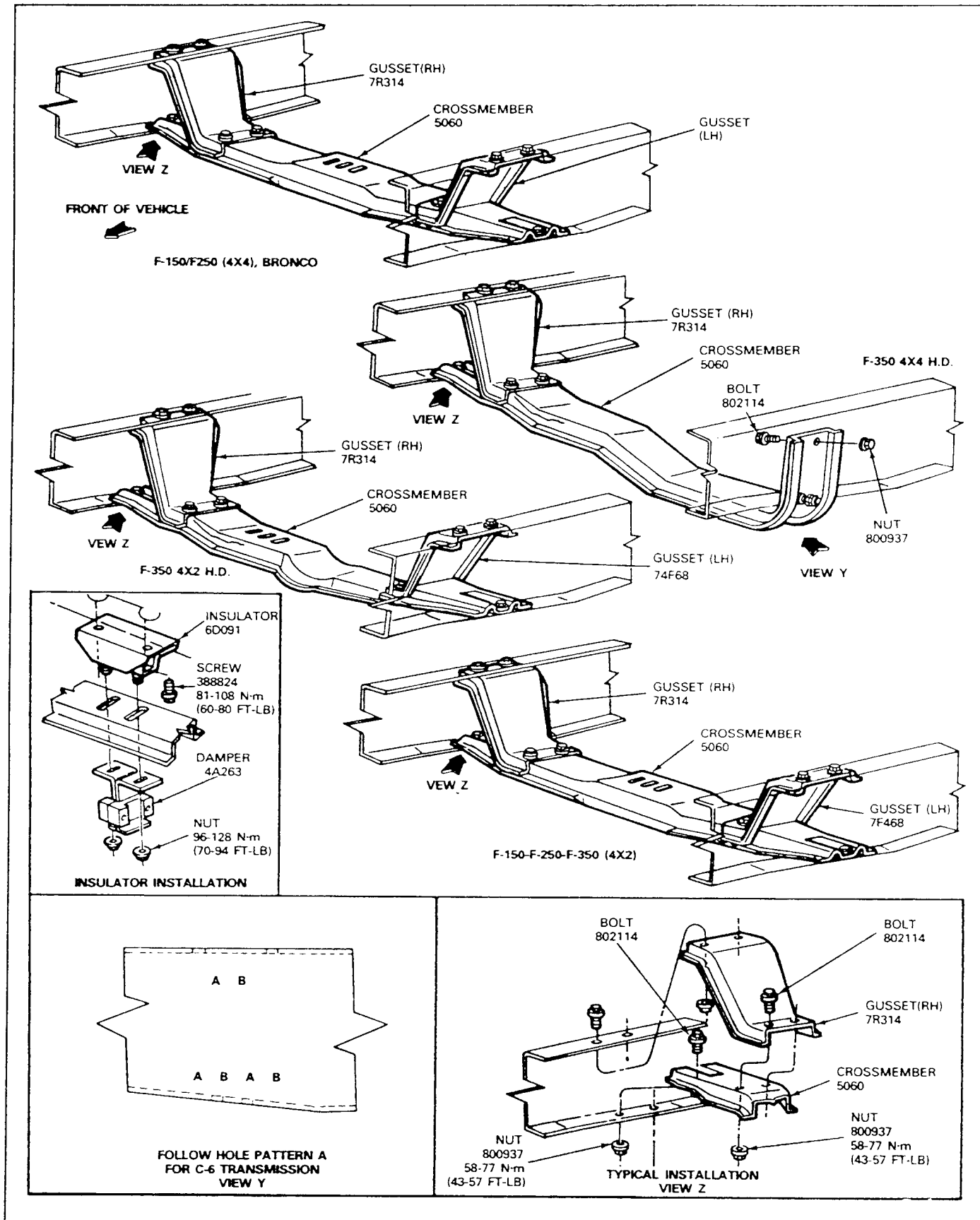

FIG. 8 Crossmember Installation F-150—F-350 (4x2) (4x4)



Technical Service Information

6. Install and tighten the converter housing-to-engine attaching bolts to 55-67 N·m (40-50 ft-lbs) on gasoline engines and 67-87 N·m (50-65 ft-lbs) on diesel engines.
7. Remove the transmission jack safety chain from around the transmission.
8. Position the No. 2 crossmember to the frame side rails. Install and tighten the attaching bolts to specifications as listed at the end of this Section.
9. Install transfer case on F-150—F-250 (4x4) and Bronco. Refer to Section 16-80, Borg Warner 13-56 Electronic Shift Transfer Case, 16-81, Borg Warner 13-56 Transfer Case—Manual Shift, or Section 16-86, Borg Warner 1345 Transfer Case.
10. Position the engine rear support and insulator assembly above the crossmember. Install the rear support and insulator assembly-to-extension housing mounting bolts and tighten the bolts to specifications as listed at the end of this Section.
11. Lower the transmission and remove the jack.
12. Secure the engine rear support and insulator assembly to the crossmember with the attaching bolts and tighten them to specifications as listed at the end of this Section.
13. Connect the vacuum line to the vacuum diaphragm making sure that the line is in the retaining clip.
14. Connect the oil cooler lines to the transmission.
15. Connect the downshift and manual linkage rods or cable controls to their respective levers on the transmission. Refer to Section 17-02 Shift Control Linkage, Removal and Installation.
16. Connect the speedometer cable to the extension housing.
17. Secure the starter motor in place with the attaching bolts. Connect the cable to the terminal on the starter.
18. Install a new O-ring on the lower end of the transmission filler tube and insert the tube in the case.
19. Secure the converter-to-flywheel attaching nuts and tighten them to 28-40 N·m (20-30 ft-lbs).
20. Install the converter housing access cover and secure it with the attaching bolts.
21. Connect the driveshaft.
22. Fill the transmission to the proper level with the specified fluid.
23. Adjust the shift linkage as required. Refer to Section 17-02, Shift Control Linkage.
24. Connect neutral switch wire to plug connector.
25. Connect the battery negative cable.
4. If the vehicle is equipped with a V-8 engine, remove the flexhose from the air cleaner heat tube.
5. Remove the bolt securing the filler tube to the engine.
6. Raise the vehicle on a hoist.
7. Place the drain pan under the transmission fluid pan. Starting at the rear of the pan and working toward the front, loosen the attaching bolts and allow the fluid to drain. Finally remove all of the pan attaching bolts except two at the front, to allow the fluid to further drain. With fluid drained, install two bolts on the rear side of the pan to temporarily hold it in place.
8. Remove the converter drain plug access cover from the lower end of the converter housing.
9. Remove the converter-to-flywheel attaching nuts. Place a wrench on the crankshaft pulley attaching bolt to turn the converter to gain access to the nuts.
10. With the wrench on the crankshaft pulley attaching bolt, turn the converter to gain access to the converter drain plug. Place a drain pan under the converter to catch the fluid. Then, remove the plug. With fluid drained, re-install the plug.
11. Disconnect the driveshaft.
12. Remove fluid filler tube.
13. Disconnect the starter cable at the starter. Remove the starter-to-converter housing attaching bolts and remove the starter.
14. Position an appropriate engine support bar to the frame and engine oil pan flanges.
15. Disconnect the cooler lines from the transmission. Disconnect the vacuum line from the vacuum diaphragm unit. Remove the vacuum line from the retaining clip at the transmission.
16. Remove the speedometer driven gear from the extension housing.
17. Disconnect the manual and downshift linkage rods or cable controls from the transmission control levers.
18. Position a transmission jack to support the transmission. Install the safety chain to hold the transmission.
19. Remove the bolts and nuts securing the rear support and insulator assembly to the crossmember. Remove the six bolts retaining the crossmember to the side rails and remove the two support gussets. Raise the transmission with the jack and remove the crossmember (Fig. 9).
20. Remove the converter housing-to-engine attaching bolts. Lower the jack and remove the converter and transmission assembly from under the vehicle.
21. Remove the converter and mount the transmission in a holding fixture.

Transmission

E-150—E-350

Removal

1. Disconnect the battery negative cable.
2. Working from inside the vehicle, remove the engine compartment cover.
3. Disconnect the neutral start switch wires at the plug connector.

Installation

1. Tighten the converter drain plug to specification as listed at the end of this Section.
2. Position the converter on the transmission making sure the converter drive flats are fully engaged in the pump gear.



Technical Service Information

3. With the converter properly installed, place the transmission on the jack. Secure the transmission to the jack with the safety chain.
4. Rotate the converter until the studs and drain plug are in alignment with their holes in the flywheel.
5. Move the converter and transmission assembly forward into position, using care not to damage the flywheel and the converter pilot.

The converter must rest squarely against the flywheel. This indicates that the converter pilot is not binding in the engine crankshaft. Do not allow converter drive flats to disengage from pump gear.

6. Install the converter housing-to-engine attaching bolts. Tighten the bolts to 55-67 N·m (40-50 ft-lbs) on gasoline engines and 67-87 N·m (50-65 ft-lbs) on diesel engines. Install the converter-to-flywheel attaching nuts. Tighten the nuts to 28-40 N·m (20-30 ft-lbs).
7. Install the crossmember. Install the rear support and insulator assembly-to-crossmember attaching bolts and nuts. Tighten the bolts to specifications as listed at the end of this Section.
8. Remove the safety chain and remove the jack from under the vehicle. Remove the engine support bar.
9. Install a new O-ring on the lower end of the transmission filler tube and insert the tube and dipstick in the case.
10. Connect the vacuum line to the vacuum diaphragm making sure the line is secured in the retaining clip.
11. Connect the cooler lines to the transmission.
12. Install the speedometer driven gear into the extension housing. Tighten the attaching bolt to specifications as listed at the end of this Section.
13. Connect the transmission linkage rods to the transmission control levers. When making transmission control attachments new retaining ring and grommet should always be used (see Removal and Installation in Section 17-02, Shift Control Linkage). Note precautions necessary to prevent grommet damage. Attach the shift rod to the steering column shift lever (refer to Fig. 2, Section 17-02, Shift Control Linkage). Align the flats of the adjusting stud with the flats of the rod slot and insert the stud through the rod. Assemble the adjusting stud nut and washer to a loose fit. Perform a linkage adjustment as outlined in Section 17-02, Shift Control Linkage.
14. Install the converter housing access cover and tighten the attaching bolts to 17-21 N·m (12-16 ft-lbs).
15. Position the starter into the converter housing and install the attaching bolts. Tighten the bolts to 55-67 N·m (40-50 ft-lbs) on gasoline engines and 67-87 N·m (50-65 ft-lbs) on diesel engines. Install the starter cable.
16. Install the driveshaft.
17. Lower the vehicle.
18. On V-8 engines, install the flex hose to the air cleaner heat tube. Install the bolt that retains the filler tube to the cylinder block.
19. Connect the neutral start switch wires at the plug connector.

20. Fill the transmission to the proper level with the specified fluid.
21. Raise the vehicle and check for transmission fluid leakage. Make sure the transmission fluid pan is securely attached. Lower the vehicle and adjust the downshift and manual linkage. Refer to Section 17-02, Shift Control Linkage.
22. Connect the battery negative cable.
23. Install the engine compartment cover.

Control Valve Body

Refer to Fig. 17.

Removal

1. Raise the vehicle on a hoist or jack stands.
2. Place a drain pan under the transmission and loosen the bolts holding the transmission pan to drain the fluid from the transmission.
3. Remove the transmission pan attaching bolts from both sides and the rear to allow the fluid to drain further. Finally, remove the remainder of the attaching bolts. Remove the pan and gasket. Remove and discard the nylon shipping plug from the pan. This plug is used to retain transmission fluid within the transmission during shipment and should be discarded when the oil pan is removed.
4. Remove the valve body attaching bolts and remove the valve body from the case.

Installation

1. Position the valve body to the case making sure that the selector and downshift levers are engaged. Install and tighten the attaching bolts to 11-14 N·m (95-125 in.-lbs).
2. Clean the transmission pan and gasket surfaces thoroughly.
3. Using a new pan gasket, install attaching bolts securing the pan to the transmission case. Tighten the attaching bolts to 10.5-17 N·m (8-12 ft-lbs).
4. Lower the vehicle and fill the transmission to the correct level with the specified fluid.

Intermediate Servo

(Refer to Fig. 10).

Removal

1. Raise the vehicle on a hoist or stands.
2. Remove the bolts that secure the engine rear support to the transmission extension rear support and insulator assembly to the crossmember.
3. Remove the two crossmember-to-frame attaching bolts, and the bolts attaching the gussets to the crossmember if so equipped.
4. Raise the transmission high enough to remove the weight from the crossmember and remove the crossmember.
5. Disconnect the muffler inlet pipe from the exhaust manifolds and allow the pipe to hang.
6. Place a drain pan under the servo. Remove the bolts that attach the servo cover to the transmission case.
7. Remove the cover, piston, spring and gasket from the case, screwing the band adjusting screw inward as the piston is removed. This places

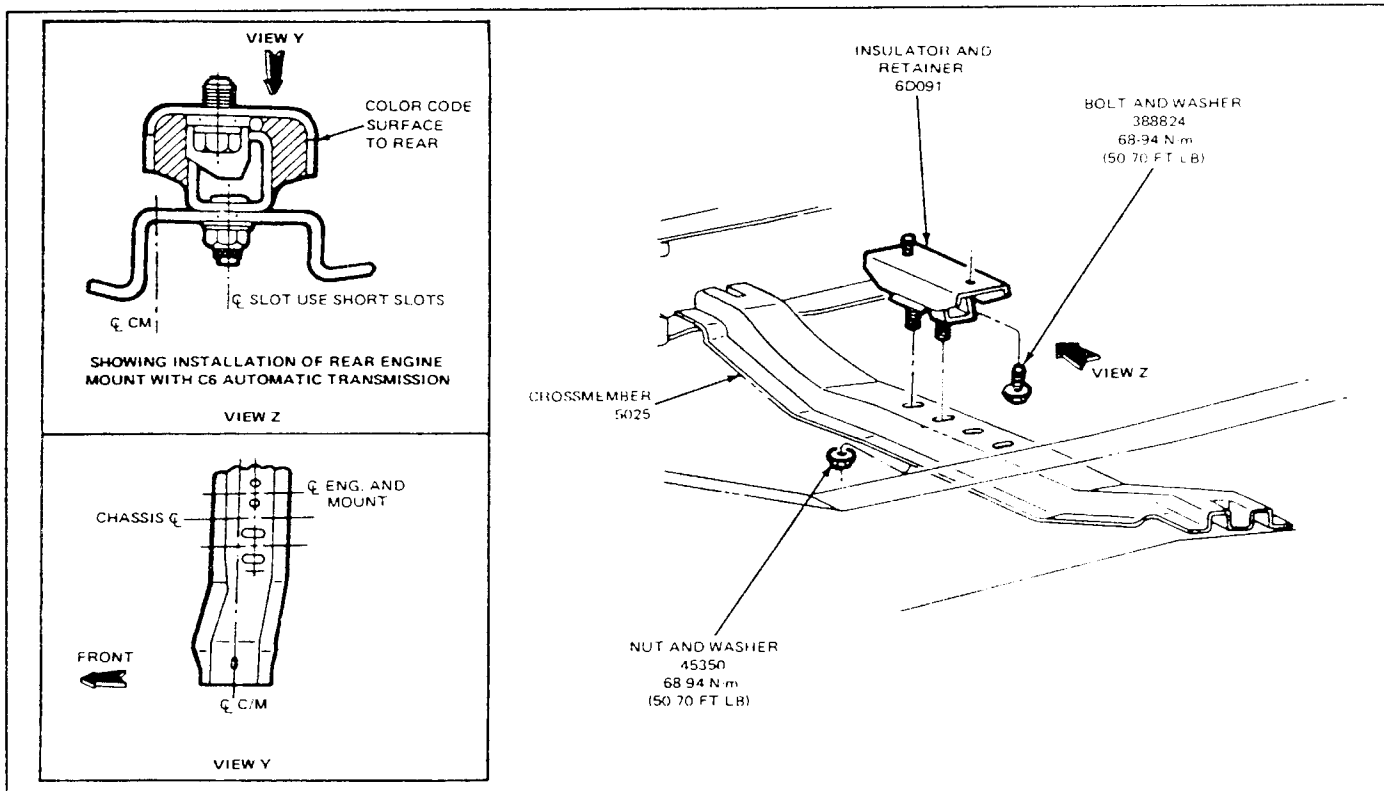

FIG. 9 Crossmember Installation—E-150—E-350

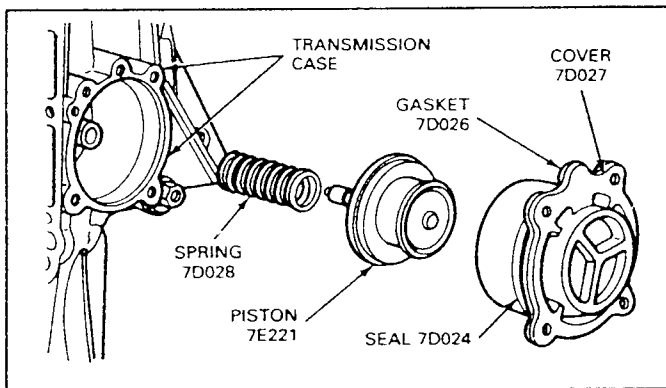

FIG. 10 Intermediate Servo Disassembled—Typical

enough tension on the band to keep the struts properly engaged in the band end notches while the piston is removed.

8. Apply air pressure to the port in the servo cover to remove the piston and rod.
9. Replace the complete piston and rod assembly if the piston or piston sealing lips are damaged, (Fig. 10).
10. Remove the seal from the cover.

Installation

1. Dip the new seal in transmission fluid.
2. Install a new seal on the cover.
3. Coat new gasket with petroleum jelly, and position on the servo cover.
4. Dip the piston in transmission fluid and install it in the cover.

5. Position the servo spring on the piston rod.
6. Insert the servo piston and cover in the case and secure the cover to the case with the attaching bolts, taking care to back off the band adjusting screw as the cover bolts are tightened 19-27 N·m (14-20 ft-lbs). **Make sure that the service identification tag is in place.**
7. Connect the muffler inlet pipe to the exhaust manifolds.
8. Raise the transmission high enough to install the crossmember. Secure the crossmember to the rear support with the attaching bolts. Lower the transmission as required to install the crossmember to frame and gussets attaching bolts. Tighten the attaching bolts to specifications as listed at the end of this Section.
9. Remove the jack from the transmission. Adjust the band as detailed in the Adjustment portion of this Section.
10. Lower the vehicle and replenish the fluid as required. Refer to Section 17-01 General Automatic Transmission Service.

Extension Housing Bushing and Rear Seal

E-150—E-350, F-150—F-350 (4x2)

Removal

1. Raise the vehicle and disconnect the driveshaft at the transmission.
2. When only the rear seal needs replacing, carefully remove it with a tapered chisel or the Tools, T50T-100-A and TOOL-1175-AC, shown in Fig. 11. Remove the bushing using Tool T77L-7697-D or equivalent as shown in Fig. 12. **Use the bushing**

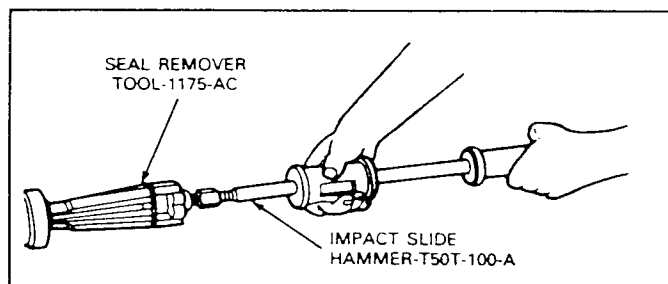

FIG. 11 Removing Extension Housing Seal

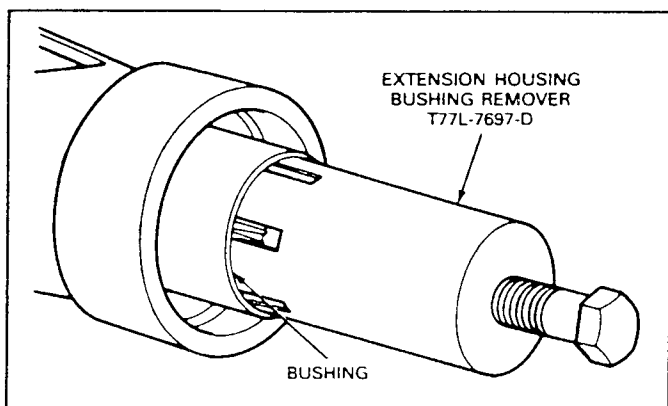

FIG. 12 Removing Extension Housing Bushing

remove carefully so that the spline seal is not damaged.

Installation

1. When installing a new bushing use the special Tool T77L-7697-C shown in Fig. 13.
2. Before installing a new seal, inspect the sealing surface of the universal joint yoke for scores. If scores are found, replace the yoke.
3. Inspect the counterbore of the housing for burrs. Remove burrs with crocus cloth.
4. Install the seal into the housing with Tool T61L-7657-B shown in Fig. 14, or an equivalent. The seal should be firmly seated in the bore. Coat the inside diameter of the end of the seal with Long-Life Lubricant, C1AZ-19590-BA (ESA-M1C75-B) or an equivalent lubricant.
5. Coat the front universal joint spline with Long-Life Lubricant C1AZ-19590-BA (ESA-M1C75-B) or an equivalent lubricant and install the driveshaft.

Extension Housing

Removal

1. Raise the vehicle on a hoist or stands.
2. Disconnect the driveshaft from the rear axle flange and remove it from the transmission. On 4x4 vehicles, remove the transfer case. Refer to Section 16-80, Borg Warner 13-56 Electronic Shift Transfer Case, 16-81 Borg Warner 13-56 Transfer Case-Manual Shift, or 16-86, Borg Warner 1345 Transfer Case.
3. Disconnect the speedometer cable from the extension housing.
4. Remove the engine rear support and insulator assembly-to-extension housing attaching bolts.

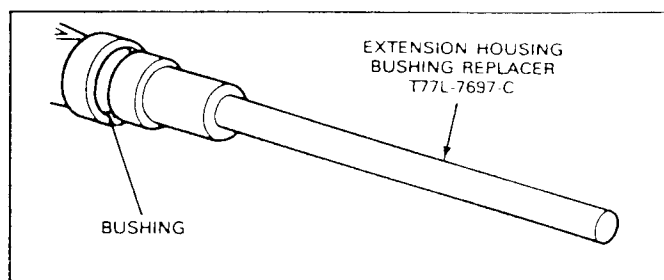

FIG. 13 Installing Extension Housing Bushing

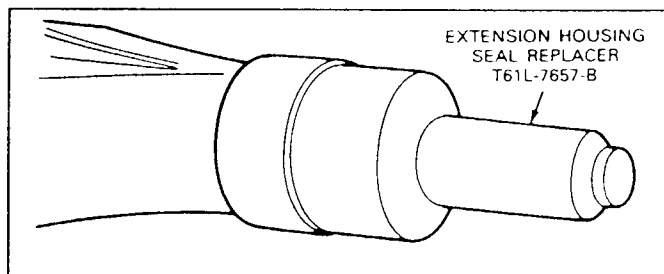

FIG. 14 Installing Extension Housing Seal

5. Place a jack under the transmission and raise it just enough to remove the weight from the engine rear support.
6. Remove the bolts that secure the engine rear support to the crossmember and remove the support.
7. Place a drain pan under the rear of the transmission case.
8. Lower the transmission and remove the extension housing attaching bolts. Slide the extension housing off the output shaft and allow the fluid to drain.

Installation

1. Clean the mounting surface on the transmission case and on the extension housing. Position a new gasket on the transmission case.
2. Hold the extension housing in place and secure it with the attaching bolts. Tighten bolts to 34-47 N·m (25-35 ft-lbs).
3. Raise the transmission high enough to position the engine rear support on the crossmember.
4. Secure the support to the crossmember with the attaching bolts and nuts. Tighten the bolts to specification as listed at the end of this Section.
5. Lower the transmission and remove the jack. Install the engine rear support-to-extension housing attaching bolts. Tighten bolts to specification as listed at the end of this Section. On 4x4 vehicles, install the transfer case. Refer to Section 16-80, 16-81 or 16-86.
6. Secure the speedometer cable to the extension housing with the attaching bolt.
7. Install the driveshaft and lower the vehicle to the floor.
8. Fill the transmission to the correct level with the specified fluid.

Governor

Removal

1. Remove the extension housing as outlined in this Section.
2. Remove the four governor body-to-oil-collector attaching bolts (Fig. 15).
3. Remove the governor from the collector body flange.
4. Refer to the Disassembly and Assembly Section of this Section for Governor repair operations.

Installation

1. Secure the governor (Fig. 15) to the oil collector flange with the attaching bolts. Tighten the bolts to 10.5-13.5 N·m (90-120 in.-lbs).
2. Re-install the extension housing as outlined in this Section.

DISASSEMBLY AND ASSEMBLY

Transmission

Refer to Fig. 38.

Before removing any of the subassemblies, thoroughly clean the outside of the transmission to prevent dirt from entering the mechanical parts.

During the repair of the subassemblies, certain general instructions which apply to all units of the transmission must be followed. Following these instructions will avoid unnecessary repetition.

Handle all transmission parts carefully to avoid nicking or burring the bearing or mating surfaces. Lubricate all internal parts of the transmission with clean automatic transmission fluid before assembly.

Do not use any other lubricants except on gaskets and thrust washers. These may be coated with petroleum jelly to facilitate assembly. Always use new gaskets and seals when assembling a transmission. Refer to Section 17-01, General Automatic

Transmission Service for Cleaning and Inspection Procedures.

Tighten all bolts and screws to the recommended torque as outlined in specifications at end of this Section.

Disassembly

1. Remove the converter, and mount the transmission in holding fixture Rotunda Model 014-00106 or equivalent, (Fig. 16).

NOTE: If equipped, remove and discard the nylon shipping plug from the pan. This plug is used to retain transmission fluid within the transmission during shipping. It should be discarded when the oil pan is removed.

2. Remove the 17 fluid pan attaching bolts. Remove the pan and gasket.
3. Remove the eight valve body attaching bolts. Lift the valve body (Fig. 17) from the transmission case.

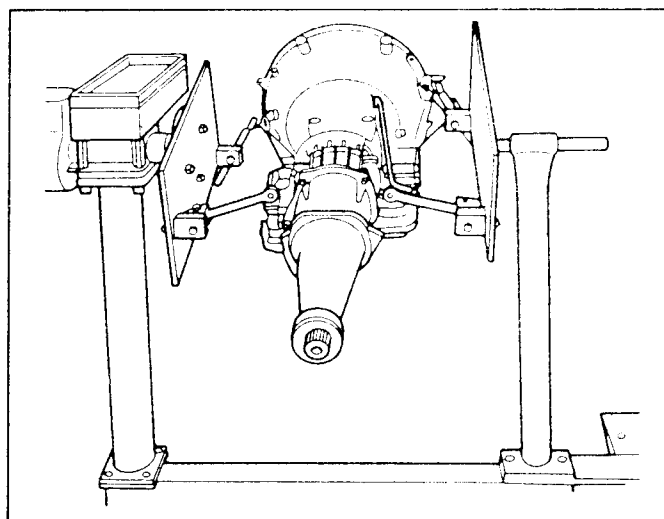

FIG. 16 Transmission Mounted in Holding Fixture

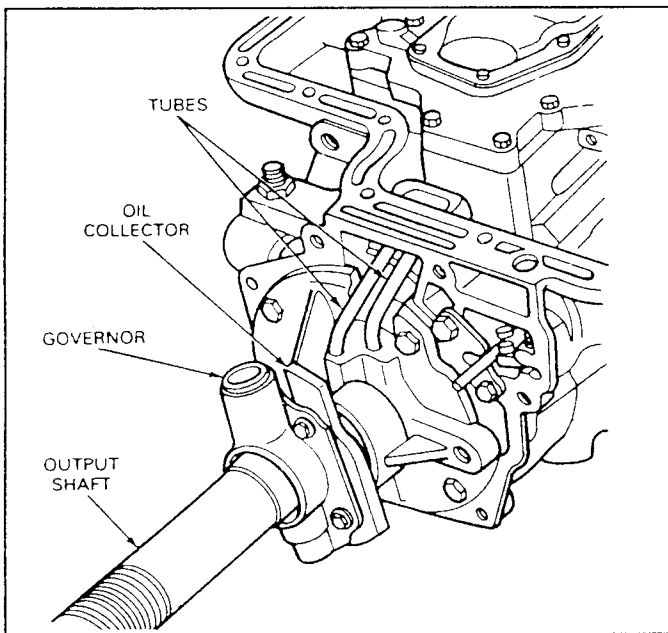

FIG. 15 Governor Installed

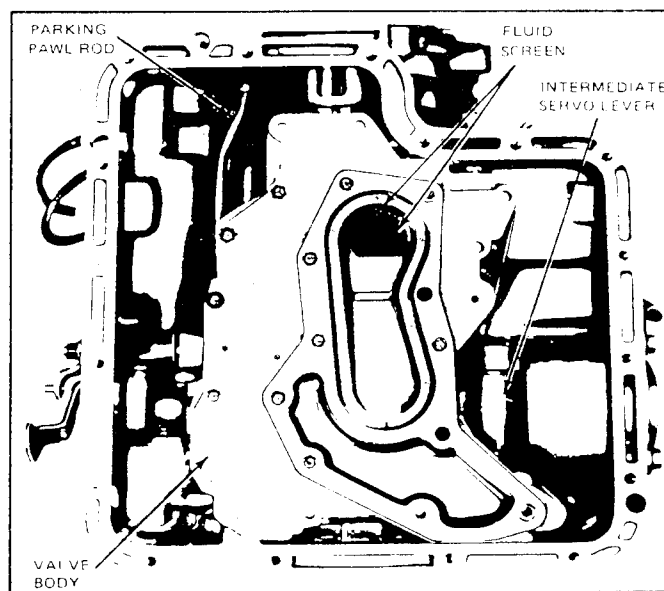

FIG. 17 Transmission With Pan Removed

4. Attach a dial indicator TOOL-4201-C or equivalent to the front pump as shown in Fig. 18. Install Extension Housing Seal Replacer T61L-7657-B in the extension housing to center the output shaft.
5. Pry the gear train to the rear of the case and at the same time, press the input shaft inward until it bottoms, (Fig. 18). Set the dial indicator to read zero.
6. Pry the gear train forward, (Fig. 18), and note the amount of gear train end play on the dial indicator. Record the end play to facilitate assembling the transmission. Remove the dial indicator from the pump and the tool from the extension housing.

7. Remove the vacuum diaphragm, valve rod and the throttle valve from the bore in the rear of the case. Slip the input shaft out of the front pump.
8. Remove the front pump attaching bolts. Pry the gear train forward as shown in Fig. 19 to remove the pump.
9. Loosen the band adjustment screw and remove the two struts.
10. Rotate the band 90 degrees counterclockwise to align the ends with the slot in the case (Fig. 20). Slide the band off the reverse-high clutch drum.
11. Remove the forward part of the gear train as an assembly as shown in Fig. 21.
12. Remove the bolts that attach the servo cover to the transmission case.
13. Remove the cover, piston, spring and gasket from the case.

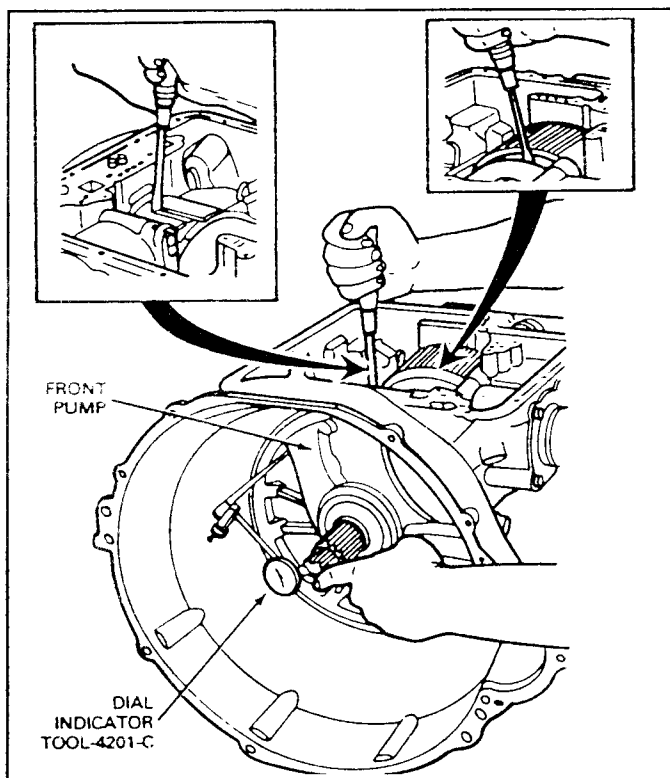

FIG. 18 Checking Gear Train End Play

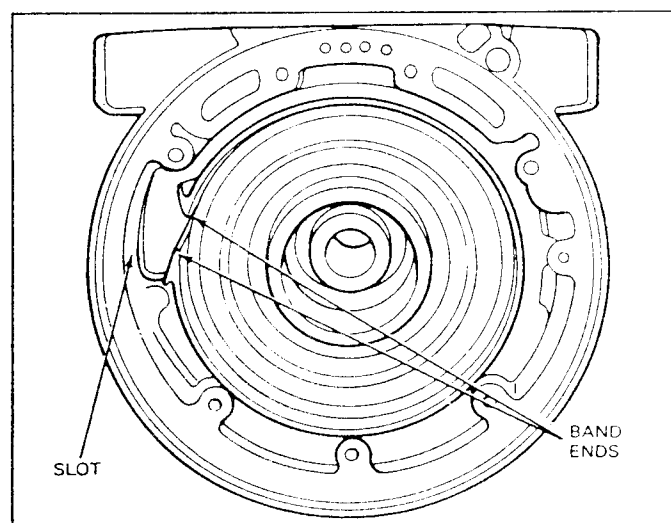

FIG. 20 Removing or Installing Band

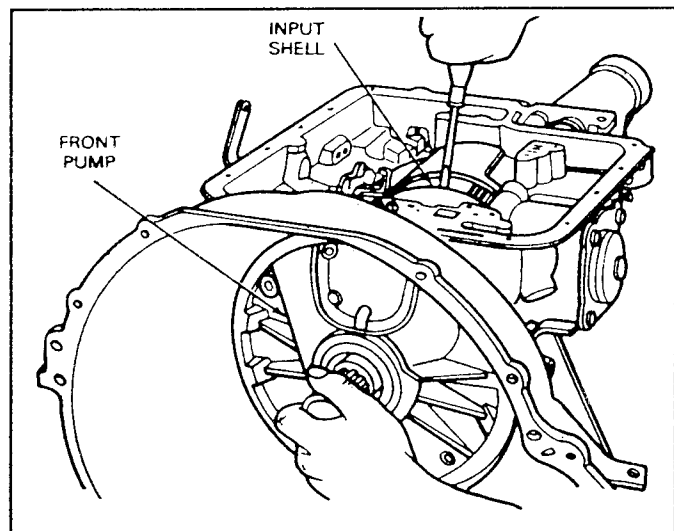

FIG. 19 Removing Front Pump

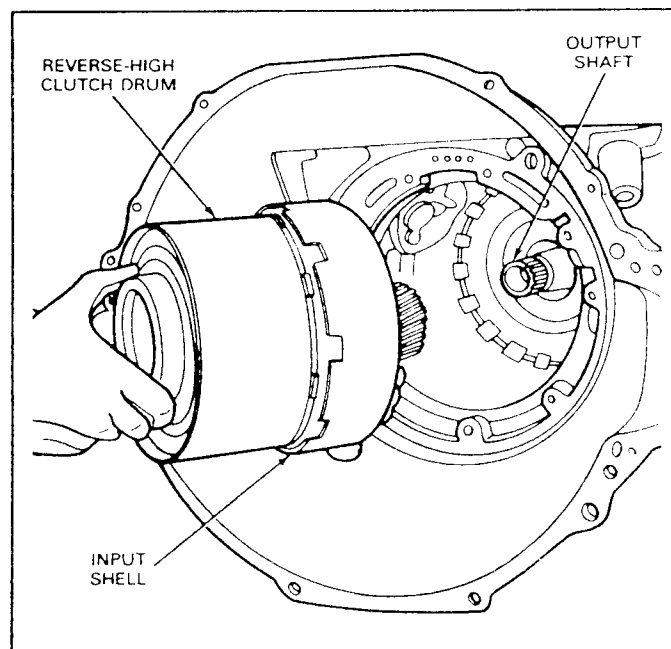

FIG. 21 Removing or Installing Forward Part of Gear Train

14. Remove the large snap ring that secures the reverse planet carrier in the low-reverse clutch hub. Lift the thrust washers and planet carrier from the drum.
15. Remove the snap ring, (Fig. 22), that secures the reverse ring gear and hub on the output shaft. Slide the ring gear and hub off the shaft. Remove the thrust washer.
16. Rotate the low-reverse clutch hub in a clockwise direction and at the same time, withdraw it from the case.
17. Remove the reverse clutch snap ring from the case, then remove the clutch discs, plates and pressure plate from the case.
18. Remove the extension housing attaching bolts from the case. Remove the extension housing and gasket.
19. Slide the output shaft (with governor and oil collector) assembly from the transmission case.
20. Remove the distributor sleeve attaching bolts and remove the sleeve, parking pawl gear and the thrust washer.

If the thrust washer is staked in place, use a sharp chisel and cut off the metal from behind the thrust washer. Be sure to clean the rear of the case with air pressure or a suitable solvent to remove any metal particles.

21. Remove the one-way clutch inner race attaching bolts from the rear of the case. Remove the inner race and reverse clutch spring retainer assembly from inside of the case.
22. Remove the low-reverse clutch piston from the case using TOOL-7000-DE or equivalent as shown in Fig. 23.

Assembly

1. Place the transmission case in a holding fixture.
2. Tap the low-reverse piston into place in the case with a clean rubber hammer.
3. Install the low-reverse clutch spring retainer assembly and retainer assembly in the clutch piston.

4. Hold the one-way clutch inner race in position and install the attaching bolts. Tighten bolts to 25-33 N·m (18-25 ft-lbs).
5. Place the transmission case on the bench with the front end facing downward.
6. Position the parking gear thrust washer and the gear on the case (Fig. 31). **Do not re-stake the thrust washer.**
7. Position the collector and tubes in place on the rear of the case. Install the attaching bolts and tighten to 17-21 N·m (12-16 ft-lbs).
8. Install the output shaft, and governor as an assembly.
9. Place a new gasket on the rear of the transmission case. Position the extension housing on the case and install the attaching bolts. Tighten the attaching bolts to 34-47 N·m (25-35 ft-lbs).
10. Place the transmission case in the holding fixture.
11. Coat new gasket with petroleum jelly and position on the servo cover.
12. Position the servo spring on the piston rod.
13. Insert the servo piston rod in the case. Install the servo cover with the attaching bolts, making sure that the identification tag is in place. Tighten the attaching bolts to 19-27 N·m (14-20 ft-lbs).
14. Align the low-reverse clutch hub and one-way clutch with the inner race at the rear of the case. Rotate the low-reverse clutch hub clockwise while applying pressure to seat it on the inner race.
15. Install the low-reverse clutch plates, starting with the wave plate next to the piston and following with steel and friction plates alternately. Retain them with petroleum jelly. If new composition plates are being used, soak them in clean transmission fluid, Motorcraft MERCON® Multi-Purpose Automatic Transmission Fluid XT-2QDX or DDX (ESP-M2C166-H), or equivalent for fifteen minutes before installation. Install the pressure plate and the snap ring. Test the operation of the low-reverse clutch by applying air pressure at the clutch pressure apply hole in the case.

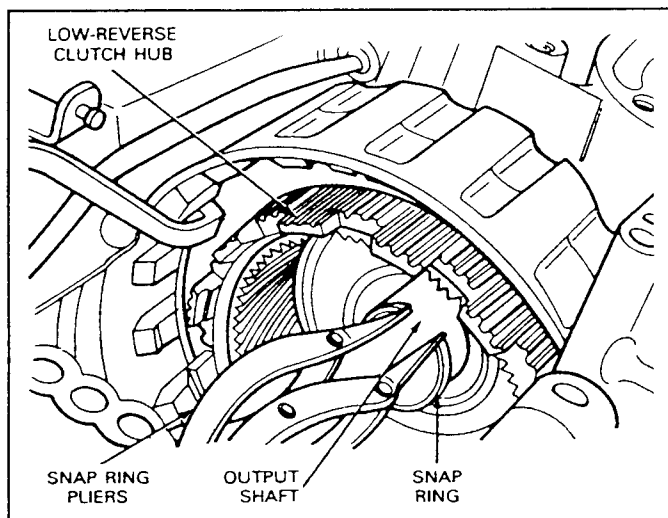

FIG. 22 Removing or Installing Reverse Ring Gear Hub, Snap Ring

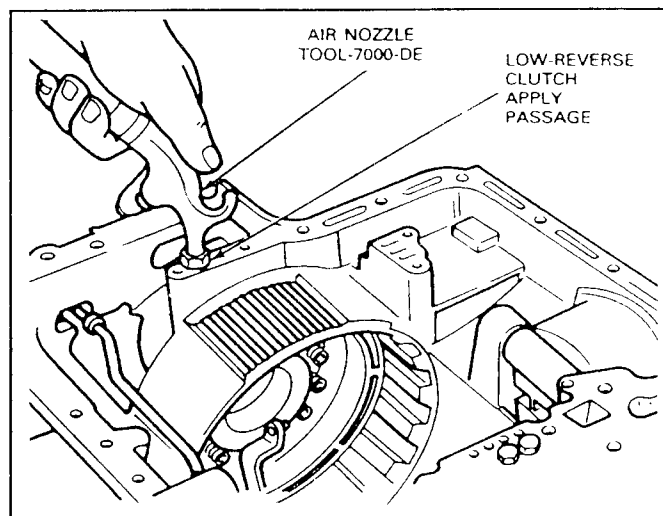

FIG. 23 Removing Low-Reverse Clutch Piston



16. Install the reverse planet ring gear thrust washer and the ring gear and hub assembly. Insert the snap ring in the groove on the output shaft.
17. Assemble the front and rear thrust washers onto the reverse planet assembly; retain with petroleum jelly. Insert the assembly into the ring gear and install the snap ring.
18. Set the reverse-high clutch assembly on the bench, with the front end facing down. Install the thrust washer on the rear end of the reverse-high clutch assembly. Retain the thrust washer with petroleum jelly and insert the splined end of forward clutch into the open end of the reverse-high clutch with splines engaging the direct clutch friction plates (Fig. 38).
19. Install the thrust washers and retain them with petroleum jelly, on the front end of the forward planet ring gear and hub. Insert the ring gear into the forward clutch.
20. Install the thrust washer on the front end of the forward planet assembly. Retain the washer with petroleum jelly and insert the assembly into the ring gear. Install the input shell and sun gear assembly.
21. Install the reverse-high clutch assembly, forward clutch assembly, forward planet assembly and drive input shell, and sun gear as an assembly into the transmission case.
22. Insert the intermediate band into the case around the reverse-high clutch drum. Install the struts and tighten the band adjusting screw sufficiently to retain the band.
23. Place a selective thickness bronze thrust washer on the rear shoulder of the stator support and retain it with petroleum jelly. If the end play was not within specification when checked prior to disassembly, replace the washer with one of proper thickness. Refer to specifications at the end of this Section for selective thrust washer thicknesses.

Using two 5/16-inch bolts three inches long, make two alignment studs. Cut the heads from the bolts and grind a taper on the cut end. Temporarily install the two studs opposite each other in the mounting holes of the case. Slide a new gasket onto the studs. Position pump on case, being careful not to damage the large seal on the outside diameter of the pump housing, (removing the aligning studs).

Install six of the seven mounting bolts and tighten to 22-40 N·m (16-30 ft-lbs).

24. Adjust the intermediate band as detailed under Adjustments and install the input shaft with the long splined end inserted into the forward clutch assembly.
25. Install Tool 4201-C or equivalent at the seventh pump mounting bolt (Fig. 18) and check the transmission end play as in steps 4, 5 and 6 of Disassembly. (See specifications at the end of this Section.) Remove the tool.
Install the seventh pump mounting bolt and tighten to 22-40 N·m (16-30 ft-lbs).
26. Install the main control valve body on the case, making sure that the levers engage the valves properly and tighten the attaching bolts to 11-14

N·m (95-125 in.-lbs). Install the primary throttle valve, rod, and the vacuum diaphragm in the case. Tighten the diaphragm attaching bolt to 17-21 N·m (12-16 ft-lbs).

27. Install a new pan gasket and the pan. Tighten the bolts to 10.5-17 N·m (8-12 ft-lbs).
28. Install the converter assembly.
29. Install the transmission in the vehicle as detailed under Removal and Installation.

Control Valve Body

Disassembly

The valve body-to-screen gasket should not be cleaned in a degreaser solvent or any type of detergent solution when disassembling the main control. To clean the gasket, wipe it off with a lint-free cloth.

1. Remove the nine screws that attach the screen to the lower valve body (Fig. 24) and remove screen and gasket (Fig. 25).
2. Remove the five upper-to-lower valve body and hold-down plate attaching screws. Remove the seven attaching screws from the underside of the lower valve body (Fig. 24).
3. Separate the bodies and remove the separator plate and gasket. **Be careful not to lose the check valves and springs.** Remove and clean the separator plate screen if necessary (Fig. 25).
4. Remove the manual valve retaining pin from the upper valve body (Fig. 26).
5. Slide the manual valve (Fig. 26) out of the valve body.
6. Cover the downshift valve bore with a finger, then working from the underside of the body remove the downshift valve retainer. Remove the spring and downshift valve (Fig. 26).
7. Apply hand pressure on the pressure boost valve sleeve end and remove the sleeve retaining clip from the under side of the body. Slowly release hand pressure and remove the sleeve and the pressure boost valve. Remove the two springs, the spring and the main regulator valve from the bore.
8. Apply pressure on the throttle boost valve retaining plate and remove the two attaching screws. Slowly release the pressure and remove plate, throttle pressure boost valve and spring, and the manual low 2-1 scheduling valve and spring from the body (Fig. 26).
9. Apply pressure on the remaining valve retaining plate and remove the eight attaching screws.
10. Hold the valve body so that the plate is facing upward. Slowly release the pressure and remove the plate.
11. Remove the spring and the intermediate servo modulator valve (Fig. 26) from the valve body.
12. Remove the intermediate servo accumulator valve and springs.
13. Remove the 2-3 back-out valve and spring.
14. Remove the 2-3 shift valve, spring and the throttle modulator valve and spring.
15. Remove the 1-2 shift valve, DR-2 shift valve and the spring from the valve body.

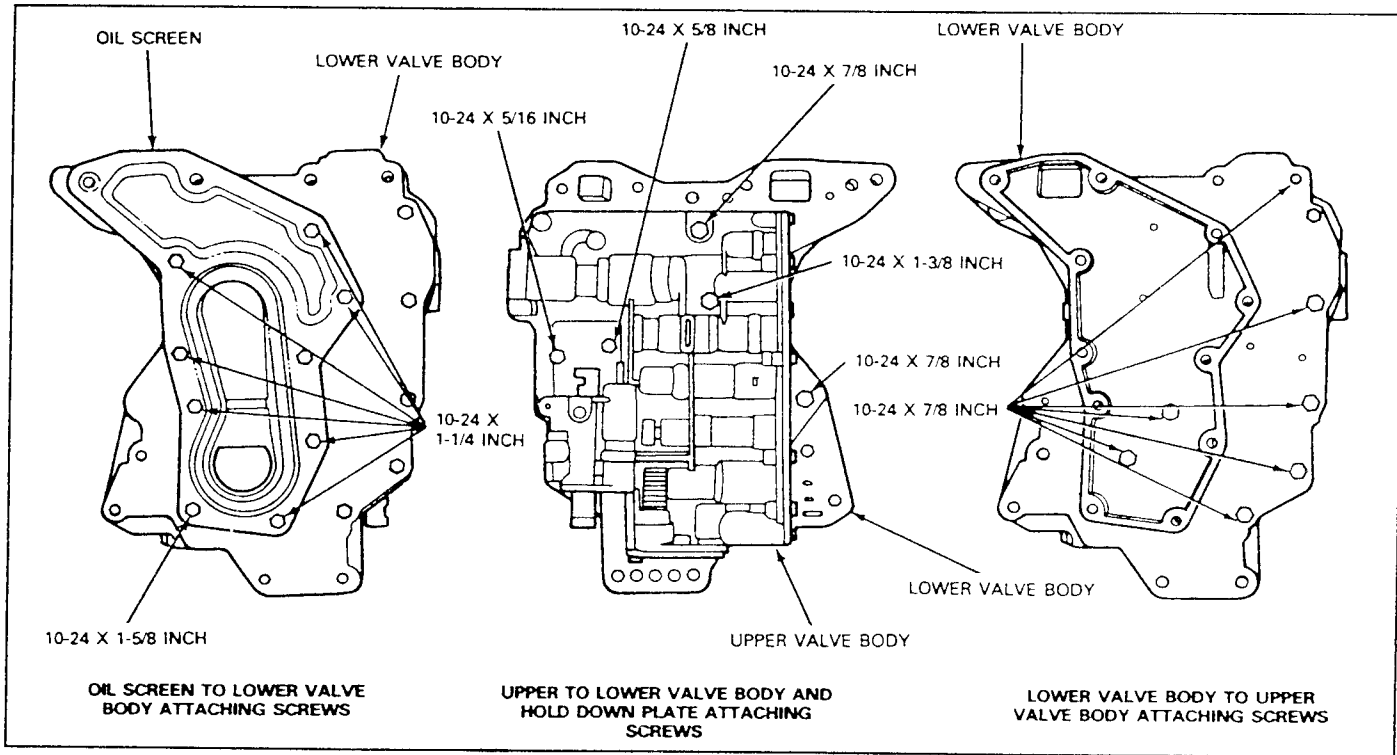

FIG. 24 Control Valve Body and Screen Attaching Screws

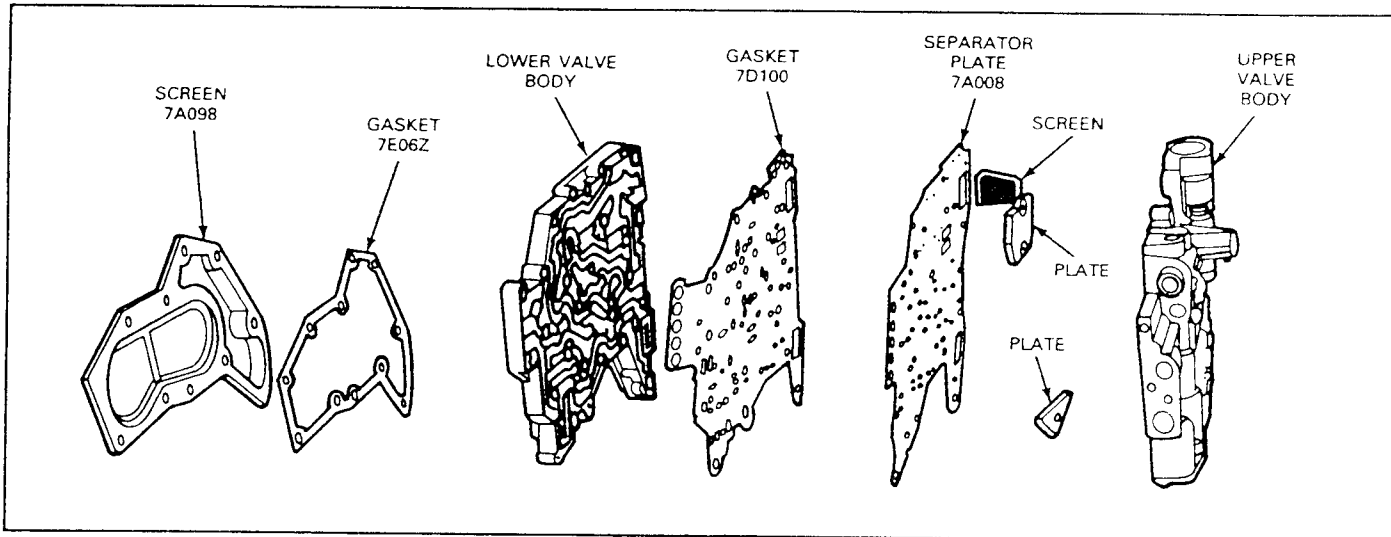

FIG. 25 Upper and Lower Valve Bodies Disassembled

16. Remove the line pressure coasting regulator valve, (Fig. 26) from the body.
17. Remove the cutback control valve to complete the disassembly of the control valve.

Assembly

1. Place the downshift valve and spring in the valve body. Compress the spring and install the retainer from the underside of the body (Fig. 27).
2. Place the valve body on a clean surface with the passage side facing up. Place the converter relief valve spring in its bore (Fig. 27). Coat the converter pressure relief valve with petroleum jelly and place it on top of the spring. Place the 2-3 shift valve check ball in its cavity. Place the throttle pressure

relief valve spring in its bore (Fig. 27). Coat the throttle pressure relief valve check ball with petroleum jelly and place it on top of the spring. Place the reverse clutch check ball in its cavity.

3. Install the separator screen in the separator plate if it was previously removed. **Be sure the screen tabs are flush with the separator plate surface.** Carefully position the separator plate and new gasket on the lower valve body. Place the two hold-down plates on the separator plate and install the attaching screws finger tight.
4. Place the lower body and plate assembly on the upper valve body (Fig. 24) and install the attaching screws finger tight.

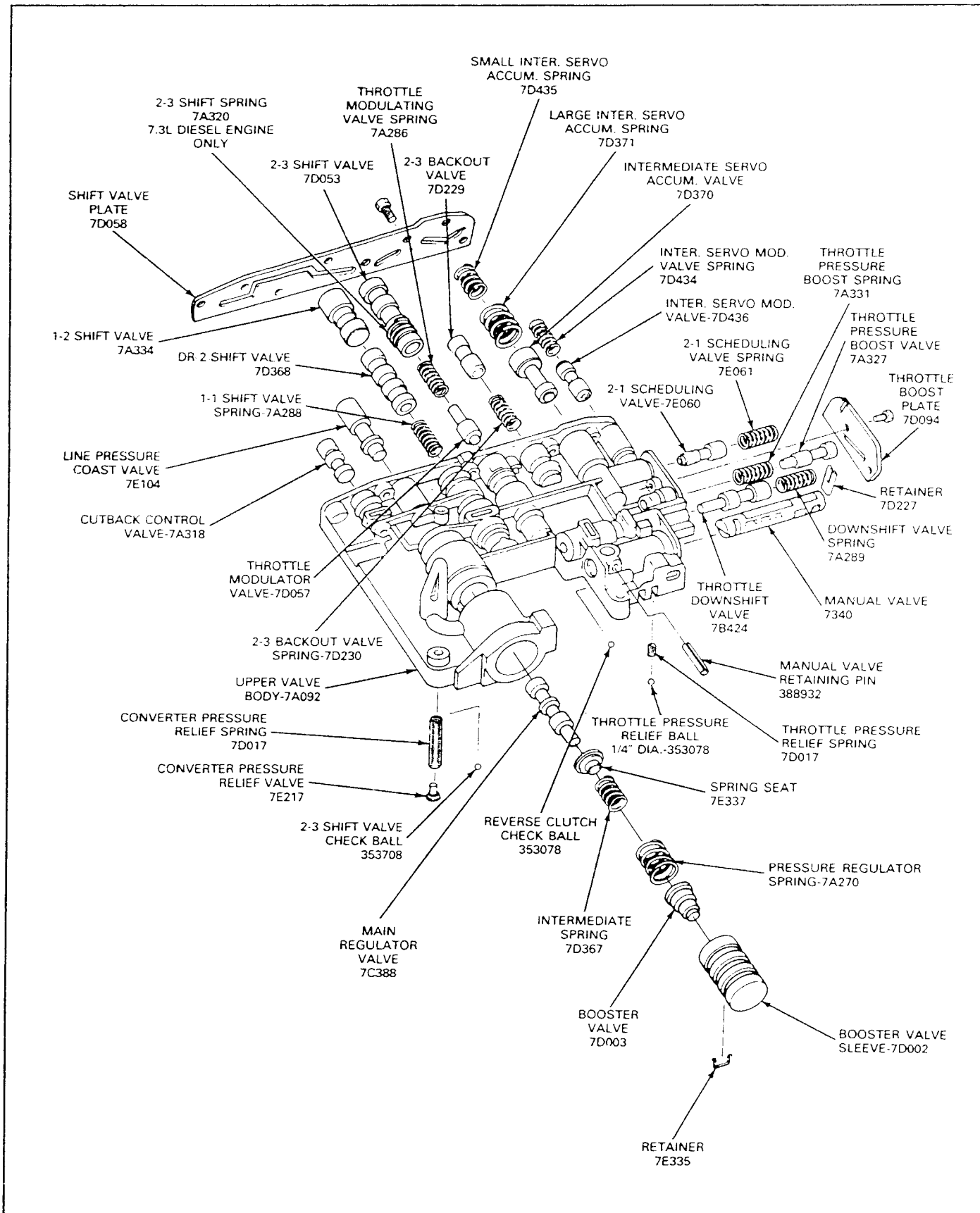

FIG. 26 Upper Valve Body Disassembled

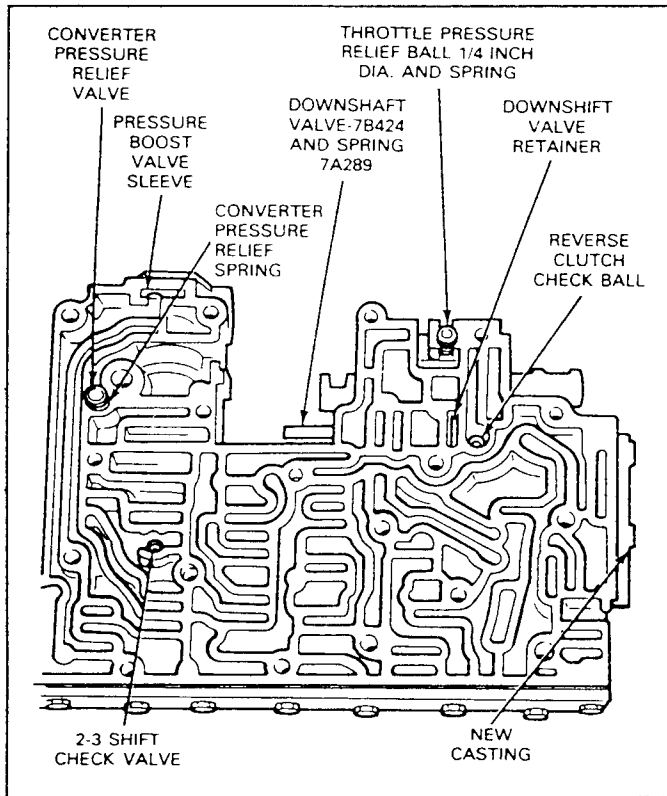

FIG. 27 Downshift Valve and Spring, Converter Pressure Relief Valve, Throttle Pressure Relief Valve Check Ball, and 2-3 Shift Check Valve Locations

5. Install the oil screen screws loosely, without the screen, to properly align the upper and lower valve bodies, gasket and separator plate.
6. Tighten the two bolts that are covered by the screen to 5.0-6.2 N·m (40-55 in.-lbs).
7. Remove the oil screen attaching screws and place the gasket and oil screen in position on the lower valve body. Re-install the screen attaching screws (Fig. 24).
8. Tighten all the valve body and screen attaching screws to 5.0-6.2 N·m (40-55 in.-lbs).
9. Place the cutback control valve (Fig. 26) and the line pressure coasting regulator valve in the valve body.
10. Place the one spring, DR-2 shift valve and the 1-2 shift valve in the body.
11. Place the throttle modulator valve and spring and the 2-3 shift valve (and spring on 7.3L Diesel) in the valve body.
12. Place the spring and the 2-3 backout valve in the valve body.
13. Place the two springs and the intermediate servo accumulator valve in the valve body.
14. Place the intermediate servo modulator valve and spring in the body.
15. Carefully place the valve retaining plate on the body and secure it with the eight attaching screws. Tighten the two hex washer head screws to 2.5-5.0 N·m (20-45 in.-lbs). Tighten the remaining six screws to 2.5-4.5 N·m (20-40 in.-lbs).

16. Place the throttle pressure boost valve and spring in the valve body. Place the manual low 2-1 scheduling valve and spring in the valve body and install the retaining plate. Tighten the attaching screws to 2.5-5.0 N·m (20-45 in.-lbs).
17. Place the spring seat on the stem of the main regulator valve so that the retainer flange is next to the valve shoulder. Place the main regulator valve, spring seat, two springs, pressure boost valve and sleeve in the bore. Apply hand pressure on the end of the pressure boost valve sleeve and install the spring clip retainer in the groove on the under side of the body so that the clip is inserted into the end groove in the sleeve. Be sure that the pressure boost valve sleeve is free in its bore.
18. Place the manual valve in the valve body and install the retaining pin in the body.

Intermediate Servo

(Refer to Fig. 10).

Disassembly

1. Apply air pressure to the port in the servo cover to remove the piston and rod.
2. Replace the complete piston and rod assembly if the piston or piston sealing lips are unserviceable or damaged.
3. Remove the seal and gasket from the cover.

Assembly

1. Dip the new seals in transmission fluid.
2. Install new seal and gasket on the cover.
3. Dip the piston in transmission fluid, Motorcraft MERCON® Multi-Purpose Automatic Transmission Fluid XT-2-QDX or DDX (ESP-M2C166-H), or equivalent and install it in the cover.

Governor

Disassembly

1. Remove the governor body attaching bolts and remove the governor.
2. Remove and discard the snap ring that secures the governor oil collector body on the output shaft (Fig. 28) and slide the governor off the front of the shaft.
3. Remove the seal rings from the oil collector body.

Assembly

1. Carefully install new seal rings on the oil collector body.
2. Working from the front end of the output shaft, slide the governor oil collector body into place on the shaft. Install a new snap ring to secure it. Make sure that the snap ring is seated in the groove.
3. Position the governor assembly on the oil collector body (Fig. 28) and secure with the attaching screws. Tighten screws to 10.5-13.5 N·m (90-120 in.-lbs).

Downshift and Manual Linkage

Disassembly

1. Remove the nut and lockwasher that secures the outer downshift lever to the transmission and remove the lever.

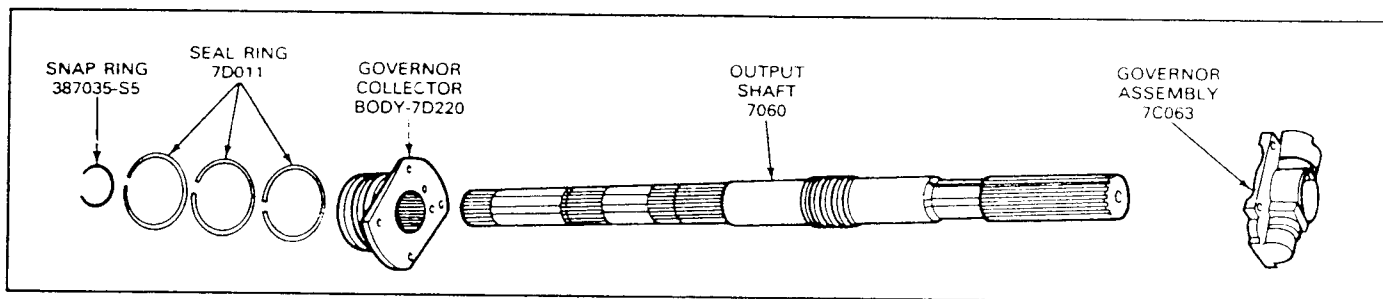

FIG. 28 Output Shaft Disassembled

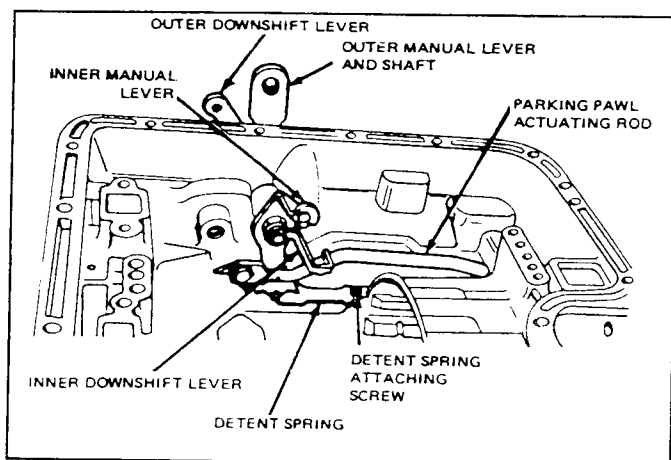

FIG. 29 Downshift and Manual Linkage

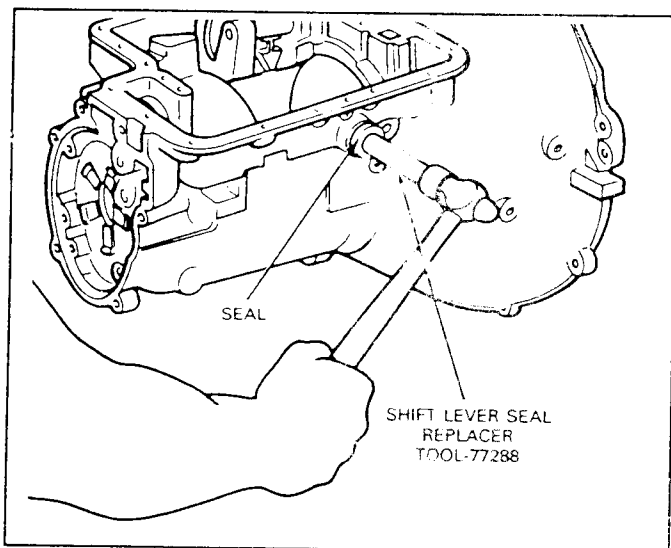

FIG. 30 Installing Manual Lever Seal

2. Slide the inner downshift lever assembly out from the inside of the case (Fig. 29). Remove the seal from the recess in the manual lever shaft.
3. Remove the two bolts retaining the neutral start switch, and remove the switch. (Fig. 6).
4. Remove the C-ring securing the parking pawl actuating rod to the manual lever. Remove the rod from the case.
5. Remove the nut securing the inner manual lever to the shaft. Remove the inner lever from the shaft. Slide the outer lever and shaft from the case.

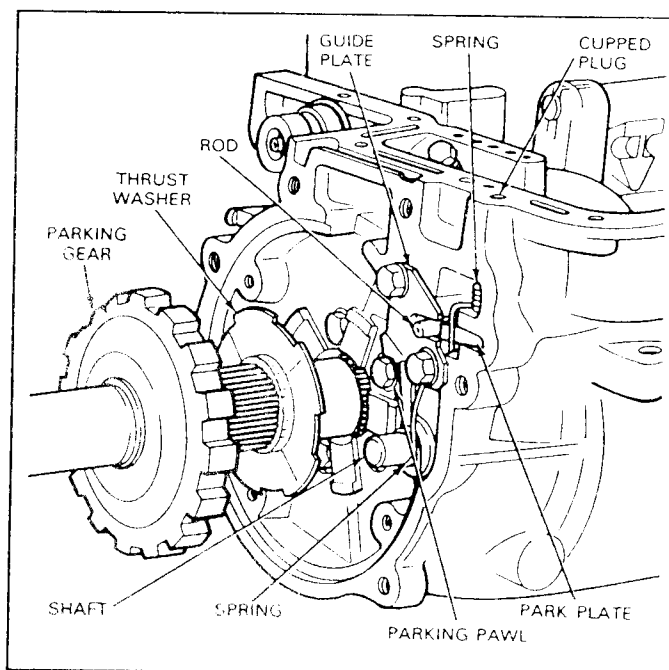

FIG. 31 Parking Pawl Mechanism

6. Remove the seal from the case with Tools T59L-100-B, Slide Hammer and T58L-101-B, Puller Attachment, or equivalents.

Assembly

1. Dip the new seal in transmission fluid Motorcraft MERCON® Multi-Purpose Automatic Transmission Fluid XT-2-QDX or DDX (ESP-M2C166-H), or equivalent and install it in the case using TOOL-77288 or equivalent as shown in Fig. 30.
2. Slide the outer manual lever and shaft in the transmission case.
3. Position the inner lever on the shaft, making sure the leaf spring roller is positioned in the inner manual lever detent. Install the attaching nut. Tighten the nut to 41-54 N·m (30-40 ft-lbs). Install the parking pawl actuating rod and secure it to the inner manual lever with a C-ring.
4. Slide the neutral-start switch on the outer lever shaft and install the bolts in the case.
5. With the transmission manual lever in neutral, rotate the switch and install the gauge pin (No. 43 drill) into the gauge pin hole aligning all three holes (Fig. 6) Tighten the bolts to 6.5-8.0 N·m (55-75 in.-lbs).

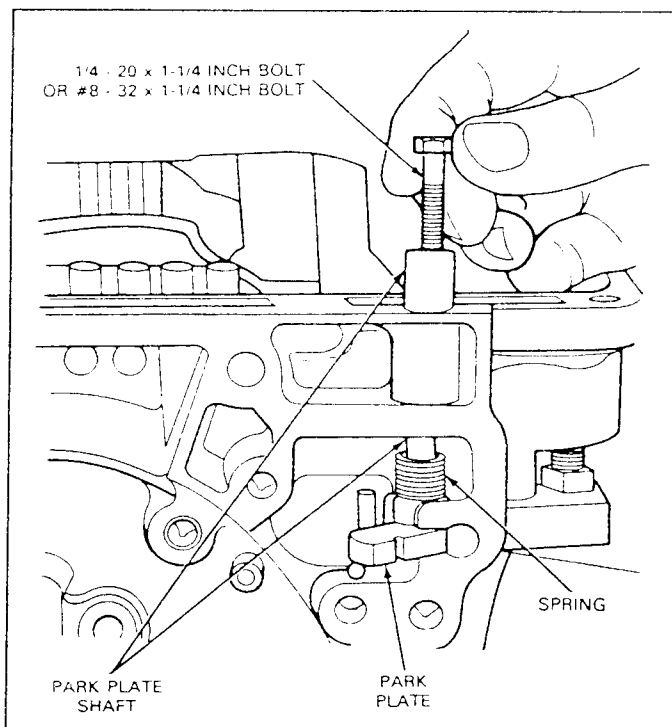

FIG. 32 Removing Park Plate

6. Install a new downshift lever seal in the recess of the outer lever shaft. Slide the downshift lever and shaft into position.
7. Place the outer downshift lever on the shaft and secure it with a lockwasher and nut. Tighten nut to 17-21 N·m (12-16 ft-lbs).

Parking Pawl Linkage

Disassembly

1. Remove the bolts securing the parking pawl guide plate to the case (Fig. 31). Remove the plate.
2. Remove the spring, parking pawl and shaft from the case.
3. Working from the pan mounting surface, drill a 1/8 inch diameter hole through the center of the cupped plug. Pull the plug from the case with a wire hook.
4. Unhook the end of the spring from the park plate slot to relieve the tension.
5. Thread a 1/4-20 inch or 8-32 x 1-1/4 inch screw (Fig. 32) into the park plate shaft. Pull the shaft from the case with the screw. Remove the spring and park plate.

Assembly

1. Position the spring and park plate in the case and install the shaft. Place the end of the spring into the slot of the park plate.
2. Install a new cupped plug to retain the shaft.
3. Install the parking pawl shaft in the case. Slip the parking pawl and spring into place on the shaft.
4. Position the guide plate on the case, making sure that the actuating rod is seated in the slot of the plate. Secure the plate with two bolts and lockwashers. Tighten bolts to 17-21 N·m (12-16 ft-lbs).

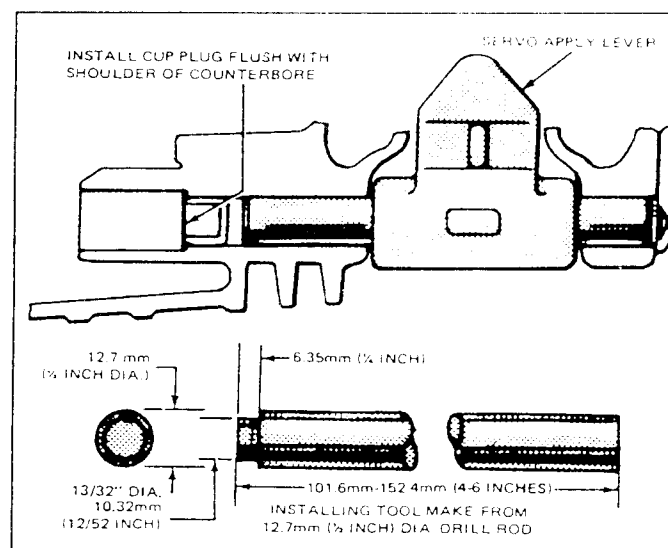

FIG. 33 Servo Apply Lever Installation

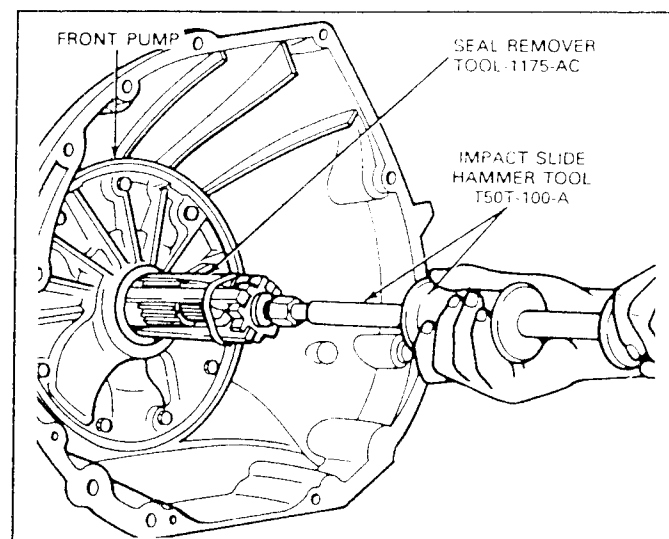

FIG. 34 Removing Front Pump Seal

Servo Apply Lever

Disassembly

1. Working from inside of the transmission case, carefully drive on the servo apply lever shaft to remove the cup plug. The shaft (Fig. 33) can be withdrawn from the case by hand.

Assembly

1. Hold the servo apply lever in position and install the new shaft.
2. Using the fabricated tool shown in Fig. 33, drive the cup plug into position in the case. Be sure the plug is flush with the shoulder of the counterbore. The cup plug may be coated with Threadlock and Sealer, EOAZ-19554-AA (ESE-M4G204-A) or equivalent, before installation.

Front Pump

The front seal can be replaced after the pump has been installed on the transmission using T50T-100-A and TOOL-1175-AC or equivalent for removal, and

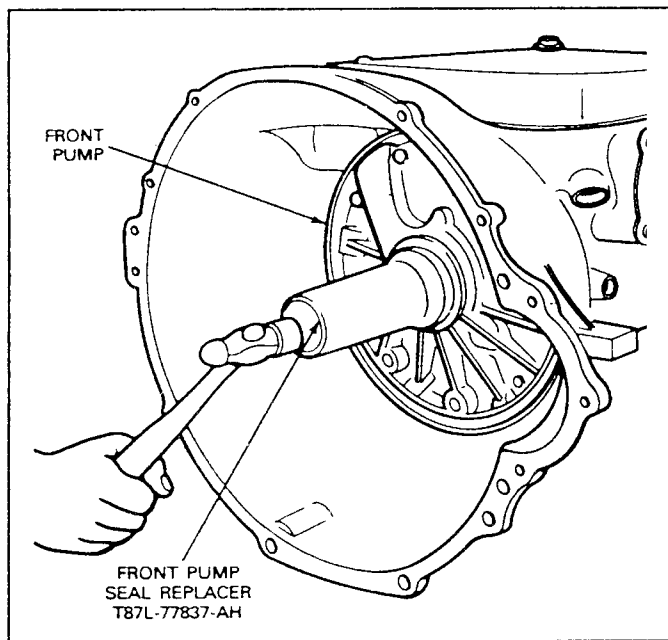

FIG. 35 Installing Front-Pump Seal

T87L-77837-AH or equivalent for installation (Figs. 34 and 35).

Disassembly

1. Remove the two seal rings and the selective thrust washer (Fig. 36).
2. Remove the large square-cut seal from the outside diameter of the pump housing.
3. Remove the five bolts that secure the stator support to the pump housing. Lift the support from the housing.
4. Remove the drive and the driven gear from the housing.
5. If the pump housing bushing is worn or damaged, replace it using the handle and Tool T66L-7003-C2 or equivalent shown in Fig. 37.

Place the new bushing in position, making sure the half moon slot in the bushing is on top and in line with the oil lube hole near the seal bore. Press

the bushing in 1.52-2.03mm (0.060-0.080 inch) below the front face of the bushing bore. Use Tool T66L-7003-C2 or equivalent and handle to seat the bushing properly. After assembly, the half moon slot must be in past the lube hole to provide proper lubrication.

Assembly

1. Install the drive and driven gears in the pump housing. **Each gear has either an identification mark or chamfered teeth on one face. The identification mark or the chamfered surface on each gear must be installed toward the front of the pump housing.**
2. Position the stator support in the pump housing and install the five attaching bolts. Tighten bolts to 17-21 N·m (12-16 ft-lbs).
3. Carefully install two new seal rings on the stator support. Make sure that the ends of the rings are engaged to lock them in place. Install a new square-cut seal on the outside diameter of the pump housing.
4. Install the selective thrust washer. **Make sure that the correct thickness selective washer is being used to obtain the specified end play.** Refer to Specifications at end of this Section.
5. Place the pump on the converter, making sure that the drive gear engages the converter hub. Rotate the pump to make sure that the gears rotate freely.

Reverse-High Clutch

Disassembly

1. Separate the drive train as shown in Fig. 38. Remove the pressure plate snap ring as shown in Fig. 39.
2. Remove the pressure plate and the drive and driven (internal and external spline) clutch plates (Fig. 40).
3. Install Clutch Spring Compressor, Tool T65L-77515-A (Fig. 41) on the reverse-high clutch drum. Make sure that the legs clear the snap ring enough to remove it. Remove the snap ring and remove the tool.

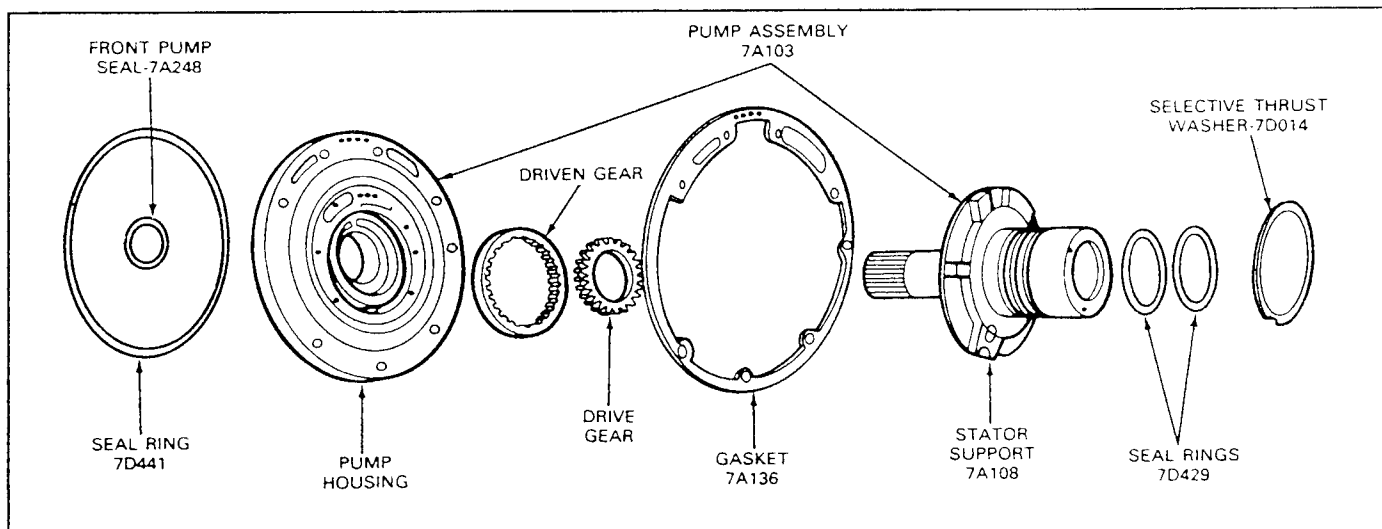

FIG. 36 Front Pump Disassembled

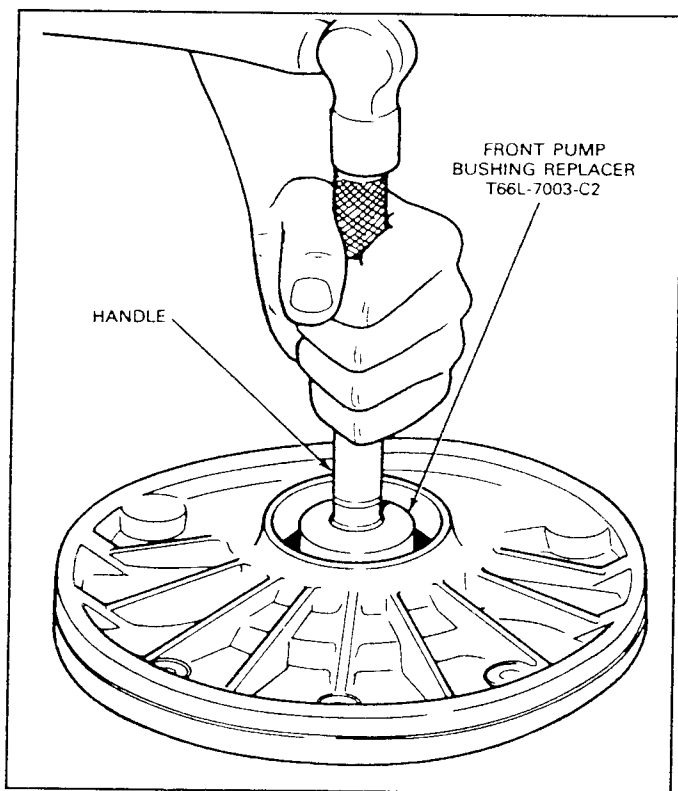

FIG. 37 Replacing Front Pump Housing Bushing

4. Remove the spring retainer and the piston return springs.
5. Apply air pressure to the piston apply hole in the clutch hub using TOOL-7000-DE or equivalent (Fig. 42) and remove the piston.
6. Remove the piston outer seal from the piston and the inner seal from the clutch drum (Fig. 40).
7. Remove the front and rear bushings from the clutch drum if they are worn or damaged. To remove the front bushing, use a cape chisel and cut along the bushing seam until the chisel breaks through the bushing wall. Pry the loose ends of the bushing up with an awl and remove the bushing. To remove the rear bushing, use Tool T69L-7D044-B or equivalent shown in Fig. 43, and press the bushing from the drum.

Assembly

1. If the clutch drum bushings were removed, position the drum in a press and press new bushings into the drum with the Tool T69L-7D044-B or equivalent shown in Figs. 43 and 44.
2. Dip the new seals in transmission fluid and install one on the drum and one on the piston.
3. Install the piston in the clutch drum.
4. Position the piston return springs in the piston sockets (Fig. 45). Place the spring retainer on the springs.
5. Install Clutch Spring Compressor, Tool T65L-77515-A (Fig. 41) and compress the springs. Make certain that the spring retainer is centered while compressing the springs. Install the snap ring. **Before releasing the pressure on the tool, make certain that the snap ring is positioned**

inside of the four snap ring guides on the spring retainer.

6. Clutch plate usage varies with each model, refer to the specifications at end of this Section for the number of plates required. Dip the clutch plates in clean transmission fluid. Install the clutch plates alternately starting with a steel drive (internal) plate (Fig. 40). When new composition clutch plates are used, soak the plates in automatic transmission fluid, Motorcraft MERCON® Multi-Purpose Automatic Transmission Fluid XT-2-QDX or DDX (ESP-M2C166-H) or equivalent, for 15 minutes before they are assembled.
7. After all clutch plates have been installed, position the pressure plate in the clutch drum. Install the pressure plate (selective) snap ring.
8. With a feeler gauge, check the clearance between the pressure plate and snap ring (Fig. 46).
9. The pressure plate should be held downward as the clearance is checked. The clearance should be 0.558-0.914mm (0.022-0.036 inch). If the clearance is not within specifications, selective thickness snap rings are available in the following thicknesses: 1.42-1.52mm (0.056-0.060 inch), 1.65-1.75mm (0.065-0.069 inch), 1.87-1.98mm (0.074-0.078 inch), 2.10-2.20mm (0.083-0.087 inch), 2.33-2.43mm (0.092-0.096 inch), 2.79-2.89mm (0.110-0.114 inch) and 3.25-3.35mm (0.128-0.132 inch). Install the correct size snap ring and re-check the clearance.

Forward Clutch

Disassembly

1. Remove the clutch pressure plate snap ring (Fig. 47).
2. Remove the rear pressure plate, the drive and driven plates, wave plate, and the forward pressure plate from the clutch hub (Fig. 48).
3. Remove the snap ring (Fig. 49) that secures the disc spring in the clutch cylinder. Remove the disc spring and steel ring using Tool T65L-77515-A.
4. Apply air pressure to the clutch cylinder using TOOL-7000-DE or equivalent (Fig. 50) to remove the piston.
5. Remove the seal from the piston and the seal from the clutch hub (Fig. 48).

Assembly

1. Dip two new seals in transmission fluid, Motorcraft MERCON® Multi-Purpose Automatic Transmission Fluid XT-2-QDX or DDX (ESP-M2C166-H) or equivalent. Install the smaller seal on the clutch hub and the lip seal on the clutch piston.
2. Install the clutch piston and lip seal with Lip Seal Protector, T77L-77548-A, (Fig. 51).
3. Position the installation tool into the forward clutch cylinder, so that the bore of the tool is aligned with the piston bore in the cylinder. Press the piston into the cylinder until it bottoms in the bore. Remove the installation tool.
4. Make sure that the steel pressure ring is in the groove on the piston. **Position the disc spring in the cylinder with the dished face downward.** Install the spring as shown in Fig. 49 so that the

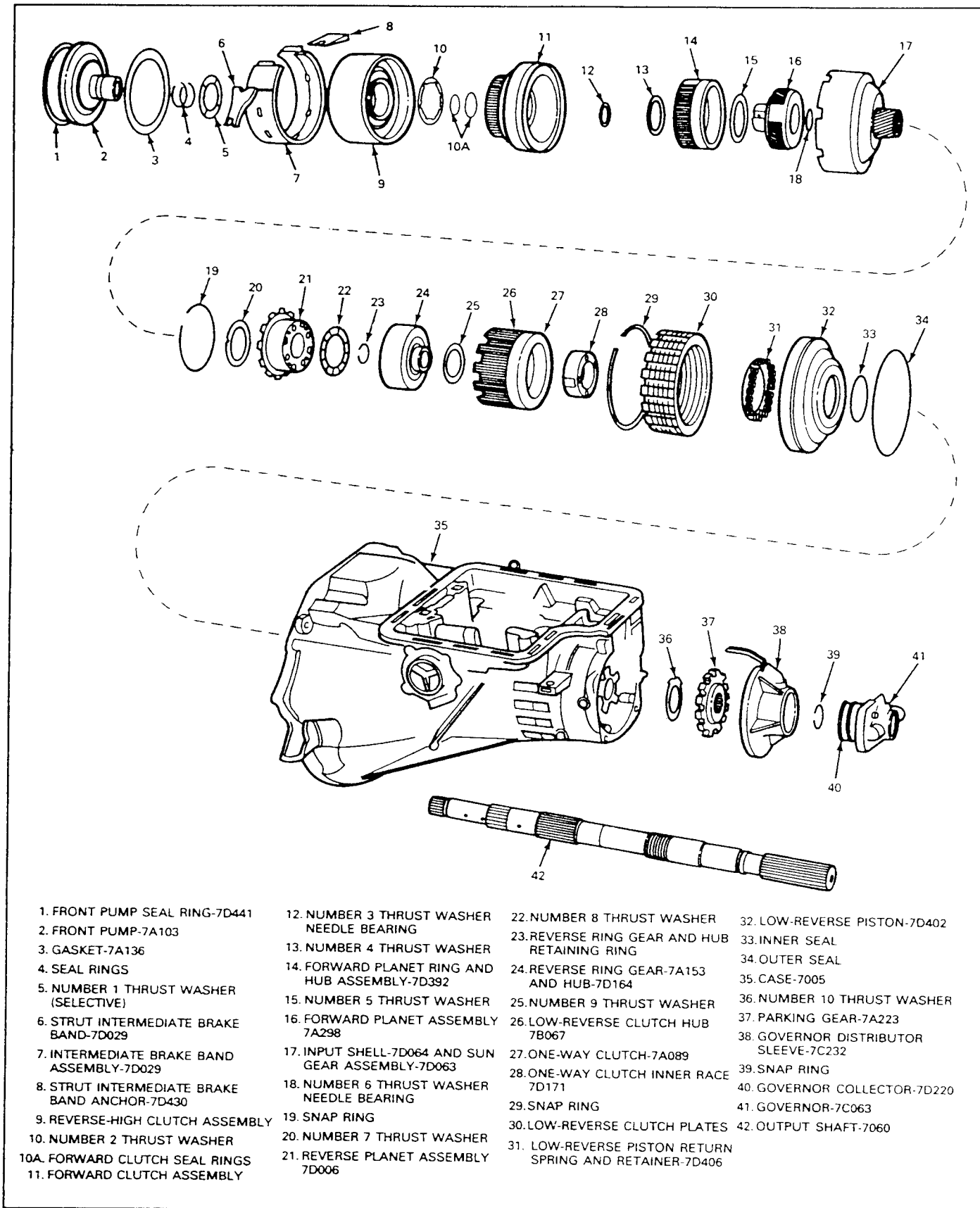

- | | | | |
|--|--|--|--|
| 1. FRONT PUMP SEAL RING-7D441 | 12. NUMBER 3 THRUST WASHER
NEEDLE BEARING | 22. NUMBER 8 THRUST WASHER | 32. LOW-REVERSE PISTON-7D402 |
| 2. FRONT PUMP-7A103 | 13. NUMBER 4 THRUST WASHER | 23. REVERSE RING GEAR AND HUB
RETAINING RING | 33. INNER SEAL |
| 3. GASKET-7A136 | 14. FORWARD PLANET RING AND
HUB ASSEMBLY-7D392 | 24. REVERSE RING GEAR-7A153
AND HUB-7D164 | 34. OUTER SEAL |
| 4. SEAL RINGS | 15. NUMBER 5 THRUST WASHER | 25. NUMBER 9 THRUST WASHER | 35. CASE-7005 |
| 5. NUMBER 1 THRUST WASHER
(SELECTIVE) | 16. FORWARD PLANET ASSEMBLY
7A298 | 26. LOW-REVERSE CLUTCH HUB
7B067 | 36. NUMBER 10 THRUST WASHER |
| 6. STRUT INTERMEDIATE BRAKE
BAND-7D029 | 17. INPUT SHELL-7D064 AND SUN
GEAR ASSEMBLY-7D063 | 27. ONE-WAY CLUTCH-7A089 | 37. PARKING GEAR-7A223 |
| 7. INTERMEDIATE BRAKE BAND
ASSEMBLY-7D029 | 18. NUMBER 6 THRUST WASHER
NEEDLE BEARING | 28. ONE-WAY CLUTCH INNER RACE
7D171 | 38. GOVERNOR DISTRIBUTOR
SLEEVE-7C232 |
| 8. STRUT INTERMEDIATE BRAKE
BAND ANCHOR-7D430 | 19. SNAP RING | 29. SNAP RING | 39. SNAP RING |
| 9. REVERSE-HIGH CLUTCH ASSEMBLY | 20. NUMBER 7 THRUST WASHER | 30. LOW-REVERSE CLUTCH PLATES | 40. GOVERNOR COLLECTOR-7D220 |
| 10. NUMBER 2 THRUST WASHER | 21. REVERSE PLANET ASSEMBLY
7D006 | 31. LOW-REVERSE PISTON RETURN
SPRING AND RETAINER-7D406 | 41. GOVERNOR-7C063 |
| 10A. FORWARD CLUTCH SEAL RINGS | | | 42. OUTPUT SHAFT-7060 |
| 11. FORWARD CLUTCH ASSEMBLY | | | |

FIG. 38 Drive Train Disassembled—Typical

pressure ring and spring are in contact. Secure the disc with the retaining snap ring.

5. Install the forward pressure plate with the flat side up and the beveled side downward. Dip the clutch plates in clean transmission fluid (Specification Motorcraft MERCON® Multi-Purpose Automatic Transmission Fluid XT-2-QDX or DDX (ESP-M2C166-H) or equivalent). Next, install the wave plate, then a steel plate and a composition driven plate. Install the remaining plates in this sequence (Fig. 48).

Refer to the Specification at end of this Section for the number of plates required. The last plate installed will be the rear pressure plate. Install the snap ring and make certain that it seats fully in the groove.

6. With a feeler gauge, check the clearance between the snap ring and the pressure plate (Fig. 52). Downward pressure on the plate should be maintained when making this check. Clearance should be 0.533-1.168mm (0.021-0.046 inch).

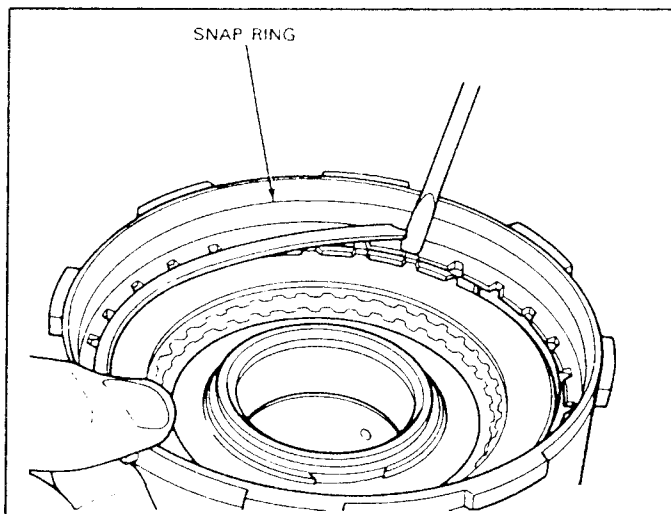

FIG. 39 Removing or Installing Reverse-High Clutch Pressure Plate Snap Ring

7. If the clearance is not within specifications, selective snap rings are available in the following thicknesses: 1.42-1.52mm (0.056-0.060 inch), 1.65-1.75mm (0.065-0.069 inch), 1.87-1.98mm (0.074-0.078 inch), 2.10-2.20mm (0.083-0.087 inch), 2.33-2.43mm (0.092-0.096 inch), 2.79-2.89mm (0.110-0.114 inch) and 3.25-3.35mm (0.128-0.132 inch). Insert the correct size snap ring and recheck the clearance.

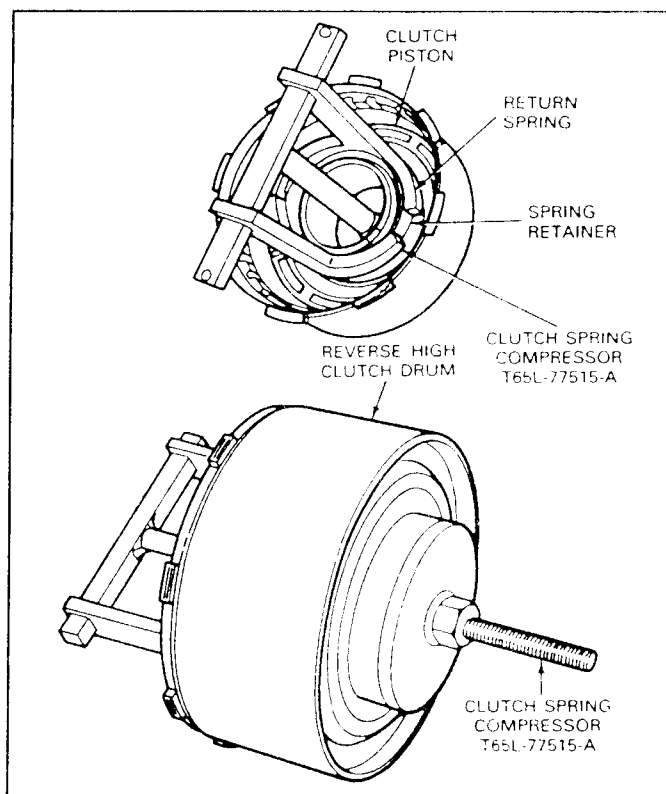

FIG. 41 Removing or Installing Reverse—High Clutch Piston Snap Ring

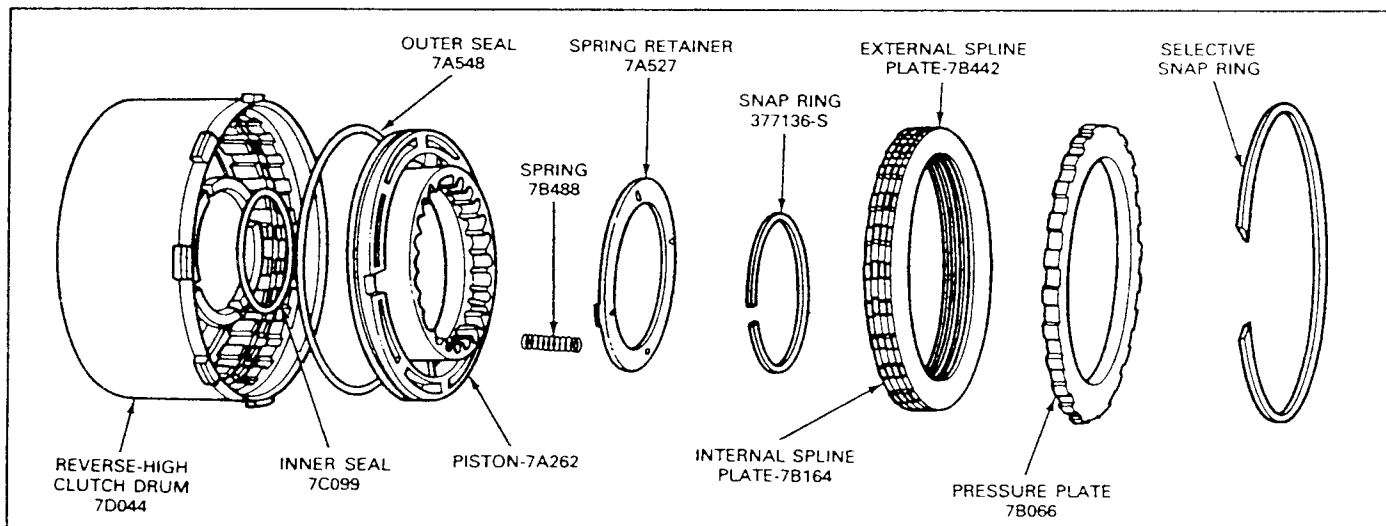

FIG. 40 Reverse-High Clutch Disassembled

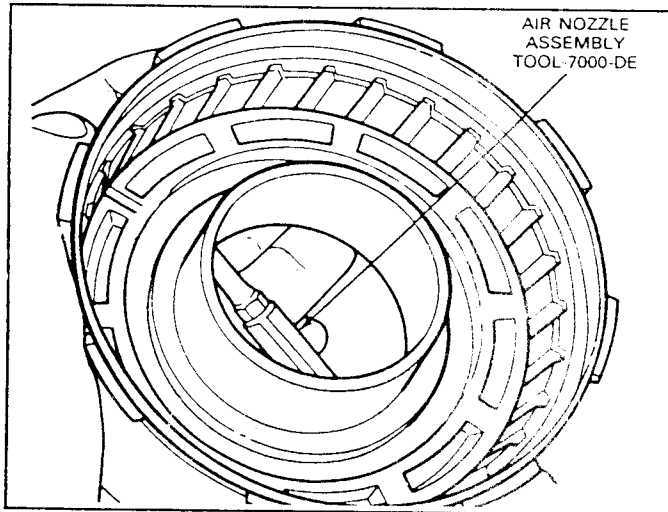

FIG. 42 Removing Reverse-High Clutch Piston

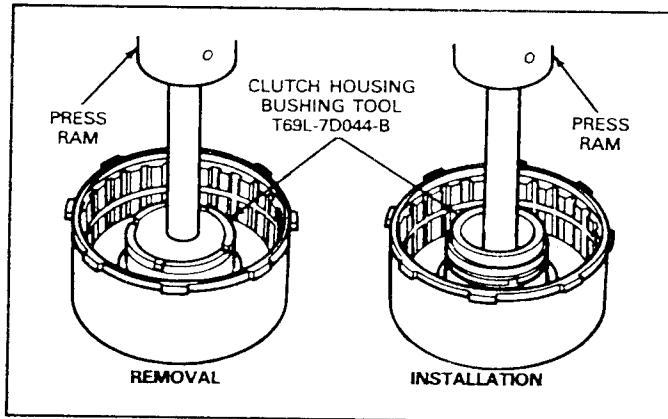

FIG. 43 Replacing Reverse-High Clutch Rear Bushing

Input Shell and Sun Gear

Disassembly

1. Remove the rear snap ring from the sun gear as shown in Fig. 53.
2. Remove the thrust washer wear plate from the input shell and sun gear (Fig. 54).
3. Working from inside the input shell remove the sun gear. Remove the snap ring from the gear.

Assembly

1. Install the forward snap ring on the forward end (short end) of the sun gear (Fig. 54). Working from inside the input shell, slide the sun gear and snap ring into place making sure that the longer end is at the rear (Fig. 54).
2. Place the thrust washer wear plate on the sun gear and install the rear snap ring.

Output Shaft Hub and Ring Gear

Disassembly

1. Remove the hub snap ring (Fig. 55) from the ring gear.
2. Lift the hub from the ring gear.

Assembly

1. Position the hub in the ring gear.

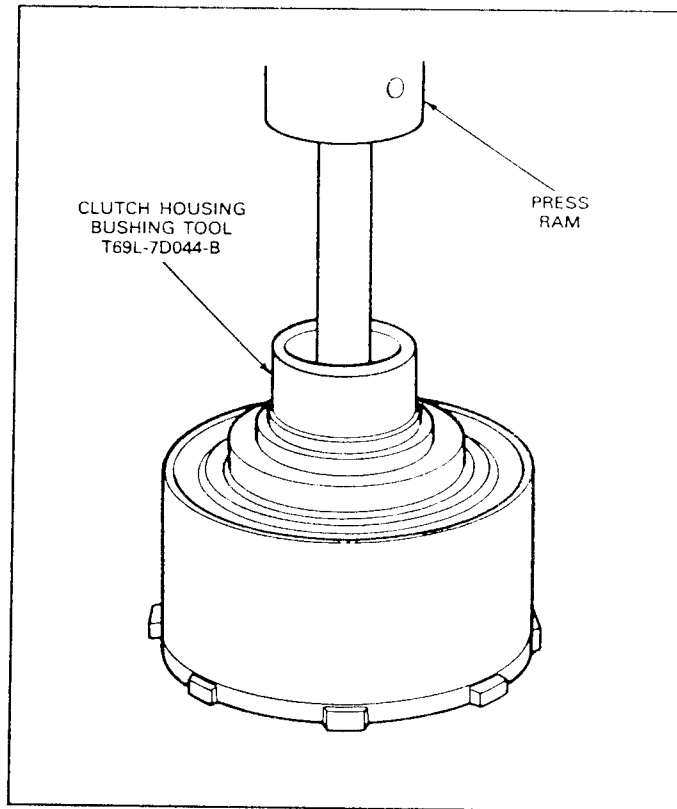

FIG. 44 Installing Reverse-High Clutch Front Bushing

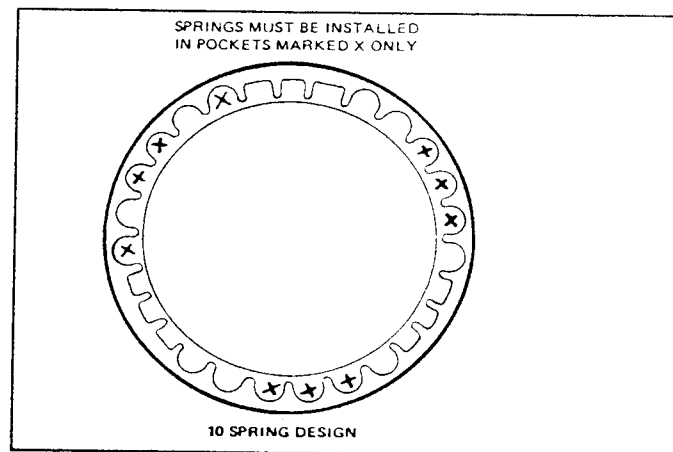

FIG. 45 Reverse-High Clutch Piston Return Spring Locations

2. Secure the hub with the snap ring. Make certain that the snap ring is fully engaged with the groove.

One-Way Clutch

Disassembly

1. Remove the snap ring and bushing from the rear of the low-reverse clutch hub (Fig. 56).
2. Remove the rollers from the spring assembly and lift the spring assembly from the hub.
3. Remove the remaining snap ring from the hub.

Assembly

1. Install a snap ring in the forward snap ring groove of the low-reverse clutch hub.

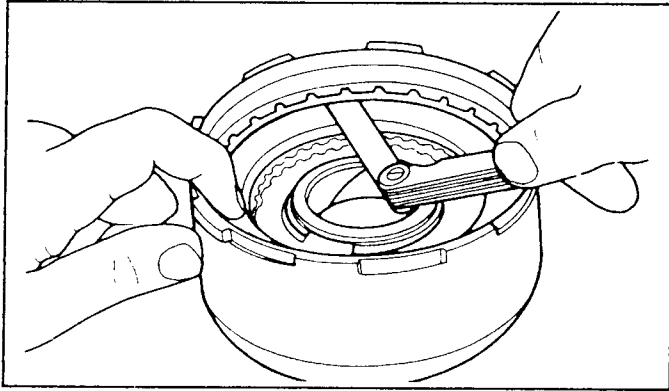

FIG. 46 Checking Reverse-High Clutch Snap Ring Clearance

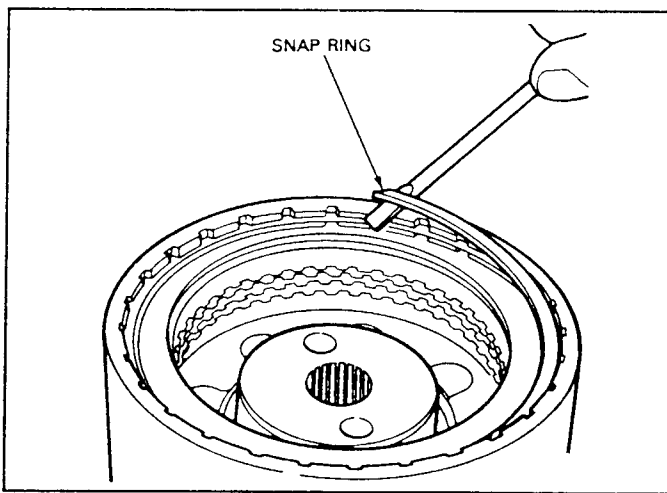

FIG. 47 Removing Forward Clutch Pressure Plate Snap Ring

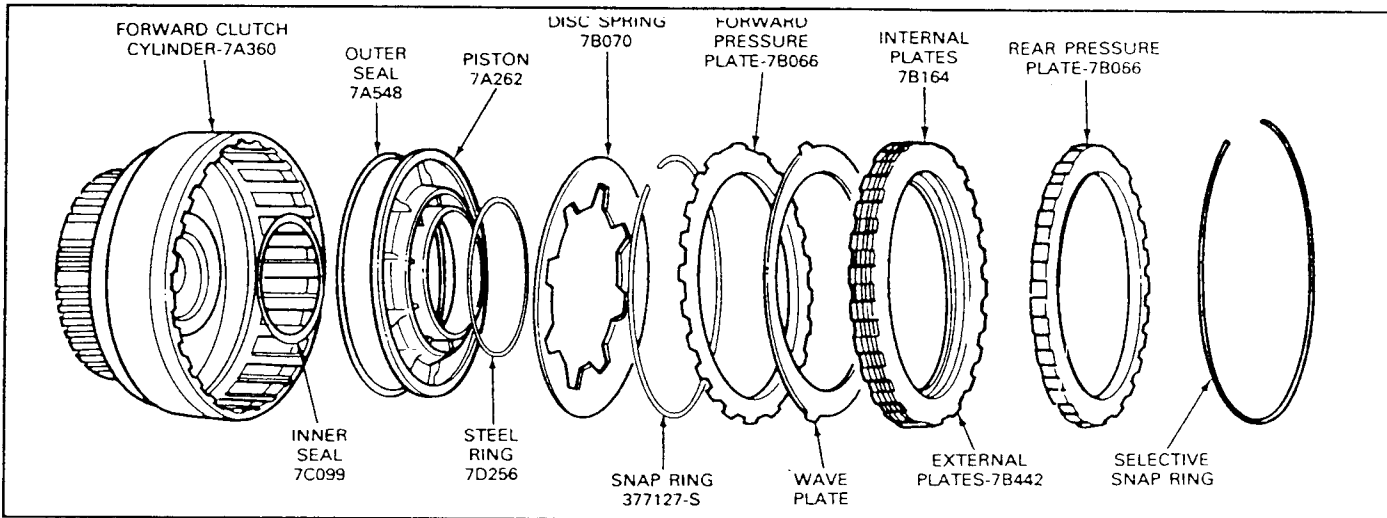

FIG. 48 Forward Clutch Disassembled

2. Place the low-reverse clutch hub on the bench with the forward end down (Fig. 57).
3. Install the one-way clutch spring assembly on top of the snap ring.
4. Install a roller into each of the spring assembly compartments (Fig. 56).
5. Install the bushing on top of the spring assembly.
6. Install the remaining snap ring at the rear of the low-reverse clutch hub to secure the assembly (Fig. 56).

Low-Reverse Clutch Piston

Disassembly

1. Remove the inner and the outer seal from the low-reverse clutch piston (Fig. 38).

Assembly

1. Dip the two new seals in clean transmission fluid, Motorcraft MERCON® Multi-purpose Automatic Transmission Fluid XT-2-QDX or DDX (ESP-M2C166-H) or equivalent.
2. Install the seals on the piston.

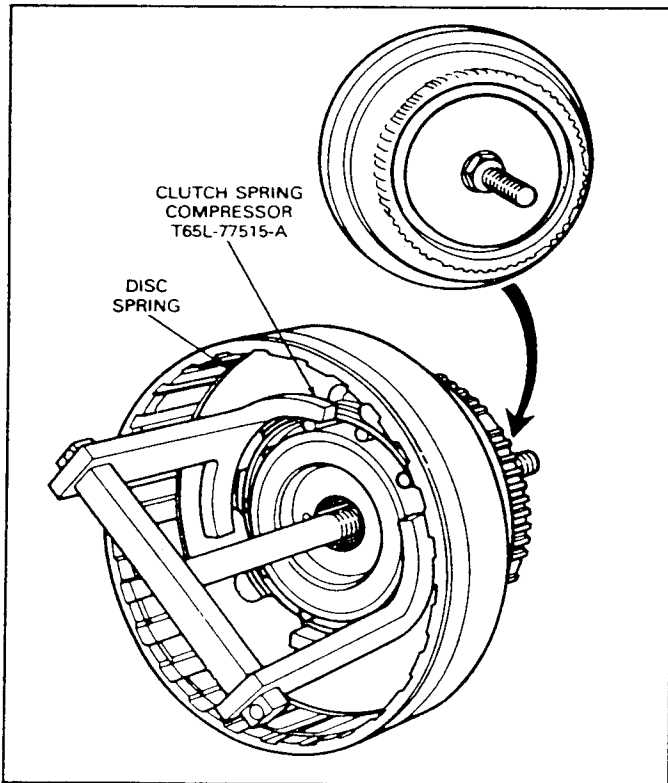

FIG. 49 Removing or Installing Disc Spring

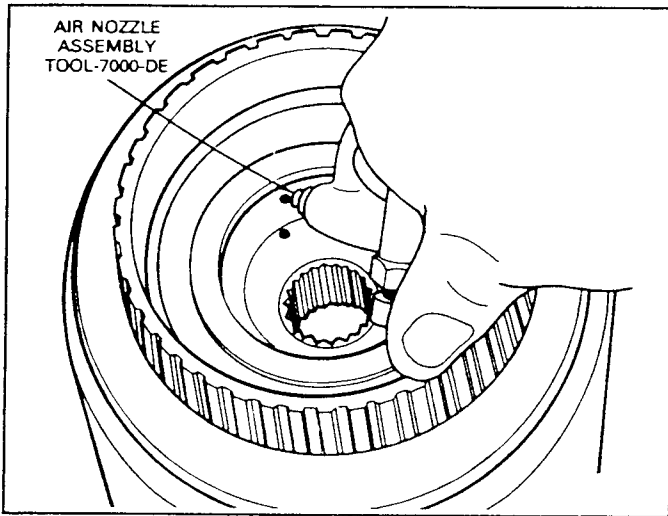

FIG. 50 Removing Forward Clutch Piston

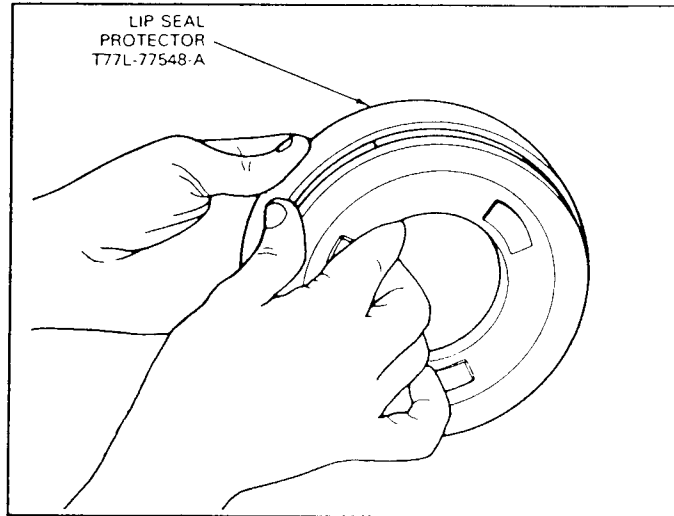

FIG. 51 Installing Forward Clutch Piston and Lip Seal

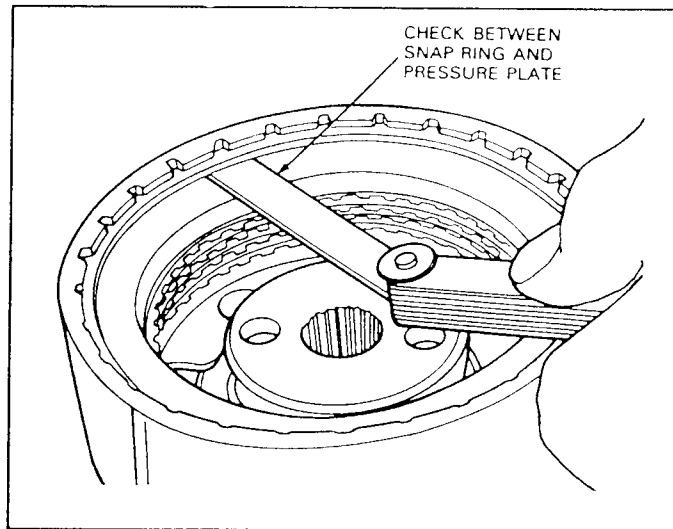

FIG. 52 Checking Forward Clutch Clearance

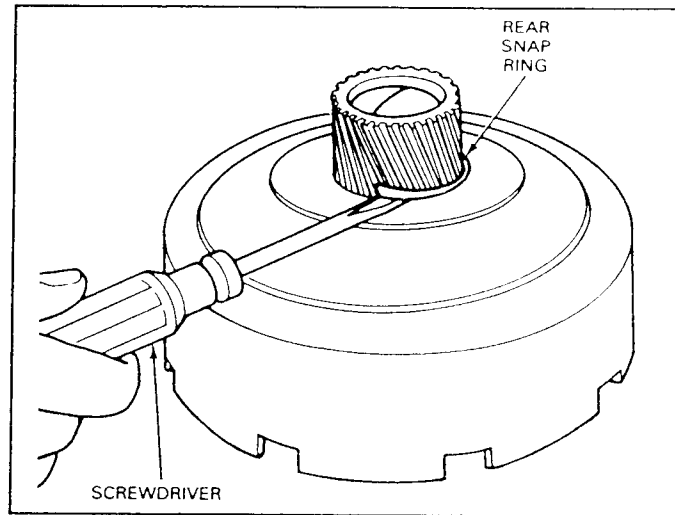

FIG. 53 Removing Sun Gear Snap Ring

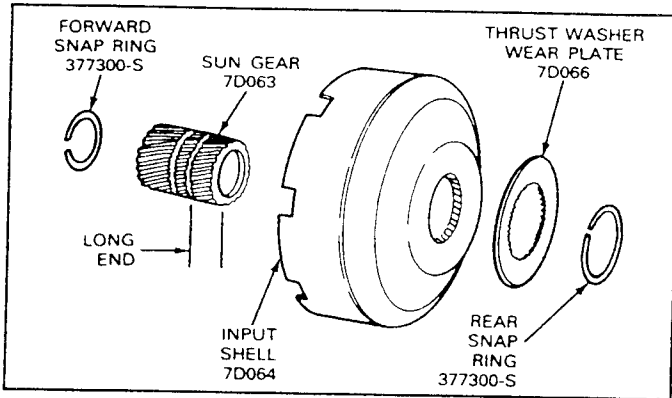

FIG. 54 Input Shell and Sun Gear Disassembled

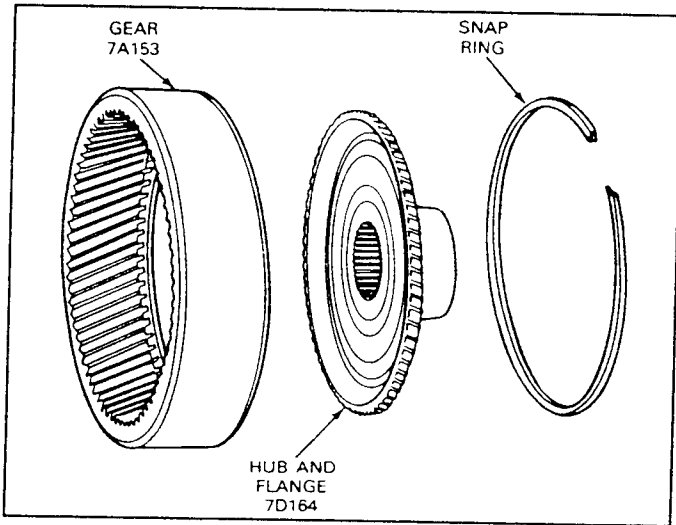

FIG. 55 Output Shaft Hub and Ring Gear

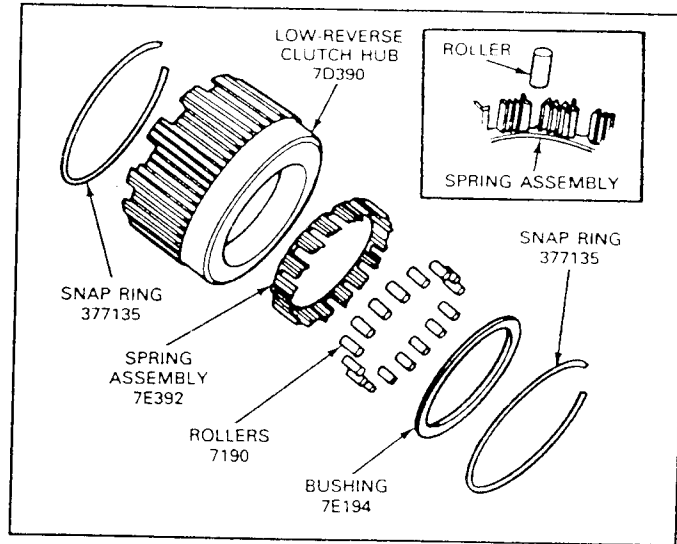

FIG. 56 One-Way Clutch Disassembled

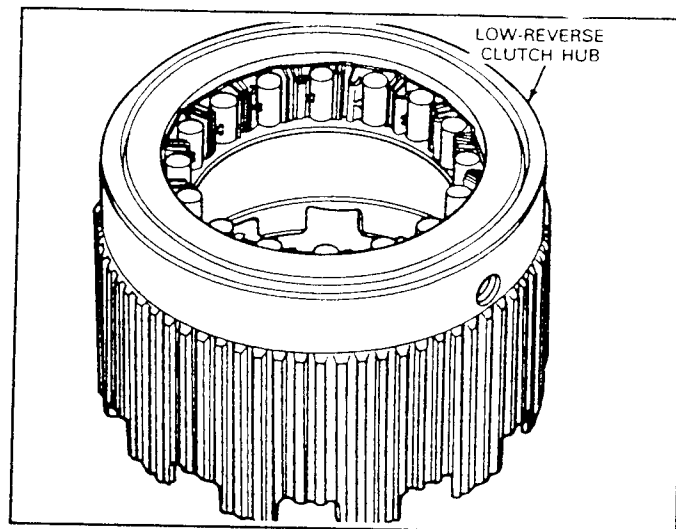

FIG. 57 One-Way Clutch Installed



Technical Service Information

SPECIFICATIONS

C6 — TRANSMISSION REFILL CAPACITY

Vehicle	U.S. Quarts	Capacity Imperial Quarts	Liters
F-150 — F-350 (4 x 2), E-150 — E-350	11-3/4	9.4	11.2
F-150 — F-350 (4 x 4), Bronco	13-1/2	10.8	12.7

Use fluid Motorcraft MERCON® Multi-Purpose Automatic Transmission Fluid XT-2-QDX or DDX (ESP-M2C166-H) or equivalent.

SELECTIVE THRUST WASHERS (FRONT PUMP SUPPORT)

Identification Color	Thickness	
	MM	Inch
Blue	1.42-1.52	0.056-0.060
Natural (White)	1.85-1.95	0.073-0.077
Red	2.23-2.33	0.088-0.092

TRANSMISSION CLUTCH PLATE USAGE

Transmission Model	Steel	Friction	Clearance	
			MM	Inch
Forward Clutch				
PGD, PJD	4 ^①	4	0.533-1.168	0.021-0.046
High Clutch				
PGD, PJD	3	3	0.558-0.914	0.022-0.036
Reverse Clutch				
PJD	5 ^②	5	—	—
PGD	4 ^②	4	—	—

① Plus a waved plate (7E457) next to inner pressure plate.

② Plus a waved plate next to the piston.

CLUTCH SNAP RINGS

Part Number	Thickness		Forward	High
	MM	Inch		
377434	1.52-1.42	0.060-0.056	X	X
377126	1.75-1.62	0.069-0.064		X
377127	1.98-1.87	0.078-0.074	X	X
377128	2.20-2.10	0.087-0.083		X
377444	2.43-2.33	0.096-0.092	X	X
386841	2.89-2.79	0.114-0.110	X	
386842	3.35-3.25	0.132-0.128	X	

CHECKS AND ADJUSTMENTS

Operation	Specification
Transmission End Play	0.203-1.117 mm. (0.008-0.044 inch) (Selective Thrust Washers Available)
Torque Converter End Play	New or rebuilt 0.533 mm. (0.021 inch) max. Used 1.016 mm. (0.040 inch) max. ①
Intermediate Band Adjustment	Remove and discard locknut. Install new locknut. Adjust screw to 14 N·m (10 ft-lbs) torque, then back off 1-1/2 turns. Hold screw and tighten locknut to 54 N·m (40 ft-lbs)
Forward Clutch Pressure Plate-to-Snap Ring Clearance	0.533-1.168 mm. (0.021-0.046 inch)
VRV to Transmission Vacuum Diaphragm — 6.9L Diesel	6.9 In Hg Vacuum with gauge block in place. See adjustment procedure.

Operation	Specification
Selection Snap Ring Thickness	1.42-1.52 mm. (0.056-0.060 inch)
	1.62-1.75 mm. (0.064-0.069 inch)
	1.87-1.98 mm. (0.074-0.078 inch)
	2.10-2.20 mm. (0.083-0.087 inch)
	2.33-2.43 mm. (0.092-0.096 inch)
Reverse-High Clutch Pressure Plate-to-Snap Ring Clearance	0.558-0.914 mm. (0.022-0.036 inch)
Selective Snap Ring Thickness	1.42-1.52 mm. (0.056-0.060 inch)
	1.62-1.75 mm. (0.064-0.069 inch)
	1.87-1.98 mm. (0.074-0.078 inch)
	2.10-2.20 mm. (0.083-0.087 inch)

① To check end play, exert force on checking tool to compress turbine to cover thrust washer wear plate. Set indicator at zero.



Technical Service Information

TORQUE LIMITS

Item	(ft-lbs)	N·m	Item	(ft-lbs)	N·m
Converter to Flywheel	20-34	28-45	Converter Drain Plug	8-28	11-37
Front Pump to Transmission Case	16-30	22-40	Manual Valve Inner Lever to Shaft	30-40	41-54
Overrunning Clutch Race to Case	18-25	25-33	Downshift Lever to Shaft	12-16	17-21
Oil Pan to Case	8-12	11-16	Filler Tube to Engine (Econoline-5.0L/5.8L/7.5L)	40-50	54-67
Stator Support to Pump	12-16	17-21	Filler Tube to Engine (Econoline 4.9L)	33-42	44-56
Converter Cover to Converter Housing	12-16	17-21	Filler Tube to Engine (Econoline 6.9L)	24-35	32-47
Guide Plate to Case	12-16	17-21	Transmission to Engine (Diesel Only)	50-65	67-87
Intermediate Servo Cover to Case	14-20	19-27	Transmission to Engine (All Gasoline Engines)	40-50	55-67
Diaphragm Assy. to Case	12-16	17-21	Rear Engine Support to Transmission	60-80	80-107
Distributor Sleeve to Case	12-16	17-21	Plug Case — Throttle Pressure	6-12	8.5-16
Extension Assy. to Transmission Case	25-35	34-47	5/16" Fitting — Cooler Line Connector to Case — Front and Rear (Case Fitting)	18-23	25-32
Plug — Case Front Pump or Line Pressure	6-12	8.5-16	5/16" Tube Nut — Cooler Line to Trans. Case Fitting	12-18	17-24
Pressure Gauge Tap	6-12	8.5-16			
Band Adj. Screw Locknut to Case	35-45	48-61			
	(in-lb)	N·m		(in-lb)	N·m
End Plates to Body	20-45	2.5-5	Reinforcing Right Side Plate to Lower Body	20-45	2.5-5
End Plates to Body	20-40	2.5-4.5	Converter Hsg. Cover to Converter Hsg. (7.5L)	30-60	3.5-6.5
Inner Downshift Lever Stop	20-45	2.5-5	Control Assy. to Case	95-125	11-14
Reinforcement Plate to Body	20-45	2.5-5	Gov. Body to Collector Body	90-120	10.5-13.5
Screen and Lower to Upper Valve Body	40-55	5-6.2	Detent Spring to Case	80-120	9.5-13.5
Shift Valve Plate to Upper Body	20-45	2.5-5	Rear Engine Support to Frame	40-60	5-6.5
Upper to Lower Body	40-55	5-6.2	Neutral Switch to Case	55-75	6.5-8
VRV to Fuel Injector Pump	75-90	8-10.5			

CD4721-2B

CLUTCH AND BAND APPLICATION CHART

	Forward Clutch	One Way Clutch	Low Reverse Clutch	Intermediate Band	Reverse High Clutch
1st Gear — Manual Low	Applied		Applied		
1st Gear — D	Applied	Holding			
2nd Gear — D	Applied			Applied	
3rd Gear — D	Applied				Applied
Reverse (R)			Applied		Applied



General Automatic Transmission Service

VEHICLE APPLICATION

Applies to all E-150—E-350, F-150—F-350 (4x2) (4x4) and Bronco Vehicles equipped with C6 and AOD Automatic Transmissions.

GENERAL INFORMATION

All automatic transmissions are equipped with high temperature resistant seals. This includes those seals used on the manual and kickdown levers, the O-rings and oil pan gasket. Under no conditions should older design seals be used on the transmissions, except the regular service replacement oil pan gasket, which is of special leak prevention design. This should still be used.

Transmission Identification

All vehicles are equipped with a Vehicle Safety Certification Label affixed to the left (driver's) side door lock post. Refer to the stamped code in the space marked "Trans." and to Fig. 1 below for proper transmission identification.

DIAGNOSIS AND TESTING

Troubleshooting the automatic transmission is simplified by using the proven methods of diagnosis. One of the most important things to remember is that there is a definite procedure to follow. Do not try to short cut or take it for granted that someone else has done the critical checks or adjustments.

The following procedures are recommended for checking and/or verifying that the various components are adjusted and operating properly. If an Automatic Transmission Tester is used, Rotunda model 014-00737 or equivalent, follow the manufacturer's instructions.

Linkage Check

Accelerator Linkage and Operation

The linkage must be free and must return to idle when released.

MFD. BY FORD MOTOR CO. IN U.S.A.							
DATE:	GVWR:		REAR GAWR:				
FRONT GAWR:	WITH		TIRES		WITH		
	TIRES		RIMS		TIRES		
	RIMS		AT PSI COLD		RIMS		
AT PSI COLD	AT PSI COLD						
THIS VEHICLE CONFORMS TO ALL APPLICABLE FEDERAL MOTOR VEHICLE SAFETY STANDARDS IN EFFECT ON THE DATE OF MANUFACTURE SHOWN ABOVE							
VEHICLE IDENTIFICATION NO.							
TYPE							
EXTERIOR PAINT COLORS						DSO	
WB	TYPE	GVW	BODY	TRANS	AXLE	TAPE	SPRING
				K			
↑							
TRANSMISSION CODE							

FIG. 1 Typical Vehicle Safety Standard Certification Label—Transmission Identification

Kickdown Linkage—C6 Transmission

Check for wide-open carburetor and linkage travel at full throttle. The carburetor full-throttle stop must be contacted by the throttle linkage and there must be a slight amount of movement left in the downshift linkage. Be sure the downshift linkage return spring is connected and the downshift lever returns to a closed position.

Throttle Valve Control Cable System Check—AOD

4.9L (300 CID) I-6 and 5.0L EFI Engine Application

Check for free cable and lever travel and return between idle and wide open throttle. Cable must not be loose where it fastens to the throttle body lever.

CAUTION: Do not drive vehicle if cable is broken or disconnected at carburetor.

Damage to friction elements in the transmission may result due to excessive slipping since TV (Throttle Valve) pressure will remain near zero. If it is necessary



Technical Service Information

to drive truck before repairing or resetting cable, disconnect cable at the transmission lever. TV pressure will now be near maximum allowing light throttle operation. However, shifts will be delayed and harsh.

Manual Linkage

This is a CRITICAL adjustment. Be sure the "D" (C6) or Ⓣ (AOD) detent in the transmission corresponds exactly with the stop in the steering column or console. Hydraulic leakage at the manual valve can cause delay in engagements and/or slipping while operating if the linkage is not correctly adjusted.

Transmission Fluid Level Check

CAUTION: Vehicle should not be driven if fluid level is below the "DO NOT DRIVE" hole.

Transmission—Operating Temperature

The automatic transmission should be checked at an operating temperature of 66 degrees to 77 degrees C (150 degrees to 170 degrees F) (dipstick is hot to the touch). The operating temperature may be obtained by driving 24-32 km (15 to 20 miles) of city-type driving with the outside temperature above 10 degrees C (50 degrees F).

CAUTION: If vehicle has been operated for an extended period at high speed, or in city traffic in hot weather, or vehicle is being used to pull a trailer, to obtain an accurate reading, the fluid has to cool, usually about 30 minutes after engine has been turned off.

Transmission—Room Temperature

If the transmission is not at an operating temperature of 66 degrees to 77 degrees C (150 degrees to 170 degrees F) and it becomes necessary to check the fluid level (such as pre-delivery), the fluid may be checked at room temperature, 21 degrees to 35 degrees C (70 degrees to 95 degrees F) (dipstick cool to touch).

Dipstick Reading

Refer to Fig. 2.

The fluid level on the dipstick should be within the cross hatched area at operating temperature. The fluid level on the dipstick should read between the holes at room temperatures.

Check the fluid as follows:

NOTE: It may be necessary to remove the air inlet tube located directly in the way of access to the dipstick.

1. With the transmission in PARK, engine at idle rpm, foot brakes applied, and vehicle on level surface, move the transmission selector lever through each range, allowing time in each range to engage transmission. Return to PARK, applying parking brake fully, and block the wheels. Do not turn off the engine during the fluid level check.
2. Clean all dirt from the transmission fluid dipstick cap before removing the dipstick from the filler tube.
3. Pull the dipstick out of the tube, wipe it clean, and push it all the way back into the tube. Be sure it is fully seated.

4. Pull the dipstick out of the filler tube again, and check the fluid level.

IMPORTANT: The fluid level indication on the dipstick will be different at operating temperature and room temperature. For the correct fluid level reading on the dipstick, follow the appropriate instructions stated previously.

Before adding fluid, be sure that the correct type will be used. If in doubt, check the Vehicle Certification Label affixed to the left front door lock face panel or door pillar for the Transmission/Transaxle Code. Also, the fluid is stamped on the dipstick.

CAUTION: Use of a fluid other than specified could result in transmission malfunction and/or failure.

If necessary, add enough fluid through the filler tube to raise the level to the correct position. Do not overfill the transmission, because it will result in foaming, loss of fluid through the vent, and possible transmission malfunction. If overfill occurs, excess must be removed.

5. Install the dipstick, making sure it is fully seated in the tube.

If the transmission fluid level is correctly established at 21 degrees to 35 degrees C (70 degrees to 95 degrees F), it will appear in the cross hatch area on the dipstick when the transmission reaches an operating temperature of 66 degrees to 77 degrees C (150 degrees to 170 degrees F). Do not overfill or underfill.

Overfill can cause the fluid to foam and spill out through the transmission vent resulting in a transmission malfunction.

Underfill can result in transmission loss of engagement or slipping. This condition is most evident in cold weather or when the vehicle is parked or being driven on a hill.

If the transmission fluid level is checked when the fluid is at room temperature, the dipstick could indicate that fluid should be added if the dipstick is misread. If fluid is added at this time, an overfill condition could result when the fluid reaches operating temperatures of 66 degrees to 77 degrees C (150 degrees to 170 degrees F) (dipstick hot to touch).

Refer to the specifications at the end of this Section for automatic transmission fluid requirements and capacities.

Transmission Fluid Condition Check

1. Make the normal fluid check according to the above procedure.

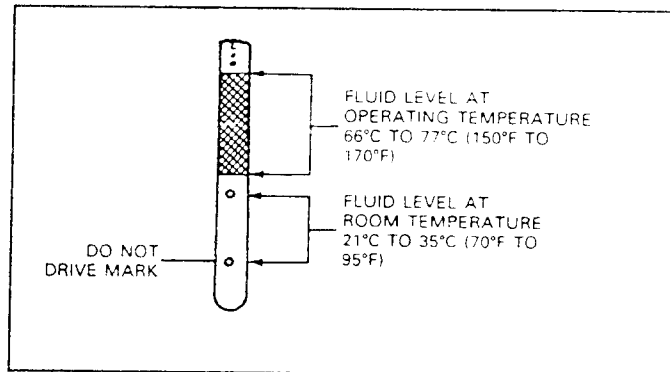

FIG. 2. Dipstick Reading—AOD, C6



2. Observe color and odor of the fluid. It should be dark reddish not brown or black. A burnt odor can sometimes indicate that there is an overheating condition or clutch disc or band failure.
3. Use an absorbent white facial tissue paper to wipe the dipstick. Examine the stain for evidence of solids (specks of any kind) and for antifreeze signs (gum or varnish on dipstick).

NOTE: Fluid used with the automatic transmission contains a detergent which retains in suspension particles generated during normal transmission use. This characteristic may result in a dark coloring of the fluid and does not by itself indicate malfunction or need for repair.

If specks are present in the oil or there is evidence of antifreeze, the transmission oil pan must be removed for further inspection. If fluid contamination or transmission failure is confirmed by further evidence of coolant or excessive solids in the oil pan, the transmission must be disassembled and completely cleaned and repaired. This includes cleaning the torque converter and transmission cooling system. It would be a waste of time to perform any further checks before cleaning and repairing the transmission.

During disassembly and assembly, all overhaul checks and adjustments of clearances and end play must be made.

High or Low Fluid Level

A fluid level that is too high will cause the fluid to become aerated. Aerated fluid will cause low control pressure, and the aerated fluid may be forced out the vent.

A fluid level that is too low can affect the operation of the transmission. Low level may indicate fluid leaks that could cause transmission damage.

Fluid Level High Before Starting Engine—OK During Normal Check

1. Check for correct operation of drainback valve in stator support.
2. Check pump bushing.
3. Replace or repair pump if required.

Transmission Fluid Cooler Flow Check

The linkage, fluid level and control pressure must be within specifications before performing this flow check.

Remove the transmission dipstick from the filler tube. Place a funnel in the transmission filler tube. Raise the vehicle, remove the cooler return line from its fitting in the case. Attach a hose to the cooler return line and fasten the free end of the hose in the funnel installed in the filler tube.

Start the engine and set idle speed at 1000 rpm with the transmission in neutral.

Observe the fluid flow at the funnel. When the flow is "solid" (air bleeding has been completed), the flow should be liberal. If there is not a liberal flow at 1000 rpm in neutral, low pump capacity, main circuit system leakage, or cooler system restriction is indicated.

Check both metal cooler lines between the transmission and radiator for restrictions. Check for restrictions in the metal or rubber cooler lines to and from the auxiliary cooler, if the vehicle is so equipped. Visually check and physically feel all bends for kinks, especially rubber cooler lines, that would restrict flow and could result in transmission overheating or lack of lubrication.

To separate transmission trouble from cooler system trouble, observe the flow at the transmission case converter-out fitting.

Transmission Fluid Leakage Checks

Check the speedometer cable connection at the transmission. Replace the rubber seal if necessary (if so equipped).

Leakage at the oil pan gasket often can be stopped by tightening the attaching bolts to the proper torque. If necessary, replace the gasket.

Check the fluid filler tube connection at the transmission case. If leakage is found, install a new O-ring. The filler tube brackets should align properly and be attached to the transmission or engine locations.

Check the fluid lines and fittings between the transmission and the cooler in the radiator tank for looseness, wear, or damage. If leakage is found, tighten the fitting, or replace the damaged parts (Fig. 3).

Check the engine coolant in the radiator. If transmission fluid is present in the coolant, the cooler in the radiator is probably leaking.

The cooler can be further checked for leaks by disconnecting the lines from the cooler fittings and applying 345-517 kPa (50-75 psi) air pressure to the fittings. Remove the radiator cap to relieve the pressure build up at the exterior of the oil cooler tank. If the cooler is leaking and/or will not hold pressure, the cooler must be replaced. Cooler replacement is described in the Cooling System Section of Group 27.

If leakage is found at either the downshift control lever shaft or the manual lever shaft, replace either or both seals.

Inspect the pipe plug on the left front side of the transmission case. If the plug shows leakage, tighten the plug to specifications. If leakage continues, replace the plug. On a C6 transmission, inspect the TV pressure plug on the right rear side of the case. On the AOD transmission, inspect the TV pressure plug, forward clutch, pressure plug and direct clutch on the right side of the case and tighten to specification if leakage is

Transmission	Radiator		Transmission		Fluid Line Nut	
	ft-lbs	N-m	ft-lbs	N-m	ft-lbs	N-m
AOD	8-12	11-16	18-23	24-31	12-18	17-24
C6	8-12	11-16	18-23	24-31	12-18	17-24

FIG. 3 Cooler Line Fitting Torque Specifications

evident. If the plug shows leakage, coat the threads with Motorcraft Sealing Compound or equivalent and tighten the plug to specification as listed at the end of the appropriate transmission Section. If leakage continues, replace the plug.

When a converter drain plug leaks, remove the drain plug with a six-point wrench. Coat the threads with Motorcraft Sealing Compound or equivalent and install the plug. Tighten the drain plug to specification as listed at the end of this Section. **Fluid leakage from the converter housing may also be caused by engine oil leaking past the rear main bearing, or from oil galley plugs, or power steering oil leakage from steering system. Be sure to determine the exact cause of the leak before starting repair procedures.**

Oil-soluble aniline or fluorescent dyes premixed at the rate of 1/2 teaspoon of dye powder to 0.23 liter (1/2 pint) of transmission fluid have proved helpful in locating the source of fluid leakage. Such dyes may be used to determine whether an engine oil or transmission fluid leak is present, or if the fluid in the oil cooler leaks into the engine coolant system. A black light must be used with the fluorescent dye solution.

Fluid Leakage in Converter Area

In diagnosing and correcting fluid leaks in the front pump and converter area, use the following procedures to locate the exact cause of the leakage. Leakage at the front of transmission, is evidenced by fluid around the converter housing, may have several sources. By careful observation, it is possible in many instances, to pinpoint the source of the leak before removing the transmission from the vehicle. The paths which the fluid takes to reach the bottom of the converter housing are shown in (Fig. 4).

1. Fluid leaking by the front pump seal lip will tend to move along the drive hub and onto the back of the impeller housing. Except in the case of a total seal failure, fluid leakage by the lip of the seal will be deposited on the inside of the converter housing only, near the outside diameter of the housing.
2. Fluid leakage by the outside diameter of the seal and front pump body will follow the same path which the leaks by the front pump seal follow.
3. Fluid that leaks by a front pump-to-case bolt will be deposited on the inside of the converter housing only. Fluid will not be deposited on the back of the converter.
4. Leakage by the front pump-to-case gasket may cause fluid to be deposited inside the converter housing, or it may seep down between the front of the case and converter housing.
5. Fluid leakage from the converter drain plugs or converter-to-flywheel stud weld will appear at the outside diameter of the converter on the back face of the flywheel, and in the converter housing only near the flywheel.

Engine oil leaks are sometimes improperly diagnosed as transmission front pump seal leaks. The following areas of possible leakage should also be checked to determine if engine oil leakage is causing the problem:

- a. Leakage at the rocker arm cover (valley cover) may allow oil to flow over the converter housing or seep down between the converter housing and cylinder block, causing oil to be present in or at the bottom of the converter housing.
- b. Oil galley plug leaks will allow oil to flow down the rear face of the block to the bottom of the converter housing

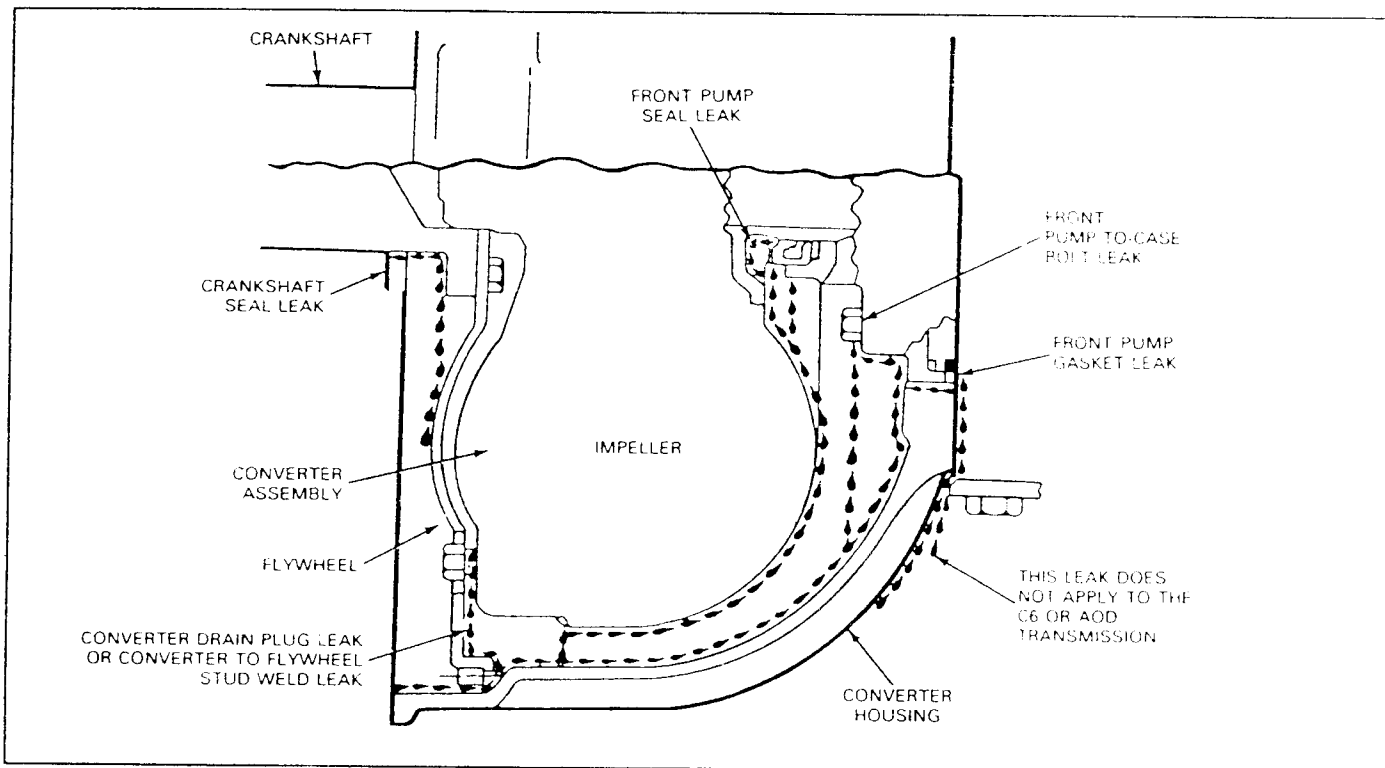

FIG. 4 Converter Leakage—Fluid Path

- c. Leakage by the crankshaft seal will work back to the flywheel, and then into the converter housing.

Fluid leakage from other areas, such as the power steering system forward of the transmission, could cause fluid to be present around the converter housing due to blow back or road draft. The following procedures should be used to determine the cause of the leakage before any repairs are made.

- a. Remove the transmission dipstick and note the color of the fluid. Original factory-fill fluid is dyed red, to aid in determining if leakage is from the engine or transmission. Unless a considerable amount of makeup fluid has been added or the fluid has been changed, the color should assist in pinpointing the leak. Since road draft may cause leaking power steering fluid to be present on the transmission, this leakage, if present, should be eliminated before checking the transmission for fluid leakage.
- b. Remove the converter housing cover. Clean off any fluid from the top and bottom of the converter housing, front of the transmission case, and rear face of the engine and engine oil pan. Clean the converter area by washing with a suitable non-flammable solvent, and blow dry with compressed air.
- c. Wash out the converter housing, the front of the flywheel, and the converter drain plugs. The converter housing may be washed out using cleaning solvent and a squirt-type oil can. Blow all washed areas dry with compressed air.
- d. Start and run the engine until the transmission reaches its normal operating temperature. Observe the back of the block and top of the converter housing for evidence of fluid leakage. Raise the vehicle on a hoist and run the engine at fast idle, then at engine idle, occasionally shifting to the drive and reverse ranges to increase pressure within the transmission. Observe the front of the flywheel, back of the block (in as far as possible), and inside the converter housing and front of the transmission case. Run the engine until fluid leakage is evident and the probable source of leakage can be determined.

Converter Leakage Check

If welds on the torque converter indicate leakage, remove the converter and make the following check.

Assemble a Rotunda 021-00054 Torque Converter Leak Detector or an equivalent to the converter. Test the converter for leaks following the directions supplied with the detector kit.

Engine Idle Speed Check (With the Throttle Positioner Application)

On vehicles that have curb idle speed adjustment capability, if the idle speed is too low, the engine will run roughly. An idle speed that is too high will cause the vehicle to creep, have harsh engagements and harsh closed-throttle downshifts.

Refer to the ENGINE/EMISSION DIAGNOSIS* manual for curb idle speed adjustment information.

On vehicles equipped with an Exhaust Gas Recirculation (EGR) system, it is important to check the system for proper operation and for a no restricted or leakage condition.

Control Pressure Test

C6

There are two methods of performing the control pressure test. One is to perform the test using the engine vacuum. The second method is to use a remote vacuum source such as the one provided in the distributor tester or a hand operated vacuum pump.

Engine Vacuum Pressure

When the vacuum diaphragm unit is operating properly and the manual and downshift linkage is adjusted properly, all the transmission shifts (automatic and kickdown) should occur within the road speed limits listed in the Technical Service Bulletin—Special Specifications Issue.

If the shifts do not occur within limits, or the transmission slips during shift point, use the following procedure to determine whether the engine, transmission, linkage, vacuum diaphragm unit or valve body is causing the condition. See page 6 for 7.3L Diesel C6 application for (VRV) Vacuum Regulator Valve.

1. Attach a tachometer to the engine and a vacuum gauge, Rotunda Number 059-00008, or equivalent to the transmission vacuum line at the manifold vacuum port (Fig. 5).
 2. Attach a pressure gauge to the control pressure outlet at the transmission (Fig. 6).
- CAUTION: Pressure gauges affect the shift quality of the transmission. Care should be taken NOT to accelerate or decelerate rapidly. Possible transmission failure could result.**
3. Firmly apply the parking brake and start the engine.
 4. Adjust the engine idle speed to the specified rpm, using the carburetor idle adjustment screw. If the

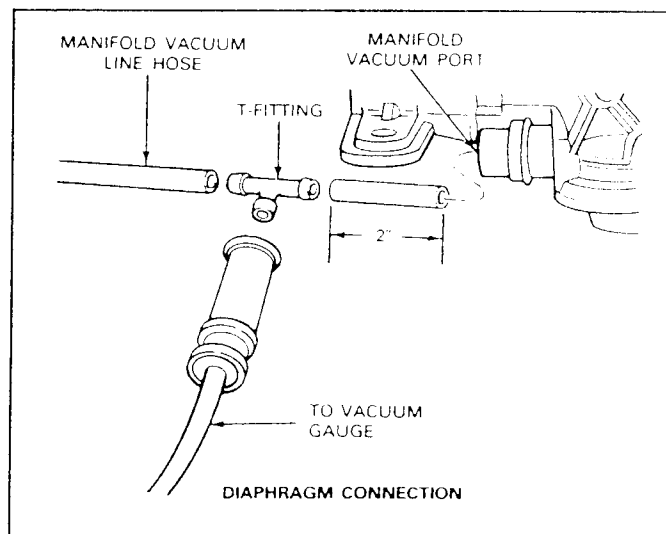

FIG. 5 Typical Vacuum Test Line Connections

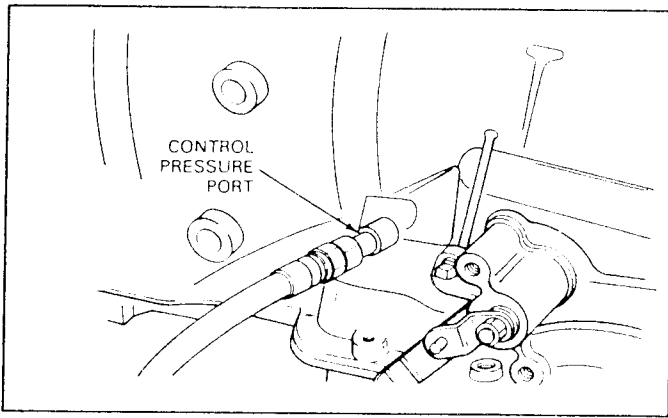

FIG. 6 Control Pressure Connecting Point—C6 Transmissions

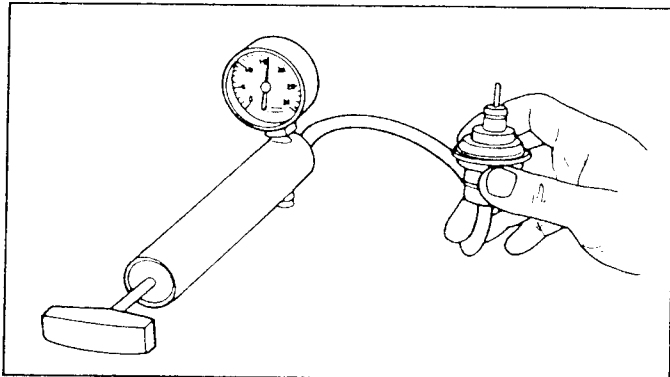

FIG. 7 Testing Transmission Vacuum Unit for Leakage

engine idle speed cannot be brought within limits, check the throttle and downshift linkage for a binding condition. If linkage is satisfactory, check for vacuum leaks in the transmission diaphragm unit (Fig. 7) and its connecting tubes and hoses. Check all other vacuum operated units (such as the power brake) for vacuum leaks.

Refer to the two control pressure diagnostic guides in Fig. 8 to show what components are inoperative when the control pressure test is not within specifications. Do not proceed with the main diagnosis guide until you have made any repairs, as required, and the control pressure is within specifications as listed in the Technical Service Bulletin—Special Specifications Issue.

Vacuum Pump Method

C6

Disconnect and temporarily plug the vacuum line at the vacuum diaphragm unit. Attach a vacuum pump to the vacuum diaphragm. Apply both the parking and service brakes. Start the engine and vacuum pump. Set the vacuum at 15 inches, read and record the control pressure in all selector positions. Run the engine up to 1000 rpm, and reduce the vacuum to 10 inches. Read and record the control pressure in D, 2 and 1. Keep the engine rpm at 1000 and reduce the vacuum to 1 inch. Read and record the control pressure in D, 1, 2 and R.

Refer to the two control pressure diagnostic guides in Fig. 8 to show what components are inoperative when the control pressure test is not within specifications. Do not proceed with the main diagnosis guide until you

have made any repairs, as required, and the control pressure is within specifications as listed in the Technical Service Bulletin—Special Specifications Issue.

Vacuum Supply Test

C6 (See Page 6 for 7.3L Diesel C6 Application for (VRV) Vacuum Regulator Valve)

The vacuum supply to the vacuum diaphragm unit and the diaphragm itself must be checked. To check the supply, disconnect the vacuum line at the diaphragm unit and connect it to a vacuum gauge. With the engine idling, the gauge must have a steady acceptable vacuum reading for the altitude at which the test is being performed. If the vacuum reading is low, check for a vacuum leak or poor engine vacuum. If the vacuum reading is OK, rapidly accelerate the engine momentarily. The vacuum reading must drop rapidly at acceleration and return immediately upon release of the accelerator. If the vacuum reading does not change or changes slowly, the transmission vacuum line is plugged, restricted or connected to a reservoir supply. Correct as required.

Vacuum Diaphragm Test—On Vehicle

C6

To check the vacuum diaphragm unit, start the vacuum pump and set the regulator knob so that the vacuum gauge reads 18 inches with the end of the vacuum hose blocked off. Then connect the vacuum hose to the diaphragm unit. If the gauge still reads 18 inches, the vacuum diaphragm unit is not leaking. If the reading does not remain at 18 inches, but drops, the vacuum diaphragm unit is leaking. Replace the vacuum diaphragm unit. Also, if automatic transmission fluid is present in the vacuum side of the diaphragm or in the vacuum hose, the diaphragm is leaking and must be replaced.

Vacuum Diaphragm Test—Off Vehicle

C6

To check the vacuum unit for diaphragm leakage, remove the unit from the transmission. Use a distributor tester equipped with a vacuum pump or Rotunda Vacuum Tester 021-00014 or equivalent (Fig. 7). Set the regulator knob until the vacuum gauge reads 18 inches with the end of the vacuum hose blocked off.

Connect the vacuum hose to the manifold vacuum port as shown in Fig. 7. If the gauge still reads 18 inches, the vacuum unit diaphragm is not leaking. A second leakage check can be made as the hose is removed from the transmission vacuum unit. Hold a finger over the end of the control rod. When the hose is removed, the internal spring of the vacuum unit should push the control rod outward. If the vacuum diaphragm needs replacing, install a new unit that has been released for service. Vacuum diaphragm assembly identification is given at end of this Section.

Control Pressure Test—AOD

Line pressure and throttle pressure on the Automatic Overdrive Transmission is tested in the idle position (zero T.V.) and wide-open-throttle position. Line pressure and throttle pressure specifications can be found in the Technical Service Bulletin—Special Specifications Issue. In each of the two modes the Reverse specifications will be higher than the others.

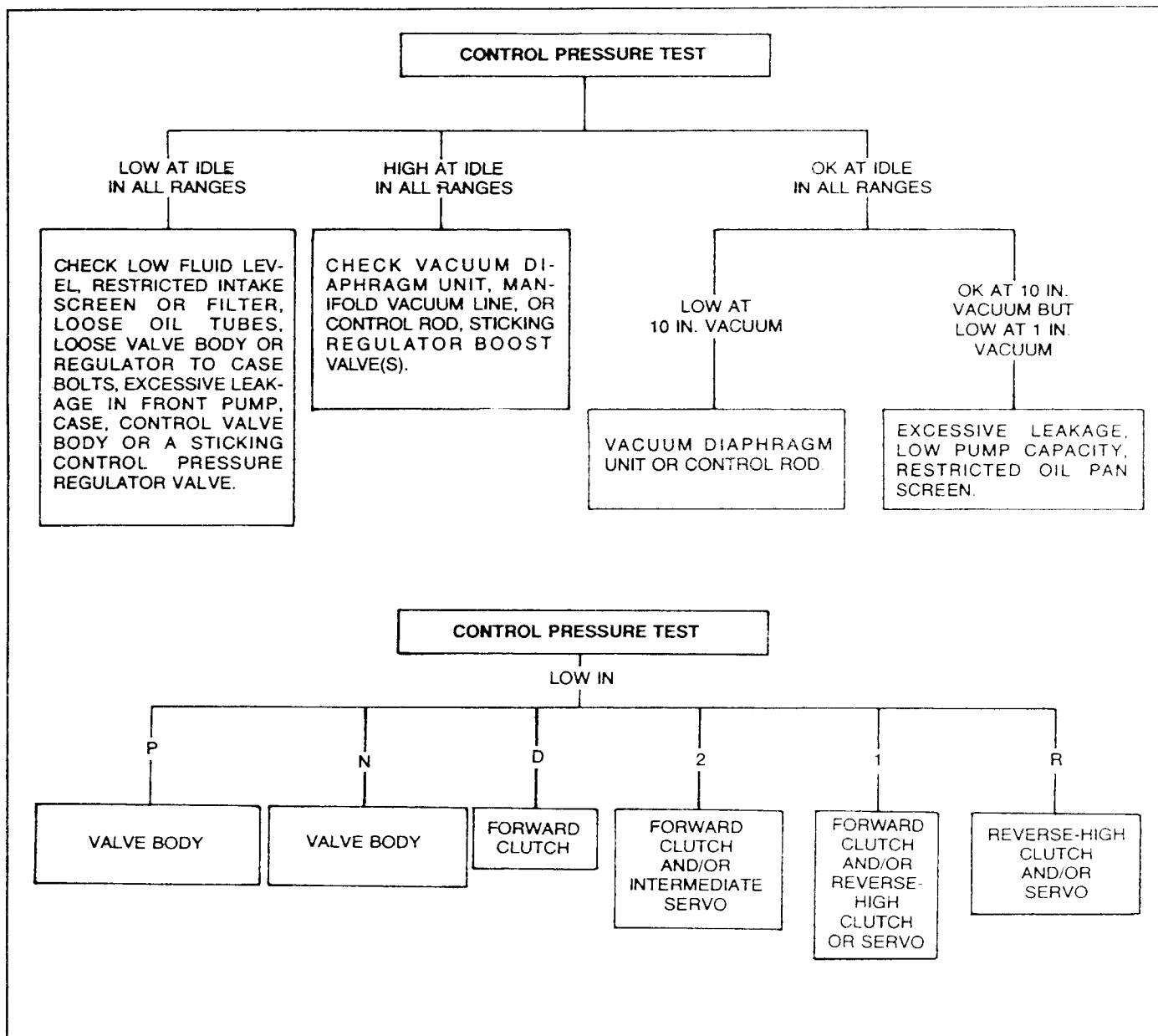

FIG. 8 Control Pressure Test Charts—C6

1. Be sure the T.V. linkage is properly adjusted.
2. Connect a 300 psi gauge to the line pressure port on the case left side just above the control lever (Fig. 9). Have sufficient flexible hose to make the gauge accessible while operating the engine.
3. Connect a 0-100 psi pressure gauge to the TV port on the right side of the case (see Fig. 9). Have sufficient flexible Hose to make the gauge accessible while operating the engine.

CAUTION: Pressure gauges affect the shift quality of the transmission. Care should be taken NOT to accelerate or decelerate rapidly. Possible transmission failure could result.

NOTE: W.O.T. readings are to be made at full stall. However, be sure to run the engine at fast idle in neutral for cooling between test.

4. Run the engine until it is hot.

CAUTION: Idle pressure must be read with the throttle off the fast idle cam.

5. Apply the service and parking brakes firmly and shift through all the ranges. Record the line pressure and the throttle pressure and compare it with specifications.

After making the control pressure tests, analyze the results to relate to the conditions in Figs. 10, 11 and 12.

Keep in mind that clutch and servo leakage may or may not show up on the control pressure test. This is because (1) the pump has a high output volume and the leak may not be severe enough to cause a pressure drop; and (2) orifices between the pump and pressure chamber may maintain pressure at the source, even with a leak downstream. Pressure loss caused by a less-than-major leak is more likely to show up at idle than at W.O.T. where the pump is delivering full volume.

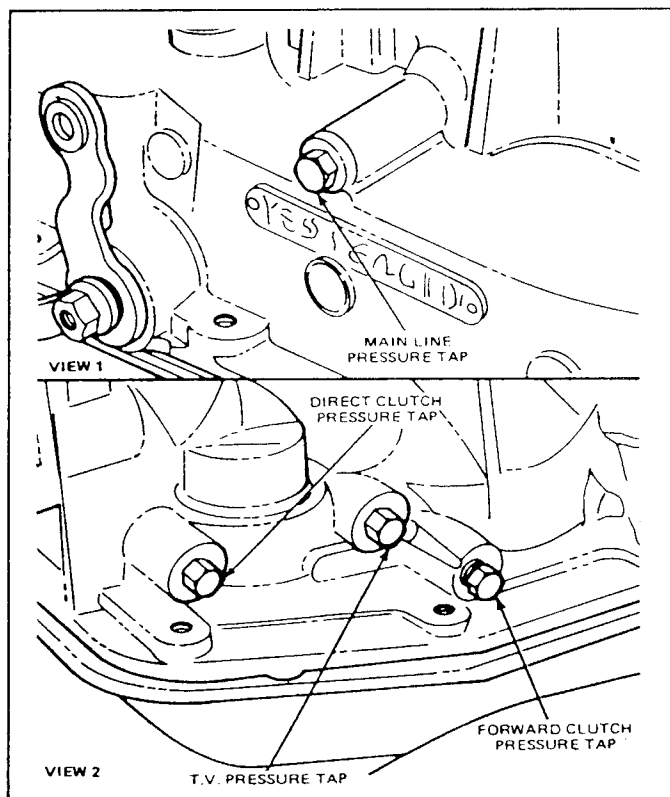

FIG. 9 Control Pressure Connecting Points—AOD

Conversely, if you are manipulating the T.V. linkage to simulate W.O.T., but actually testing at idle, the leak is more likely to cause a pressure loss in the W.O.T. position.

To further isolate leakage in a clutch or servo circuit, it is necessary to remove the oil pan and valve body, and to perform case air pressure tests.

Direct Clutch Pressure Test—AOD

The direct clutch pressure test outlined below will diagnose a low pressure condition or leakage in the direct clutch circuit. A difference of 15 psi or more between direct clutch pressure and line pressure (read at the forward clutch pressure tap) will prevent a 3-4 shift.

1. Attach 0-300 psi pressure gauges to the forward clutch pressure tap and to the direct clutch pressure tap (Fig. 9). Gauge accuracy must be capable of distinguishing a 15 psi difference. (If this test is done in conjunction with a control pressure test, pressure gauges will be attached to all pressure taps.) Have sufficient flexible hose to read the gauges in the vehicle.

CAUTION: Pressure gauges affect the shift quality of the transmission. Care should be taken not to accelerate or decelerate rapidly. Possible transmission failure could result.

2. Drive the vehicle. When pressure is applied to the direct clutch, note the difference between the line pressure read at forward clutch pressure tap and the direct clutch pressure.
3. If the difference in pressures is less than 15 psi, the direct clutch circuit is ok.
4. If the difference is greater than 15 psi, there could be a leak in the direct clutch pressure circuit. If the

difference does exceed 15 psi, the gauges on line pressure and direct clutch pressure can be switched to confirm that gage calibration difference is not the cause.

Stall Test

Refer to Fig. 13.

The stall test checks converter clutch operation and installation, the holding ability of the forward clutch, reverse clutch, the low-reverse bands, the planetary one-way clutch and engine performance.

The test should be done only with the engine coolant and transmission fluid at proper levels and at operating temperature, and with the TV linkage set properly.

Apply the service and parking brakes firmly for each stall test.

1. Find the specified stall RPM for the vehicle by referring to the Technical Service Bulletin—Special Specifications Issue. Use a grease pencil to mark the RPM on the dial of a tachometer.
2. Connect the tachometer to the engine.
3. In each of the following ranges for Automatic Overdrive (D, 1, R; for C6,—D, 2, 1, R; press the accelerator to the floor and hold it just long enough to let the engine get to full RPM. While making this test, do not hold the throttle open for more than five seconds at a time.
4. Note the results in each range.
5. After each range, move the selector lever to N (neutral) and run the engine at 1000 RPM for about 15 seconds to cool the converter before making the next test.
6. Refer to Fig. 13 for corrective actions.

IMPORTANT: If the engine speed recorded by the tachometer exceeds the maximum limits given in the Specifications, release the accelerator immediately because clutch or band slippage is indicated.

Governor Check

C6

The governor can be checked at the same time as the Control Pressure Test is performed and in the same manner.

Raise the vehicle with an axle or frame hoist so that the rear wheels are clear of the floor. Disconnect and plug the vacuum line to the vacuum diaphragm unit. Connect the line from the distributor tester if available to the vacuum diaphragm unit. Vacuum pump can be used with an extended vacuum hose to operate from within the vehicle.

CAUTION: Never exceed 96 km (60 mph) speedometer speed.

Place the transmission in D (DRIVE), no load on the engine and apply 10 inches of vacuum to the vacuum diaphragm unit. Increase the speed slowly and watch the speedometer. Check the mph at which the control pressure cutback occurs. It should occur between 16-32 km (10-20 mph).

NOTE: After each test, move the selector to N (neutral) and run the engine at 1000 RPM to cool the transmission.

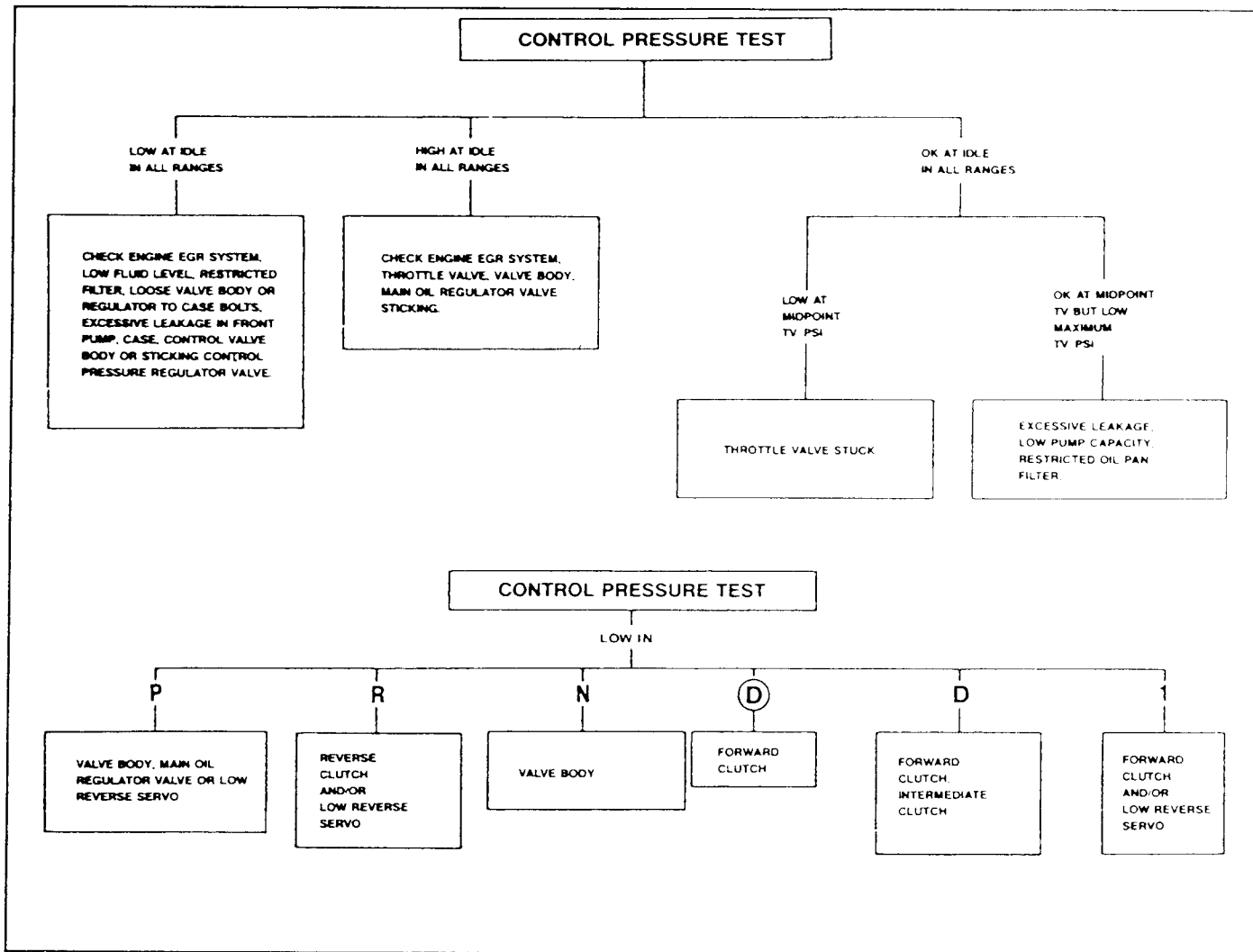

FIG. 10 Control Pressure Test Charts—AOD

The governor is good if the cutback occurs within these specifications. If the cutback does not occur within specifications, check shift speeds to verify that it is the governor and not a stuck cutback valve, then repair or replace the governor.

AOD

Perform a shift point check. (Road test or in shop). If the shift points are not within specifications, proceed with the following governor check. Accelerate vehicle to 40 km/h (25 mph) then back off throttle completely. The transmission should shift to third gear.

Shift Point Checks

Road Test

C6

This check will determine if the governor pressure and shift control valves are functioning properly.

Check the minimum throttle upshifts in D (DRIVE). The transmission should start in first gear, shift to second, and then shift to third, within the shift points listed in Technical Service Bulletin—Special Specifications Issue.

With the transmission in third gear, depress the accelerator pedal through the detent (to the floor). The

transmission should shift from third to second or third to first, depending on the vehicle speed.

Check the closed throttle downshift from third to first by coasting down from about 48 km (30 mph) in third gear. The shift should occur within the limits listed in the Specifications.

When the selector lever is at 2 (SECOND), the transmission can operate only in second gear.

With the transmission in third gear and road speed over 80 km (50 mph) the transmission should shift to second gear when the selector lever is moved from D (DRIVE) to 2 (SECOND) or 1 (FIRST).

The transmission will downshift from second or third to first gear when this same manual shift is made below approximately 48 km (30 mph) with a C6 transmission.

Refer to the band application chart in Fig. 14 to aid in diagnosis of transmission conditions.

In Shop

A shift test can be performed in the shop to check shift valve operation, governor circuits, shift delay pressures, throttle boost and downshift valve action.

Raise the vehicle with an axle or frame hoist so that the rear wheels are clear of the floor. Disconnect and plug the vacuum line to the vacuum diaphragm unit

Control Pressure Test Results:	
Control Pressure Condition	Possible Causes
Low in P	Valve body bolts loose, low reverse servo leakage.
Low in R	Reverse clutch leakage, low reverse servo leakage.
Low in N	Valve body bolts loose.
Low in \textcircled{D}	Forward clutch leakage, overdrive servo leakage, valve body bolts loose
Low in D	Forward clutch leakage.
Low in 1	Forward clutch leakage, low reverse servo leakage.
Low at idle in all ranges.	Low fluid level, restricted oil filter, loose valve body bolts, pump leakage, case leakage, valve body leakage, excessively low engine idle, fluid too hot, main oil regulator valve sticking
High at idle in all ranges.	T.V. linkage, valve body (throttle valve or main oil regulator valve sticking).
Okay at idle but low at W.O.T.	Internal leakage, pump leakage, restricted inlet screen, T.V. linkage, valve body (T.V. or T.V. limit valve sticking), main oil regulator valve sticking.

FIG. 11 Control Pressure Test Results Chart—AOD

T.V. Pressure	Line Pressure	Range	Possible Cause
High at WOT	High at WOT	All	TV limit valve not regulating pressure — repair or replace valve body.
Low at WOT	Low at WOT	All	Throttle valve stuck — repair or replace valve body TV linkage out of adjustment/damaged/binding — adjust and/or repair as necessary.

FIG. 12 TV Pressure and Line Pressure Test Results—AOD

(C6). Connect the line from the distributor tester vacuum pump to the vacuum diaphragm unit.

CAUTION: Never exceed 96 km (60 mph) speedometer speed.

1. To check the shift valves and governor circuits, apply 18 inches of vacuum to the transmission vacuum diaphragm unit. Place the transmission in Drive and make a minimum throttle 1-2 and 2-3 shift. At the shift points you will see the speedometer needle make a momentary surge and feel the driveline bump. If the shift points are within specification, the 1-2 and 2-3 shift valves and governor are OK.

If the shift points are not within specification, perform a Governor Check to isolate the problem.

NOTE: After each test, move the selector lever to Neutral, run the engine at 1000 rpm to cool the transmission.

2. To check the shift delay pressures and throttle boost, decrease the vacuum at the vacuum diaphragm to 0-2 inches. Make a 1-2 shift test. If the shift point raises to specification, the throttle boost and shift delay systems are functioning.
3. To check downshift valve action. Leave the vacuum to the vacuum diaphragm at 0-2 inches. Position the downshift linkage in the wide open throttle position (through the detent) and repeat the 1-2 shift test. The speed at the shift point should be higher.

Shift speed specifications can be found in the Technical Service Bulletin—Special Specifications Issue.

Shift Point Checks AOD

Road Test

This check will determine if the governor pressure and shift control valves are functioning properly. During

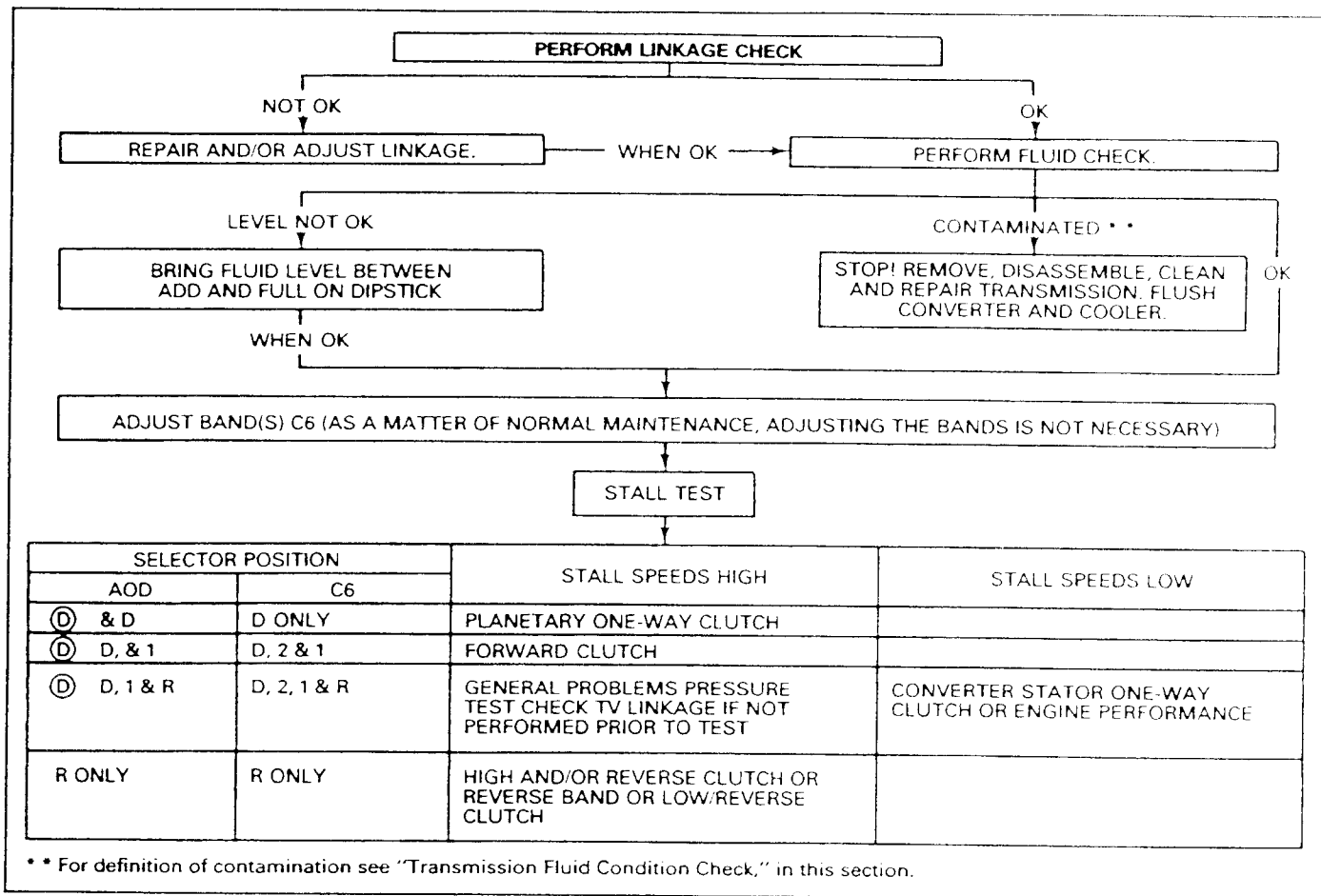

FIG. 13 Stall Diagnosis Test

the shift point check operation, if the transmission does not shift within specifications or certain gear ratios cannot be obtained, refer to the diagnosis wheel or to the symptom analysis Section of this book to resolve the problem.

Shift speed specifications can be found in the Technical Service Bulletin—Special Specifications Issue.

Choke on will effect shift points minimum throttle upshifts. Check minimum throttle upshifts in the fourth gear (overdrive). The transmission should start in first gear, shift to second gear then shift to third gear and finally shift to fourth gear, within the shift points specified in the shift speed specifications.

Forced Downshifts:

With the transmission in fourth gear (overdrive) depress the accelerator pedal to the floor. The transmission should downshift to third gear or to second gear, depending on vehicle road speed. Refer to the appropriate shift speed specifications.

Closed Throttle Downshifts

Closed throttle downshifts should be extremely difficult to detect. It may be necessary to attach pressure gauges to the forward and direct clutch pressure taps (Fig. 9) in order to detect 4-3 and 3-2 coast downshifts.

With gauges attached a 4-3 coast (closed throttle) downshift is signified by the application of the forward

clutch (the psi reading from the gauge on the forward clutch pressure tap will indicate an increase in pressure from 0 psi to 60 psi). A 3-2 coast downshift is signified by the release of the direct clutch (the psi reading from the gauge on the direct clutch pressure tap will indicate a decrease in pressure from 60 psi to 0 psi). A 2-1 coast downshift should be imperceptible. The coast downshifts should occur within the limits set forth in the shift speed specifications.

When the shift selector is in manual low (1) the transmission will not upshift from first gear.

When the shift selector is moved from either Ⓓ (overdrive) or direct drive (D) ranges to the manual low (1) position, the transmission will downshift into second gear if the vehicle is moving over (approximately) 41 km/h (25 mph) and into first gear if the vehicle is moving less than (approximately) 41 km/h (25 MPH).

The overdrive band is applied when the transmission is in manual second. The low-reverse band is applied when the transmission is in manual first gear.

The automatic overdrive transmission will not shift into fourth gear (overdrive) at wide open throttle.

The Automatic Overdrive Transmission will not make a 4-1 downshift.

When the vehicle road speed drops below approximately 58 km/h (35 mph), the transmission automatically downshifts from Ⓓ (overdrive) into third gear.

C6 AUTOMATIC TRANSMISSION CLUTCH AND BAND APPLICATION SUMMARY							
Gear	Holding Members	Front Planetary Gearset			Rear Planetary Gearset		
		Driven	Held	Output	Driven	Held	Output
Manual Low 1	Forward Clutch Low-and-Reverse Clutch	Ring Gear	*Carrier	Sun Gear	Sun Gear	Carrier	Ring Gear
D Low	Forward Clutch One-way Clutch	Ring Gear	*Carrier	Sun Gear	Sun Gear	Carrier	Ring Gear
*The carrier is actually turning with the output shaft, but at a slower speed than the input.							
D Second or 2	Forward Clutch & Band	Ring Gear	Sun Gear	Carrier	EFFECTIVELY IN NEUTRAL		
High	Forward Clutch Reverse-and-High Clutch	Sun Gear Ring Gear	None	Carrier	TURNS AS A UNIT		
Reverse	Reverse-and-High Clutch Low-and-Reverse Clutch	EFFECTIVELY IN NEUTRAL			Sun Gear	Carrier	Ring Gear

AOD AUTOMATIC TRANSMISSION CLUTCH AND BAND APPLICATION SUMMARY								
Gear	Intermediate Friction Clutch	Intermediate Roller Clutch	Overdrive Band	Reverse Clutch	Forward Clutch	Planetary (Low) One-Way Clutch	Low and Reverse Band	Direct Clutch
1 Range Low					Applied	Holding	Applied	
O/D and 3 Range Low					Applied	Holding		
Second (Intermediate)	Applied	Holding			Applied	Overruns		
Third (Direct)	Applied	Overruns			Applied	Overruns		Applied
Fourth (Overdrive)	Applied		Applied			Overruns		Applied
Reverse				Applied			Applied	

FIG. 14 Band Application Chart

In Shop

A shift test can be performed in the shop to check shift valve operation, governor circuits, shift delay pressures, throttle boost and downshift valve action.

Raise the vehicle with an axle or frame hoist so that the rear wheels are clear of the floor.

CAUTION: Never exceed 96 km/h (60mph) speedometer speed or rapidly apply the brakes to stop the rear wheels.

To check the shift valves and governor circuits, place the transmission in overdrive and make a minimum throttle 1-2, 2-3 and 3-4 shift test. When the shift occurs, you will see the speedometer needle make a momentary surge and feel the driveline bump. If the shift points are within specification, the 1-2, 2-3 and 3-4 shift valves and governor are OK.

If the shift points are not within specification, perform a Governor Check to isolate the problem.

Place the transmission in manual 2, no load on the engine and apply 10 inches of vacuum to the vacuum diaphragm unit. Increase the speed slowly and watch the speedometer. Check the mph at which the control pressure cutback occurs. It should occur between 16-32 km (10-20 mph).

NOTE: After each test, move the selector lever to N (Neutral) and run the engine at 1000 rpm to cool the transmission.

Decrease the vacuum at the vacuum diaphragm to 0.2 inches. Repeat the check. Control pressure cutback should occur between 48-80 km (30-50 mph).

The governor is good if the cutback occurs within these specifications. If the cutback does not occur within specifications, check shift speeds to verify that it is the governor and not a stuck cutback valve, then repair or replace the governor.

Shift speed specifications can be found in the Technical Service Bulletin—Special Specifications Issue.

Diagnosis Tips AOD Only

Some tips on diagnosing problems with specific components are:

INTERMEDIATE CLUTCH OR ONE-WAY CLUTCH—transmission shifts 1-3 or slips in second gear.

REVERSE CLUTCH—slip or no engagement in R. (Also can be caused by the low-reverse band or servo.)

FORWARD CLUTCH/PLANETARY LOW ONE-WAY CLUTCH—no engagement in forward ranges or slip in forward.

OVERDRIVE BAND OR SERVO—no fourth gear, slip in fourth gear, or no engine braking in second gear in range 1.

DIRECT CLUTCH—slip in third or fourth, or no upshift beyond second.

LOW-REVERSE BAND OR SERVO—no reverse or slip in reverse. Possibly no engine braking in manual low first gear, which would isolate the problem to the band rather than reverse clutch.

Accumulators

Leaking seals on the accumulator pistons can cause their respective clutches to slip. If the 2-3 accumulator seals leak, the symptoms could resemble a direct clutch or forward clutch problem. A leaking 3-4 accumulator will cause a harsh 3-4 upshift.

T.V. Pressure Low

Another reminder: if the shifts seem soft or mushy, do not make any heavy throttle tests. Check and adjust the T.V. linkage before making a complete road test.

Air Pressure Checks

C6

A NO DRIVE condition can exist, even with correct transmission fluid pressure, because of inoperative clutches or bands. On automatic transmissions, an erratic shift can be caused by a stuck governor valve. The inoperative units can be located through a series of checks by substituting air pressure for fluid pressure to determine the location of the malfunction.

When the selector lever is at 2 (second) a NO DRIVE condition may be caused by an inoperative forward clutch. A NO DRIVE condition at D (drive) may be caused by an inoperative forward clutch or one-way clutch. When there is no drive in 1 (low) the difficulty could be caused by improper functioning of the forward clutch or simultaneous malfunction of the low-reverse band and the one-way clutch. Failure to drive in R (Reverse) could be caused by a malfunction of the reverse-high clutch or low-reverse band or clutch.

When you have a slip problem but don't know whether it is in the valve body or in the hydraulic system beyond the valve body, the air pressure tests can be very valuable.

To make the air pressure checks, loosen the oil pan bolts and lower one edge to drain the transmission fluid. Remove the oil pan and the control valve body assembly. The inoperative clutches or bands can be located by introducing air pressure into the various transmission case passages (Figs. 15 and 16).

Forward Clutch

Apply air pressure to the transmission case forward clutch passages (Figs. 15 and 16). A dull thud can be heard when the clutch piston is applied. If no noise is heard, place the finger tips on the input shell and again apply air pressure to the forward or front clutch passage. Movement of the piston can be felt as the clutch is applied.

Governor

Apply air pressure to the control pressure to governor passage (Figs. 15 and 16) and listen for a sharp clicking or whistling noise. The noise indicates governor valve movement.

Reverse-High Clutch

Apply air pressure to the reverse-high clutch (Figs. 15 and 16). A dull thud indicates that the reverse-high or rear clutch piston has moved to the applied position. If no noise is heard, place the finger tips on the clutch drum and again apply air pressure to detect movement of the piston.

Intermediate Servo

Hold the air nozzle in the front servo apply tube or the intermediate servo apply passages (Figs. 15 and 16).

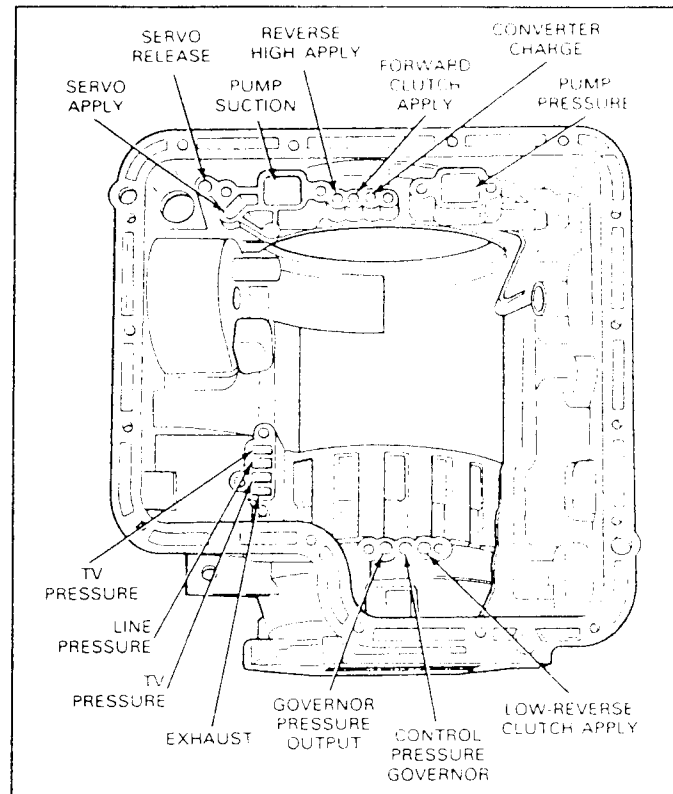

FIG. 15 Case Fluid Passage Hole Identification—C6 Automatic

Operation of the servo is indicated by a tightening of the front or intermediate band around the drum on C6 transmissions. Continue to apply air pressure to the servo apply tube or passage, and introduce air pressure into the front release tube or the intermediate servo release passage. The front or intermediate servo should release the band against the apply pressure.

Low-Reverse Clutch C6 Only

Apply air pressure to the low-reverse clutch apply passage (Fig. 15). A dull thud should be heard if the clutch is operating properly. If the passages are clear, remove the clutch assemblies, and clean and inspect the malfunctioning clutch to locate the trouble.

Air Pressure Checks AOD

A NO DRIVE condition can exist even with the correct transmission fluid pressure because of inoperative clutches or bands. The inoperative units can be located by substituting air pressure for fluid pressure through a series of passages to determine the location of the malfunction (Fig. 17).

A NO DRIVE condition in Ⓓ (overdrive) may be caused by an inoperative forward clutch or one-way clutch. When there is a NO DRIVE in 1st. (first), the difficulty could be caused by improper functioning of the forward clutch or low-reverse band and the one-way clutch.

Air pressure checks can also isolate slip problems as to whether the source of the problem is in the valve body or in the hydraulic system beyond the valve body.

The passages can be tested adequately with air pressure regulated at 40 psi. However, it may be necessary to use higher air pressure (90 psi) if there is difficulty in hearing the clutches apply.

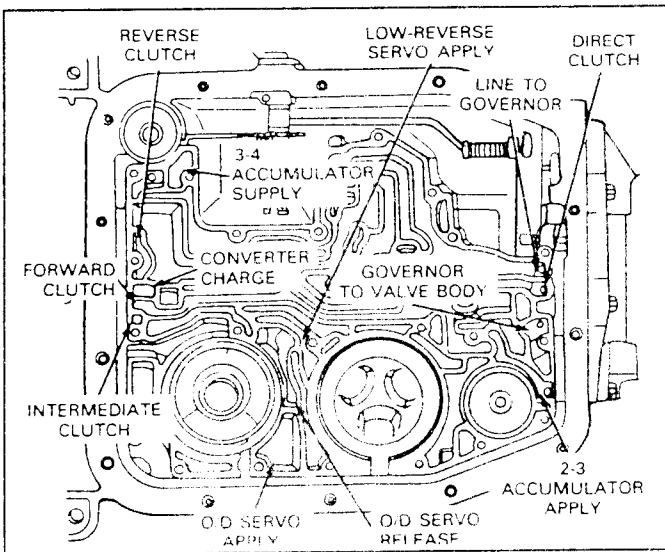

FIG. 16 Air Pressure Checks—Case Apply Passages—Automatic Overdrive Transmission (AOD)

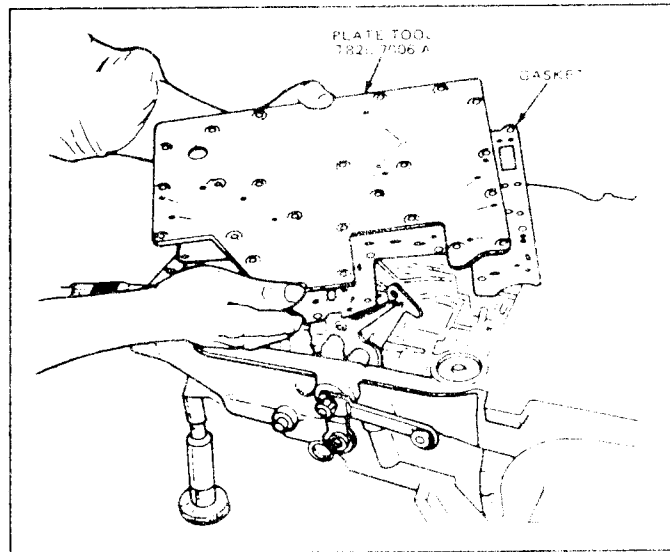

FIG. 18 Installing Air Pressure Plate Service Tool and Main Control Gasket—AOD

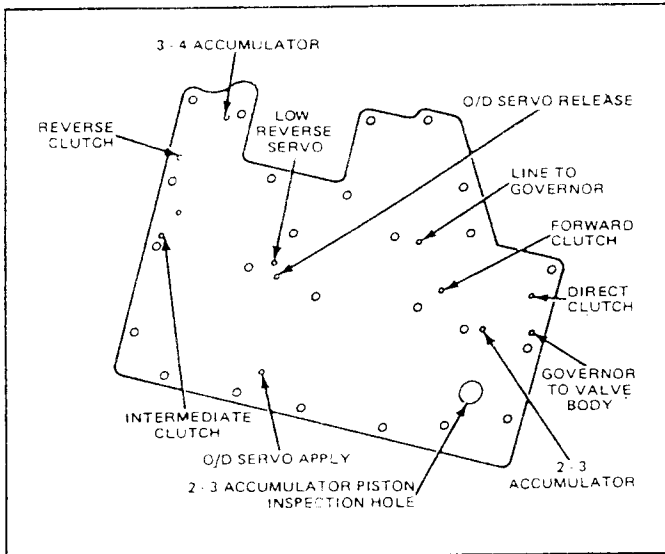

FIG. 17 Air Pressure Check Plate—AOD Transmission Service Tool T82L-7006-A

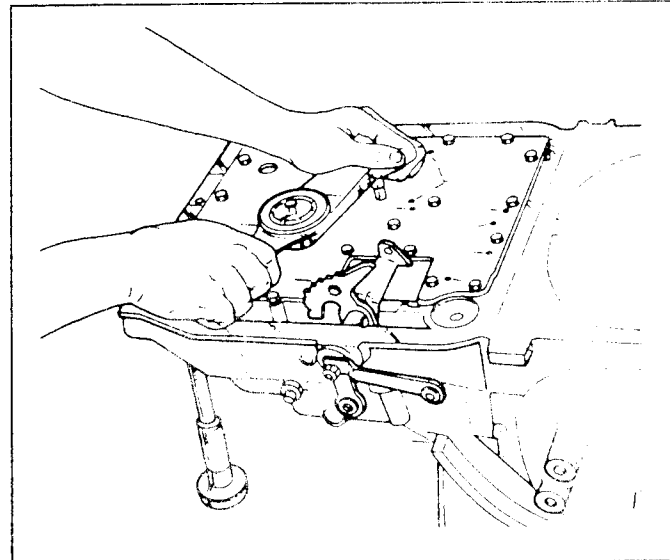

FIG. 19 Tighten T82P-7006-C Cap Screws—AOD

Use the main control gasket and service Tool T82L-7006-A with T82P-7006-C cap screws (M6 x 16) to seal the case apply passages (Figs. 17 and 18). Tighten the cap screws 9-11 N·m (80-100 in. lb.) (Fig. 19). Apply air to the apply passages in the service tool plate using the air nozzle service tool Tool-7000-DE with the rubber tip Tool-7000-DD or equivalent.

All locations of the case apply passages are stamped on the service tool plate. The transmission case apply holes are illustrated in Fig. 20.

Notes on Air Checks:

If the servos or the accumulators do not operate, disassemble, clean and inspect them to locate the source of the trouble. If air pressure applied to either of the clutch passages fails to operate a clutch or operates both clutches at once, remove and with air pressure, check the fluid passages in the case and front pump to detect obstructions.

Clutches—Reverse Clutch, Forward Clutch, Intermediate Clutch and Direct Clutch

Apply air pressure to the appropriate passage in the service tool (Fig. 17). A dull thud can be heard on the case as the clutch piston is applied (Fig. 21). Movement of the reverse clutch drum may also be detected when the reverse clutch passage is pressure tested (Fig. 21).

3-4 Accumulator

Apply air pressure to the 3-4 accumulator apply passage. The accumulator piston should unseat (Fig. 22).

2-3 Accumulator

Apply air pressure to the 2-3 accumulator apply passage. The accumulator piston should unseat. This can be detected by inserting a metal rod into the 2-3 piston hole. When the piston unseats the rod will move. Also, a thud can be heard when the piston applies (Fig. 23).

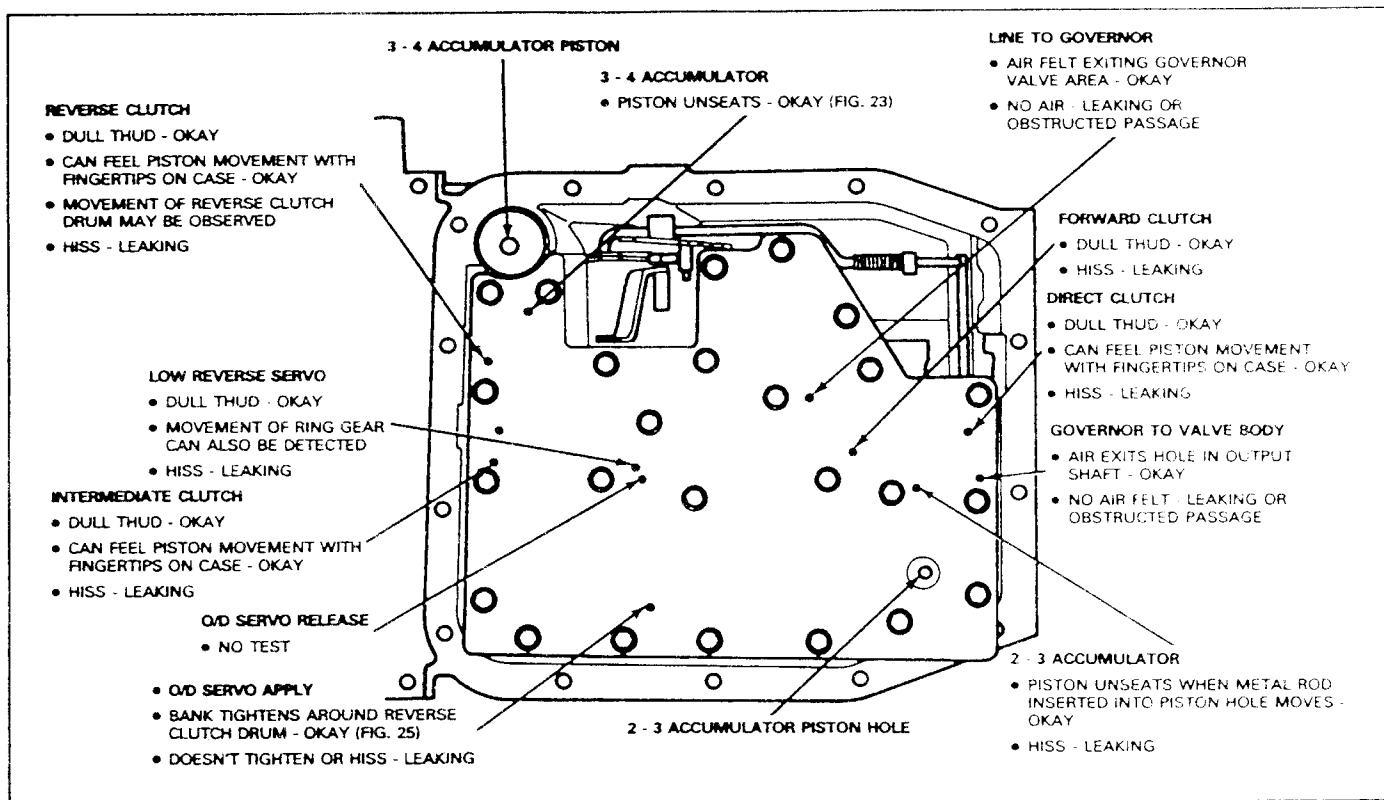

FIG. 20 Air Pressure Test—AOD

Overdrive Servo

Apply air pressure to the overdrive O/D servo apply passage in the service tool plate. Operation of the band is indicated by the tightening of the band around the reverse clutch drum (Fig. 24). The O/D servo will return to the release position as a result of spring force from the release spring. Also, when the servo returns to the release position, a thud can be felt on the O/D servo cover. The band will then relax.

Low-Reverse Servo

Apply air pressure to the low-reverse servo apply passage in the service tool plate. A dull thud can be

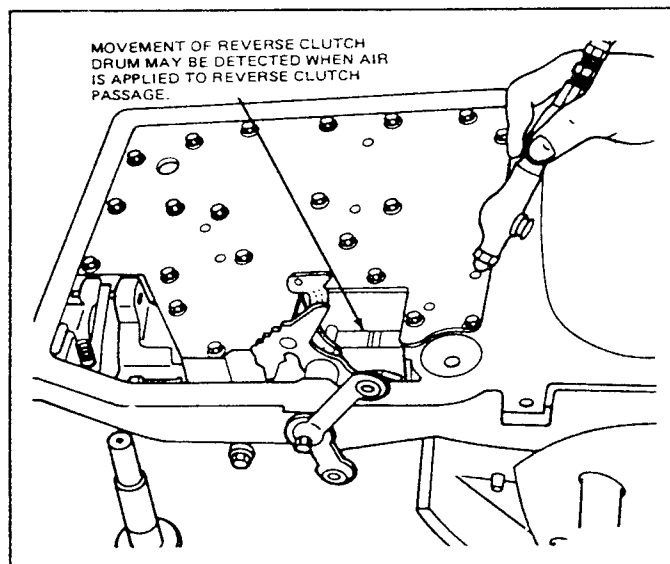

FIG. 21 Air Pressure Test—Reverse Clutch—AOD

heard when the low-reverse band tightens around the planetary assembly drum surface. Also, movement of the ring gear can be detected (Fig. 25).

Governor

Apply air pressure to the line to governor passage while holding finger near the governor valve (Fig. 26). If air is felt exiting the valve area, the passage is unobstructed.

To Air pressure check the governor to valve body passage, remove the governor. Apply air pressure to the passage while holding finger over holes in the output shaft (Fig. 27). If air exists in one of the holes, the passage is unobstructed.

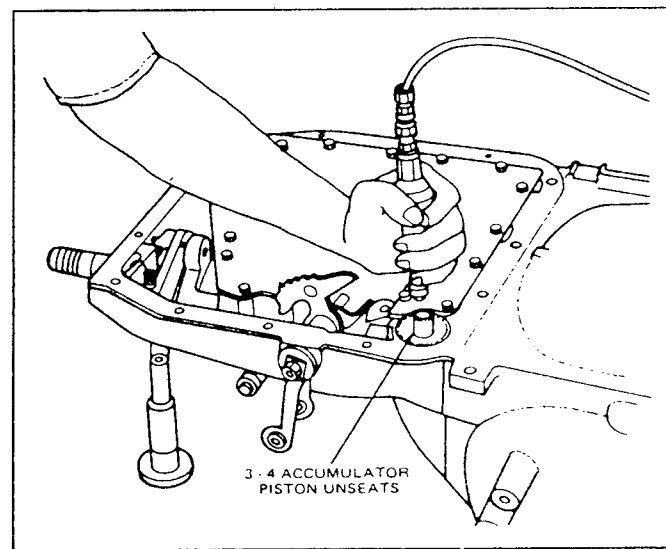

FIG. 22 Air Pressure Test—3-4 Accumulator—AOD



Technical Service Information

Diagnosis Guides

The diagnosis guides in this Section can be used as an aid when diagnosing automatic transmissions.

DIAGNOSIS — AUTOMATIC TRANSMISSION

CONDITION	POSSIBLE CAUSE	RESOLUTION
Slow initial engagement.	<ol style="list-style-type: none"> 1. Improper fluid level. 2. Damaged or improperly adjusted linkage. 3. Contaminated fluid. 4. Improper clutch and band application, or low main control pressure. 	<ol style="list-style-type: none"> 1. Perform fluid level check. 2. Service or adjust linkage. 3. Perform fluid condition check. 4. Perform control pressure test.
Rough initial engagement in either forward or reverse. Rough initial engagement — AOD.	<ol style="list-style-type: none"> 1. Improper fluid level. 2. High engine idle. 3. Automatic choke on (warm temp.). 4. Looseness in the driveshaft, U-joints or engine mounts. 5. Improper clutch or band application, or oil control pressure. 6. Sticking or dirty valve body. 	<ol style="list-style-type: none"> 1. Perform fluid level check. 2. Adjust idle to specifications. Check VRV for 7.3L Diesel, C6 applications (Section 17-10). 3. Disengage choke. 4. Service as required. 5. Perform control pressure test. 6. Clean, service or replace valve body.
Harsh engagements — (warm engine).	<ol style="list-style-type: none"> 1. Improper fluid level. 2. TV cable — short. 3. Engine curb idle too high. 4. Valve body bolts — loose/too tight. 5. Valve body dirty/sticking valves. 	<ol style="list-style-type: none"> 1. Perform fluid level check. 2. Adjust TV cable. 3. Check engine curb idle. Check VRV for 7.3L Diesel, C6 applications (Section 17-10). 4. Tighten to specification. 5. Determine source of contamination. Service as required.
No/delayed forward engagement (reverse OK).	<ol style="list-style-type: none"> 1. Improper fluid level. 2. Manual linkage — misadjusted/damaged. 3. Low main control pressure. (Leakage.) Forward clutch stator support seal rings leaking (#3, #4). 4. Forward clutch assembly burnt/damaged/leaking check ball in cylinder/leaking piston seal rings. 5. Valve body bolts — loose/too tight. 6. Valve body dirty/sticking valves. 7. Transmission filter plugged. 8. Pump damaged/leaking. 	<ol style="list-style-type: none"> 1. Perform fluid level check. 2. Check and adjust or service as required. 3. Control pressure test, note results. 4. Perform air pressure test. 5. Tighten to specification. 6. Determine source of contamination. Service as required. 7. Replace filter. 8. Visually inspect pump gears. Replace pump if necessary.
No/delayed reverse engagement (forward OK).	<ol style="list-style-type: none"> 1. Improper fluid level. 2. Manual linkage misadjusted/damaged. 3. Low main control pressure in reverse. Reverse clutch stator support seal rings leaking (#1, #2), (AOD). High reverse clutch OK. 	<ol style="list-style-type: none"> 1. Perform fluid level check. 2. Check and adjust or service as required. 3. Control pressure test.

DIAGNOSIS — AUTOMATIC TRANSMISSION (Continued)

CONDITION	POSSIBLE CAUSE	RESOLUTION
No/delayed reverse engagement (forward OK) (continued).	4. Reverse clutch assembly burnt/worn/leaking check ball in piston/leaking piston seal rings. 5. Valve body bolts loose/too tight. 6. Valve body dirty/sticking valves. 7. Transmission filter plugged. 8. Pump damaged.	4. Perform air pressure test. 5. Tighten to specification. 6. Determine source of contamination. Service as required. 7. Replace filter. 8. Visually inspect pump gears. Replace if necessary.

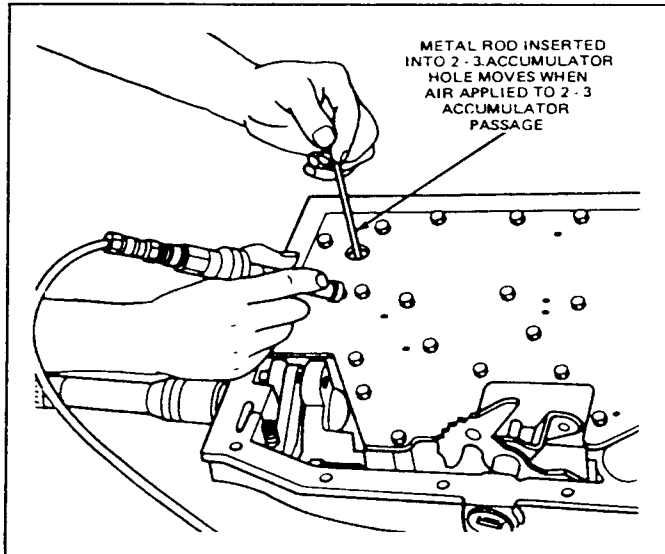

FIG. 23 Air Pressure Test—2-3 Accumulator—AOD

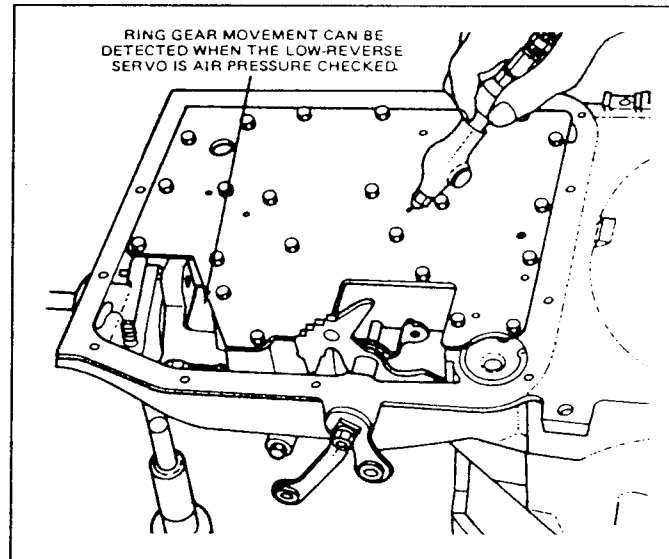

FIG. 25 Air Pressure Test—Low Reverse Servo—AOD

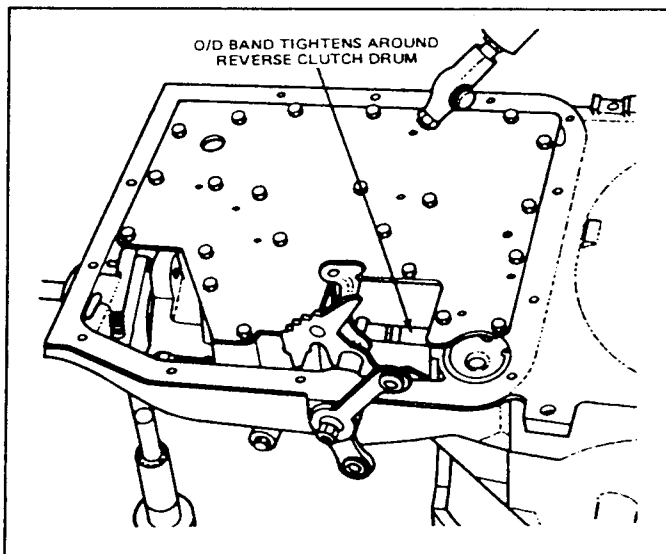

FIG. 24 Air Pressure Test—O/D Servo Apply—AOD

REMOVAL AND INSTALLATION

Vacuum Diaphragm C6

Removal and Installation

1. Disconnect the hose from the vacuum unit.

2. Remove the vacuum unit retaining bracket bolt and bracket (Fig. 28). **Do not pry or bend the bracket.** Pull the vacuum unit from the transmission case.
3. Remove the vacuum unit control rod from transmission case.
4. Install the vacuum unit control rod in transmission case.
5. Push the vacuum unit into the case and secure with the retaining bracket and bolt. Tighten the bolt to 17-21 N·m (12-16 ft-lbs) on C6 transmissions.
6. Install the vacuum unit hose to the diaphragm connector.

Transmission Fluid Drain and Refill

Normal maintenance and lubrication requirements do not necessitate periodic automatic transmission fluid changes.

If a major repair, such as a clutch band, bearing, etc., is required in the transmission, it will have to be removed for service. At this time the converter, transmission cooler and cooler lines must be thoroughly flushed to remove any dirt.

On light trucks equipped with automatic transmissions the following should apply:

When used under continuous or severe conditions, the transmission and the torque converter should be drained and refilled with the



Technical Service Information

DIAGNOSIS — AUTOMATIC TRANSMISSION

CONDITION	POSSIBLE CAUSE	RESOLUTION
No/delayed reverse engagement and/or no engine braking in manual low ①.	<ol style="list-style-type: none"> 1. Improper fluid level. 2. TV cable out of adjustment (AOD). 3. Low reverse servo piston seal leaking. 4. Low reverse band/servo piston burnt/worn (AOD). 5. Planetary low one way clutch damaged. 	<ol style="list-style-type: none"> 1. Perform fluid level check. 2. Service or adjust TV cable. 3. Check and replace piston seal. 4. Perform air pressure test. 5. Determine cause of condition. Service as required.
No engine braking in manual second gear.	<ol style="list-style-type: none"> 1. Intermediate band out of adjustment. 2. Improper band or clutch application, or oil pressure control system. 3. Intermediate servo leaking. 4. Intermediate one way clutch damaged. 5. Polished or glazed band or drum. 	<ol style="list-style-type: none"> 1. Adjust intermediate band. 2. Perform control pressure test. 3. Perform air pressure test of intermediate servo for leakage. Service as required. 4. Replace. 5. Service or replace as required.
Forward engagement slips/shutters/chatters.	<ol style="list-style-type: none"> 1. Improper fluid level. 2. TV cable misadjusted (long) (AOD). 3. Manual linkage misadjusted/damaged. 4. Low main control pressure. 5. Valve body bolts — loose/too tight. 6. Valve body dirty/sticking valves. 7. Forward clutch piston ball check not seating/leaking. 8. Forward clutch piston seals cut/worn. 9. Forward clutch stator support seal rings #3, #4 leaking (AOD). 10. Low one way clutch (planetary) damaged. 	<ol style="list-style-type: none"> 1. Perform fluid level check. 2. Adjust TV cable. 3. Check and adjust or service as required. 4. Control pressure test. 5. Tighten to specification. 6. Determine source of contamination. Service as required. 7. Replace forward clutch cylinder. Service transmission as required. 8. Replace seals and service clutch as required. 9. Replace stator support seal rings. 10. Determine cause of condition. Service as required.
Reverse shudder/chatters/slips.	<ol style="list-style-type: none"> 1. Improper fluid level. 2. Low main control pressure in reverse. 3. Low — reverse servo/ leaking. 4. Low (planetary) one-way clutch damaged. 5. Reverse clutch drum bushing damaged. 6. Reverse clutch stator support seal ring/ring grooves worn/damaged. 7. Reverse clutch piston seals cut/worn. 8. Reverse band out of adjustment or damaged. 9. Looseness in the driveshaft, U-joints or engine mounts. 	<ol style="list-style-type: none"> 1. Perform fluid level check. 2. Control pressure test. 3. Air pressure test; visually inspect seal rings and piston bore. 4. Determine cause of condition. Service as required. 5. Determine cause of condition. Service as required. 6. Determine cause of condition. Service as required. 7. Determine cause of condition. Service as required. 8. AOD has no adjustment. Service as required. 9. Service as required.

specified fluid at intervals directed in the maintenance or owners manual.

Refer to the Truck Performance Specifications Book or the end of this Section for fluid requirements.

NOTE: Fluid level indicator should be used to determine actual fluid requirements. Check fluid level when the transmission is at normal operating temperature. Do not overfill.

Procedures for partial drain and refill, due to in-vehicle repair operation, are as follows:

C6 Transmissions

1. Raise the vehicle on a hoist or jack stands.
2. Place a drain pan under the transmission.
3. Loosen the pan attaching bolts and drain the fluid from the transmission.
4. When fluid has drained to the level of the pan flange, remove the rest of the pan bolts working from the rear and both sides of the pan to allow it to drop and drain slowly.



Technical Service Information

DIAGNOSIS — AUTOMATIC TRANSMISSION

CONDITION	POSSIBLE CAUSE	RESOLUTION
No drive, slips or chatters in first gear in D. All other gears normal. First gear in D or (D) Automatic Overdrive transmission.	1. Damaged or worn planetary one-way clutch.	1. Service or replace one-way clutch.
No drive, slips or chatters in second gear.	1. Intermediate band out of adjustment (C6). 2. Intermediate friction clutch or one-way clutch (AOD). 3. Intermediate clutch piston bleed hole blocked or not positioned at 12 o'clock (AOD). 4. Improper band or clutch application, or control pressure. 5. Damaged or worn intermediate servo piston seals and/or internal leaks. 6. Dirty or sticking valve body. 7. Polished, glazed intermediate band or drum (C6).	1. Adjust intermediate band. 2. Service as required. 3. Clean and install bleed hole at 12 o'clock position. 4. Perform control pressure test. 5. Perform air pressure test. 6. Clean, service or replace valve body. 7. Replace or service as required.
Starts up in 2nd or 3rd.	1. Improper band and/or clutch application, or oil pressure control system. 2. Intermediate clutch pack clearance too tight (AOD). 3. Damaged or worn governor. Sticking governor. 4. Valve body loose. 5. Dirty or sticking valve body. 6. Cross leaks between valve body and case mating surface.	1. Perform control pressure test. 2. Check intermediate clutch pack clearance. 3. Perform governor check. Replace or service governor, clean screen. 4. Tighten to specification. 5. Clean, service or replace valve body. 6. Service or replace valve body and/or case as required.
Shift points incorrect.	1. Improper fluid level. 2. Vacuum line damaged, clogged or leaks (C6). 3. Improper operation of EGR system (C6). 4. TV cable out of adjustment (AOD). 5. Improper speedometer gear installed. 6. Improper clutch or band application, or oil pressure control system. 7. Damaged or worn governor. 8. TV control rod or vacuum diaphragm bent sticking or leaks, (C6). 9. Dirty or sticking valve body. 10. Vacuum regulator valve misadjusted or damaged, (C-6 with 7.3L Diesel).	1. Perform fluid level check. 2. Perform vacuum supply test. Check VRV adjustment on 7.3L Diesel, C6 application. 3. Service or replace as required. 4. Service or adjust TV cable. Check VRV adjustment on 7.3L Diesel, C6 application. 5. Replace gear. 6. Perform shift test and control pressure test. 7. Service or replace governor — clean screen. 8. Replace. 9. Clean, service or replace valve body. 10. Check adjustment and function. Adjust or replace.
All upshifts harsh/delayed or no upshifts.	1. Improper fluid level. 2. AOD Only — TV cable — short. 3. Manual linkage — misadjusted/damaged. 4. Governor sticking. 5. Main control pressure too high. 6. Valve body bolts — loose/too tight. 7. Valve body dirty/sticking valves.	1. Perform fluid level check. 2. Adjust TV cable. Service as required. 3. Check and adjust or service as required. 4. Perform governor test. Service as required. 5. Control pressure test. Service as required. 6. Tighten to specification. 7. Determine source of contamination. Service as required.

DIAGNOSIS — AUTOMATIC TRANSMISSION (Continued)

CONDITION	POSSIBLE CAUSE	RESOLUTION
All upshifts harsh/delayed or no upshifts (continued).	8. Vacuum leak to diaphragm unit (C6). 9. Vacuum regulator valve misadjusted or damaged, (C6 with 7.3L Diesel).	8. Check vacuum lines to diaphragm unit. Service as necessary. Perform vacuum supply and diaphragm tests. Check VRV adjustment on 7.3L Diesel, C6 application. 9. Check adjustment and function. Adjust or replace.

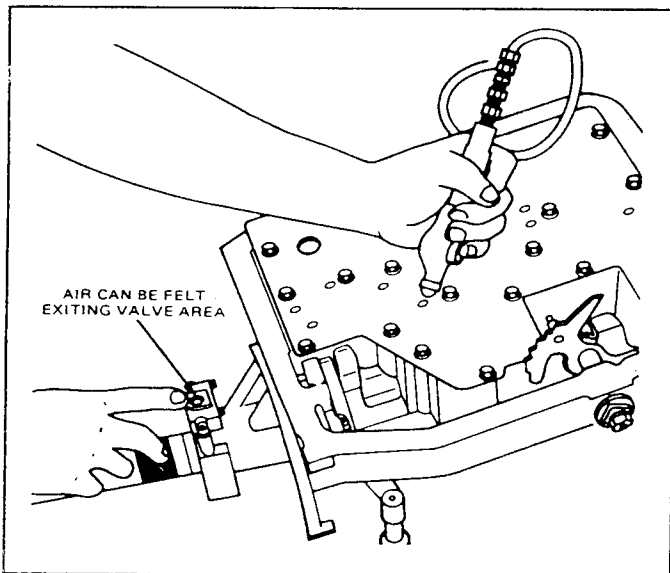

FIG. 26 Air Pressure Test—Line to Governor—AOD

- When all fluid has drained from the transmission, remove and thoroughly clean the pan and the screen. Discard the pan gasket.
- Place a new gasket on the pan, and install the pan on the transmission. Tighten the bolts to specifications.
- Add 4.7 liters (5 quarts) shallow pan, or 5.6 liters (6 quarts) deep pan of fluid to the transmission through the filler tube.
- Check the fluid level.

AOD Transmissions

- Raise the vehicle on a hoist or jack stands.
- Place a drain pan under the transmission.
- Loosen the pan attaching bolts and drain the fluid from the transmission.
- When fluid has drained to the level of the pan flange, remove the rest of the pan bolts working from the rear and both sides of the pan to allow it to drop and drain slowly.
- When all fluid has drained from the transmission, remove and thoroughly clean the pan. Discard the AOD filter, filter gasket, oil pan gasket and valve body gasket.
- Install new oil pan gasket, filter and filter gasket on AOD. **Do not reuse the old one.**
- Place a new gasket on the pan, and install the pan on the transmission. Tighten bolts to specifications.

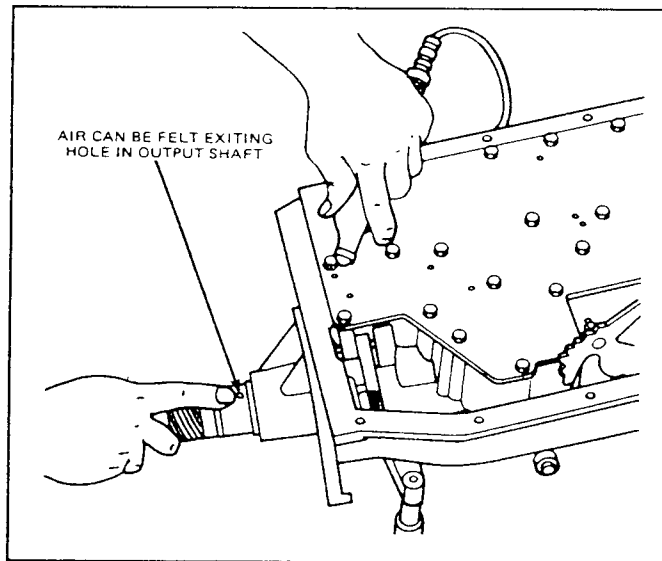

FIG. 27 Air Pressure Test—Governor to Valve Body—AOD

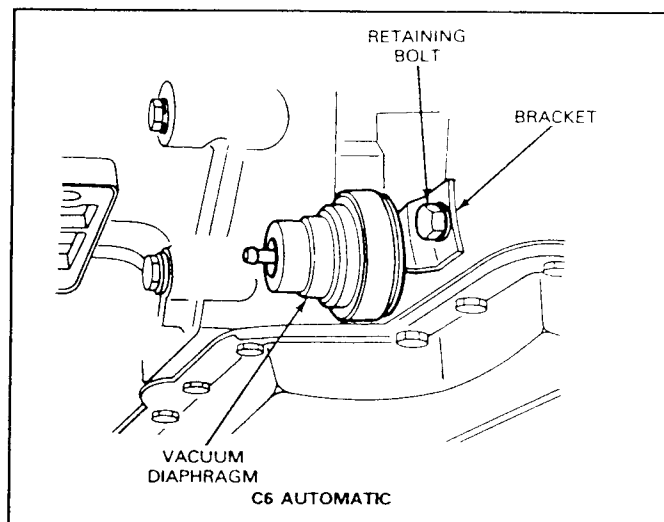

FIG. 28 Vacuum Diaphragm Installed—C-6 Transmission

- Add 2.8 liters (3 quarts) of fluid to the transmission through the filler tube.
- Check the fluid level following the checking procedures as described in this Section.

If it is necessary to perform a complete drain and refill, it will be necessary to remove the residual fluid from the torque converter and the cooler lines. To drain the torque converter:

- Remove the low engine dust cover.



Technical Service Information

DIAGNOSIS — AUTOMATIC TRANSMISSION

CONDITION	POSSIBLE CAUSE	RESOLUTION
Mushy/early all upshifts/pile up upshifts.	<ol style="list-style-type: none"> 1. TV cable misadjusted (long)/sticking/damaged (AOD). 2. Low main control pressure. 3. Valve body bolts loose/too tight. 4. Valve body valve or throttle control valve sticking. 5. Governor valve sticking. 6. TV control rod too short. 7. Vacuum regulator valve misadjusted or damaged. (C6 with 7.3L Diesel.) 	<ol style="list-style-type: none"> 1. Adjust TV cable. Service as required. Check VRV for 7.3L Diesel, C6 application. 2. Control pressure test. Note results. 3. Tighten to specification. 4. Determine source of contamination. Service as required. 5. Perform governor test. Repair as required. 6. Install correct TV control rod. 7. Check adjustment and function. Adjust or replace.
No 1-2 upshift.	<ol style="list-style-type: none"> 1. Improper fluid level. 2. For 7.3L Diesel, C6 application — VRV. 3. Manual linkage — misadjusted/damaged. 4. Low main control pressure to intermediate friction clutch (AOD). 5. Governor valve sticking. Intermediate band out of adjustment (C6). 6. Vacuum diaphragm bent, sticking, leaks. 7. Valve body bolts — loose/too tight. 8. Valve body dirty/sticking valves. 9. Intermediate clutch/band and or servo assembly burnt. 	<ol style="list-style-type: none"> 1. Perform fluid level check. 2. Check VRV for 7.3L Diesel, C6 application. 3. Check and adjust or service as required. 4. Control pressure test. Note results. 5. Perform governor test. Service as required. Adjust intermediate band. 6. Check diaphragm unit. Service as necessary. 7. Tighten to specification. 8. Determine source of contamination. Service as required. 9. Perform air pressure test.
Rough/harsh/delayed 1-2 upshift.	<ol style="list-style-type: none"> 1. Improper fluid level. 2. Poor engine performance. 3. For 7.3L Diesel, C6 application — VRV. 4. Intermediate band out of adjustment (C6). 5. Main control pressure too high. 6. Governor valve sticking. 7. Engine vacuum leak (C6). 8. Valve body bolts — loose/too tight. 9. Valve body dirty/sticking valves. 10. Vacuum regulator valve misadjusted or damaged C6 with 7.3L Diesel. 	<ol style="list-style-type: none"> 1. Perform fluid level check. 2. Tune engine. 3. Check VRV for 7.3L Diesel, C6 application. 4. Adjust intermediate band. 5. Control pressure test. Note results. 6. Perform governor test. Service as required. 7. Check engine vacuum lines. Service as necessary. Check vacuum diaphragm unit. Service as necessary. Perform vacuum supply and diaphragm tests. 8. Tighten to specifications. 9. Determine source of contamination. Service as required. 10. Check adjustment and function. Adjust or replace.



Technical Service Information

DIAGNOSIS — AUTOMATIC TRANSMISSION

CONDITION	POSSIBLE CAUSE	RESOLUTION
Mushy/early/soft/slipping 1-2 upshift.	<ol style="list-style-type: none"> 1. Improper fluid level. 2. Incorrect engine performance. 3. For 7.3L Diesel, C6 application — VRV. 4. Intermediate band out of adjustment (C6) 5. Low main control pressure. 6. Valve body bolts loose/too tight. 7. Valve body dirty/sticking valves. 8. Intermediate friction clutch burnt/worn (AOD). 9. Governor valve sticking 10. Damaged intermediate servo or band. 11. Polished, glazed band or drum (C6). 12. Vacuum regulator valve misadjusted or damaged. (C-6 with 7.3L Diesel.) 	<ol style="list-style-type: none"> 1. Perform fluid level check. 2. Tune adjust engine idle as required. 3. Check VRV for 7.3L Diesel, C6 application. 4. Adjust intermediate band. 5. Control pressure test. Note results. 6. Tighten to specification. 7. Determine source of contamination. Service as required. 8. Determine cause of condition. Service as required. 9. Perform governor test. Service as required. 10. Perform air pressure test. Service as required. 11. Service or replace as required. 12. Check adjustment and function. Adjust or replace.
No 2-3 upshift.	<ol style="list-style-type: none"> 1. Low fluid level. 2. For 7.3L Diesel, C6 application — VRV. 3. Low main control pressure to direct clutch. 4. Valve body bolts — loose/too tight. 5. Valve body dirty/sticking valves. 6. Direct clutch (or reverse/high clutch) assembly burnt/worn. 7. Converter damper hub/weld broken (AOD). 	<ol style="list-style-type: none"> 1. Perform fluid level check. 2. Check VRV for 7.3L Diesel, C6 application. 3. Control pressure test. Note results. 4. Tighten to specification. 5. Determine source of contamination, then service as required. 6. Stall test. Determine cause of condition. Service as required. 7. Perform converter damper hub/weld check. Replace torque converter if required.
Harsh/delayed 2-3 upshift.	<ol style="list-style-type: none"> 1. Incorrect engine performance. 2. Engine vacuum leak (C6). 3. For 7.3L Diesel, C6 application — VRV. 4. 2-3 accumulator piston apply passage plugged/omitted (AOD). 5. 2-3 accumulator piston seals cut/worn (AOD). 6. Damaged 2-3 accumulator (AOD). 	<ol style="list-style-type: none"> 1. Check engine tune-up. 2. Check engine vacuum lines. Service as necessary. Check vacuum diaphragm unit. Service as necessary. Perform vacuum supply and diaphragm tests. Check VRV for 7.3L Diesel, C6 application. 3. Check VRV for 7.3L Diesel, C6 application. 4. Remove 2-3 accumulator piston and visually inspect or air test for plugging condition or omission. 5. Replace seals, determine cause of condition. Service as required. 6. Service as required.



Technical Service Information

DIAGNOSIS — AUTOMATIC TRANSMISSION (Continued)

CONDITION	POSSIBLE CAUSE	RESOLUTION
Harsh/delayed 2-3 upshift (continued)	7. Damaged or worn intermediate servo release and high clutch piston check ball (C6).	7. Air pressure test the intermediate servo apply and release the high clutch piston check ball. Service as required.
	8. Valve body bolts — loose/too tight.	8. Tighten to specification.
	9. Valve body dirty/sticking valves. 2-3 capacity modulator valve (AOD).	9. Determine source of condition. Service as required.
	10. Vacuum diaphragm or TV control rod bent, sticking, leaks.	10. Check diaphragm and rod. Replace as necessary.
	11. Vacuum regulator valve misadjusted or damaged. (C-6 with 7.3L Diesel.)	11. Check adjustment and function. Adjust or replace.

CD4918-2C

2. Rotate the torque converter until the drain plug comes into view.
3. Remove the drain plug and allow the transmission fluid to drain. Note: It is recommended that this procedure be performed prior to other operations to allow sufficient time for the converter to drain properly.
4. Flush the cooler lines completely.
5. When adding fluid, fill to the capacity required for that transmission.

Fluid Cooler Lines

When fluid leakage is found from the fluid cooler, the cooler must be replaced. Cooler replacement is described in the Cooling System Section of Group 27.

When one or more of the fluid cooler steel tubes must be replaced, each replacement tube must be fabricated from the same size steel tubing as the original line.

Using the old tube as a guide, bend the new tube as required. Add the necessary fittings, and install the tube.

After the fittings have been tightened, add fluid as needed, and check for fluid leaks.

CLEANING AND INSPECTION

Transmission

It is important to completely clean all transmission components, including converter, cooler, cooler lines, main control valve body, governor, all clutches, and all check balls after any transmission servicing that generates contamination. These contaminants are a major cause for recurring transmission troubles and must be removed from the system before the transmission is put back into service. The cleaning of debris from the direct clutch piston, the forward clutch cylinder, and reverse clutch piston check balls are often omitted. This omission can lead to a repeat servicing of the transmission.

During overhaul inspect all hardware for evidence of overheating. Any overheating will be indicated by heat stained blue surfaces.

Clean the parts with suitable solvent and use moisture-free air to dry off all the parts and clean out fluid passages.

The composition clutch plates, bands and synthetic seals should not be cleaned in a vapor degreaser or with any type of detergent solution. To clean these parts, wipe them off with a lint-free cloth. New clutch plates or bands should be soaked in transmission fluid specified for that transmission type for fifteen minutes before being assembled.

Do not reuse the control valve body to filter gasket or try to clean in solvent and reuse the oil filter on AOD. Upon reassembly of the transmission replace both the valve body to filter gasket and the oil filter on the AOD transmission.

Control Valve Body

1. Clean all parts thoroughly in clean solvent, and blow dry with moisture-free compressed air. **If the valve body-to-screen gasket is removed on a C6 Transmission, the gasket should not be cleaned in a degreaser, solvent or any type of detergent solution. To clean the gasket, wipe it off with a lint-free cloth. For AOD, replace the valve body to filter gasket.**
2. Inspect all valve and plug bores for scores. Check all fluid passages for obstructions. Inspect the check valve for free movement. Inspect all mating surfaces for burrs or distortion. Inspect all plugs and valves for burrs or scores. Use crocus cloth to polish valves and plugs. Avoid rounding the sharp edges of the valves and plugs with the cloth.
3. Inspect all springs for distortion. Check all valves and plugs for free movement in their respective bores. Valves and plugs, when dry, must fall from their own weight in their respective bores.
4. On a C6 transmission, inspect the separator plate screen for obstructions. The screen must be clean and free of foreign material. If contaminated, remove it from separator plate, clean in a suitable solvent, and thoroughly blow clean with compressed air.
5. Roll the manual valve on a flat surface to check for bent condition.



Technical Service Information

DIAGNOSIS — AUTOMATIC TRANSMISSION

CONDITION	POSSIBLE CAUSE	RESOLUTION
Soft/early/mushy 2-3 upshift.	<ol style="list-style-type: none"> 1. For 7.3L Diesel, C6 application — VRV. 2. Valve body bolts loose/too tight. 3. Valve body dirty/sticking valves. 4. AOD ONLY — Direct clutch assembly or reverse/high clutch/burnt worn. 5. Vacuum diaphragm or TV control rod bent, sticking, leaks. 6. Vacuum regulator valve misadjusted or damaged. (C-6 with 7.3L Diesel). 	<ol style="list-style-type: none"> 1. Check VRV for 7.3L Diesel, C6 application. 2. Tighten to specification. 3. Determine source of contamination. Service as required. 4. Stall test. Determine cause of condition. Service as required. 5. Check diaphragm and rod. Replace as necessary. 6. Check adjustment and function. Adjust or replace.
AOD ONLY — No. 3-4 upshift (stays in 3rd gear).	<ol style="list-style-type: none"> 1. Direct clutch circuit leakage. NOTE: Direct clutch plates burnt will help to confirm leakage in the direct clutch circuit. Replacing only the plates and not finding the cause will result in a repeat repair. 2. Valve body contamination/sticking valves. 	<ol style="list-style-type: none"> 1. Perform Direct Clutch Pressure Test. <ul style="list-style-type: none"> • Check torque on valve body bolts. Torque not to spec. (loose); can cause leakage. • Check for nicks or porosity in the case passages. (Valve body to case mating surface.) Replace case for the above. • Direct clutch piston check ball leaking. Perform check ball leakage procedure; found in cleaning and inspection portion. Replace piston if leakage confirmed. • Direct clutch piston seal rings (inner and outer) leaking. Replace. • Check the direct clutch output shaft seal rings (#5, #6). They should move freely on the output shaft. Check for metal shaving contamination or burrs between the seal and the output shaft. Replace as necessary. • Check the large seal rings on the output shaft for freedom of movement. Check for contamination such as metal shavings on the output shaft. Replace as necessary. NOTE: The four large seal rings are numbered #7, #8, #9, #10. Seal rings #7, #8 (closest to the output shaft hub) are for the direct clutch. Seal rings #9, #10 (closest to the governor) are for the governor. • Inspect the output shaft feed passages and the cup plug for leakage. 2. Clean the valve body. Check for sticking valves as follows: Overdrive servo regulator valve; 3-4 shift valve; 3-4 TV modulator valve; orifice control valve. If any valves are sticking and they cannot be freed, replace valve body.

Intermediate Servo

C6

1. Inspect the servo bore for cracks and the servo piston for damage, and the piston bore and the servo piston stem for scores. Check fluid passages for obstructions. Replace damaged seals.
2. Check the servo spring and servo band strut(s) for distortion.
3. Inspect the cover seal and gasket cover sealing surface for damage.

Low-Reverse Servo

AOD

1. Inspect the servo body for cracks and the piston bore for scores.
2. Check the fluid passages for obstructions.
3. Inspect the band and the struts for distortion. Inspect the band ends for cracks.
4. Inspect the servo spring for distortion.



Technical Service Information

DIAGNOSIS — AUTOMATIC TRANSMISSION (Continued)

CONDITION	POSSIBLE CAUSE	RESOLUTION
AOD Only — No. 3-4 upshift (stays in 3rd gear) (continued).	<ol style="list-style-type: none"> 3. Main control gasket distortion. 4. Case being out-of-flat can cause sticking valve. 5. Governor leakage. 	<ol style="list-style-type: none"> 3. Check to see if main control gasket is blocking an orifice. Replace gasket. 4. Reduce valve body bolt torque to minimum side of spec. 80 in-lbs. 5. Check last two large seal rings on the output shaft (#9, #10). They should move freely. Check for metal shaving contamination or burrs between the seal and output shaft. Replace as necessary. <ul style="list-style-type: none"> • Check the seal ring bore at the rear of case for scoring. Light scoring is permissible. Deep grooving indicates case wear. Replace case for deep grooving. • Check the governor to output shaft retaining ring to make sure it is properly seated on the output shaft. Repair as necessary. • Check the fit of the governor counterweight on the output shaft. If the fit is sloppy, replace the counterweight.
AOD Only — Harsh/delayed 3-4 upshift.	<ol style="list-style-type: none"> 1. Valve body bolts — loose/too tight. 2. Valve body dirty/sticking valves. 3. Incorrect engine performance. 4. 3-4 accumulator piston seals worn/cut. 5. 3-4 accumulator piston apply passage blocked. 	<ol style="list-style-type: none"> 1. Tighten to specification. 2. Determine source of contamination. Service as required. 3. Tune, adjust engine idle as required. 4. Determine cause of condition. Service as required. 5. Determine cause of condition. Service as required.
Slipping 4th gear (engine flare-up/no 4th gear drive capability).	<ol style="list-style-type: none"> 1. Overdrive circuit leakage or blocked passage. NOTE: Burnt overdrive band will help to confirm leakage in the overdrive circuit. Replacing only the overdrive band without finding the cause will result in a repeat repair. 2. Overdrive servo piston not applying overdrive band/band not applying. 3. Overdrive band mislocated. 4. Converter damper plate and hub fracturing, the weld and/or rivets fatiguing, or the damper springs breaking. 5. Direct driveshaft splines distorted. 	<ol style="list-style-type: none"> 1. Check valve body bolt torque. Torque not to spec. (loose); can cause leakage. Spec. is 80-100 in-lbs. <ul style="list-style-type: none"> • Overdrive servo cover O-rings leaking. Replace O-rings. • Overdrive servo piston seal leaking. Replace seal. • Overdrive servo cover cracked/porous. Coat cover with fluid. Apply air to overdrive servo, apply passage using tool (T80L-77030-B). Observe to see if air bubbles are present on overdrive servo cover. Replace cover if air bubbles are present. 2. Overdrive servo case apply passage blocked. Air pressure test. Replace case if necessary. 3. Overdrive servo piston not seated to the band end seat. Repair. <ul style="list-style-type: none"> • Overdrive band not seated to anchor pin. Repair. 4. Perform converter damper/hub assembly weld check procedure. Use special service tools T83L-7902-A. Replace converter if shaft turns more than two degrees or if there is a grinding noise while applying 50 lbs. ft. torque. 5. Check splines on both ends of the direct driveshaft. Check splines in direct clutch cylinder. Replace direct driveshaft and hardware that splines to it for distortion.



Technical Service Information

DIAGNOSIS — AUTOMATIC TRANSMISSION

CONDITION	POSSIBLE CAUSE	RESOLUTION
Erratic shifts.	<ol style="list-style-type: none">Poor engine performance.TV cable — binding/sticking (AOD).Valve body bolts — loose/too tight.Valve body dirty/sticking valves.Governor valve stuck.Output shaft collector body seal rings damaged.	<ol style="list-style-type: none">Check engine tune-up.Inspect throttle linkage. Service as required. Check VRV for 7.3L Diesel, C6 application.Tighten to specification.Line pressure test, note results. Determine source of contamination. Service as required.Perform governor test. Service as required.Service as required.
Shifts 1-3 in D. (D or $\text{\textcircled{D}}$ range for AOD).	<ol style="list-style-type: none">Intermediate band out of adjustment (C6).Intermediate friction clutch burnt/damaged (AOD).Intermediate one-way clutch damaged (AOD).Damaged intermediate servo and/or internal leaks (C6).Improper band or clutch application, or oil pressure control system.Polished, glazed band or drum (C6).Dirty or sticking valve body.Governor valve stuck.	<ol style="list-style-type: none">Adjust band.Determine cause of condition. Service as required.Determine cause of condition. Replace/service as required.Perform air pressure test. Service front servo and/or internal leaks.Perform control pressure test.Service or replace band or drum.Clean, service or replace valve body.Perform governor test. Service as required.
Engine over-speeds on 2-3 shift.	<ol style="list-style-type: none">Linkage out of adjustment.Improper band or clutch application, or oil pressure control system.Intermediate servo piston seals cut/leaking.Dirty or sticking valve body.Converter damper/hub brake (AOD).	<ol style="list-style-type: none">Service or adjust linkage. Check VRV for 7.3L Diesel, C6 application.Perform control pressure test.Replace seals. Check for leaks.Clean, service or replace valve body.Perform converter damper/hub weld check. Replace converter if necessary.
AOD Only — Shift hunting 3-4, 4-3.	<ol style="list-style-type: none">Poor engine performance — EGR solenoid defective.Manual linkage misadjusted.	<ol style="list-style-type: none">Tune-up engine — Replace solenoid.Check and adjust or service as required.
Rough/shudder 3-1 shift at closed throttle in D. (D range for AOD).	<ol style="list-style-type: none">Incorrect engine idle or performance.Improper linkage adjustment.Improper clutch or band application or oil pressure control system.Improper governor operation.Dirty or sticking valve body.	<ol style="list-style-type: none">Tune, and adjust engine idle.Service or adjust linkage. Check VRV for 7.3L Diesel, C6 application.Perform control pressure test.Perform governor test. Service as required.Clean, service or replace valve body.
AOD Only — Rough or mushy 4-2 or 3-1 shift.	<ol style="list-style-type: none">Incorrect engine performance.Improper throttle or manual linkage adjustment.Improper application of intermediate friction and one way clutch.Dirty or sticking valve body.	<ol style="list-style-type: none">Tune, adjust engine idle as required.Service or adjust linkage.Service as required.Clean, service or replace valve body.



Technical Service Information

DIAGNOSIS — AUTOMATIC TRANSMISSION

CONDITION	POSSIBLE CAUSE	RESOLUTION
No forced downshifts.	<ol style="list-style-type: none"> 1. Kickdown linkage out of adjustment (C6). 2. Damaged internal kickdown linkage (C6). 3. Damaged, misadjusted (long) TV cable (AOD). 4. Improper clutch or band application, or oil pressure control system. 5. Dirty or sticking governor. 6. Dirty or sticking valve body. 	<ol style="list-style-type: none"> 1. Service or adjust linkage. 2. Service internal kickdown linkage. 3. Inspect and adjust TV cable. 4. Perform control pressure test. 5. Perform governor test. Service or replace governor, clean screen. 6. Clean, service, or replace valve body.
Engine over-speeds on 3-2 downshift (C5).	<ol style="list-style-type: none"> 1. Linkage out of adjustment. 2. Intermediate band out of adjustment. 3. Improper band or clutch application, and one way clutch, or oil pressure control system. 4. Damaged or worn intermediate servo. 5. Polished, glazed band or drum. 6. Dirty or sticking valve body. 	<ol style="list-style-type: none"> 1. Service or adjust linkage. Check VRV for 7.3L Diesel, C6 application. 2. Adjust intermediate band. 3. Perform control pressure test service clutch. 4. Air pressure test check the intermediate servo. Service servo and/or seals. 5. Service or replace as required. 6. Clean, service or replace valve body.
Shift efforts high.	<ol style="list-style-type: none"> 1. Manual shift linkage damaged/ misadjusted. 2. Inner manual lever nut loose. 3. Manual lever retainer pin damaged. 	<ol style="list-style-type: none"> 1. Check and adjust or service as required. 2. Tighten nut to specification. 3. Adjust linkage and install new pin.
Transmission overheats.	<ol style="list-style-type: none"> 1. Improper fluid level. 2. Incorrect engine idle, or performance. 3. Improper clutch or band application, or oil pressure control system. 4. Restriction in cooler or lines. 5. Seized converter one-way clutch. 6. Dirty or sticking valve body. 	<ol style="list-style-type: none"> 1. Perform fluid level check. 2. Tune, or adjust engine idle. 3. Perform control pressure test. 4. Service restriction. 5. Replace one-way clutch. 6. Clean, service or replace valve body.
Transmission clunk or squawk during 1-2 or 2-3 shift (AOD).	<ol style="list-style-type: none"> 1. Intermediate clutch piston bleed hole blocked or not positioned at 12 o'clock. 2. Anti-clunk spring not positioned. 3. Converter damper spring broken. 	<ol style="list-style-type: none"> 1. Clean piston and install bleed hole at 12 o'clock position. 2. Secure anti-clunk spring. 3. Perform converter damper hub weld check.
Transmission leaks.	<ol style="list-style-type: none"> 1. Case breather vent. 2. Leakage at gasket, seals, etc. 	<ol style="list-style-type: none"> 1. Check the vent for free breathing. Repair as required. 2. Remove all traces of lube on exposed surfaces of transmission. Check the vent for free breathing. Operate transmission at normal temperatures and perform fluid leakage check. Service as required.
Poor vehicle acceleration.	<ol style="list-style-type: none"> 1. Poor engine performance. 2. Torque converter one-way clutch locked up. 	<ol style="list-style-type: none"> 1. Check engine tune up. 2. Replace torque converter.
Transmission noisy — valve resonance.	<ol style="list-style-type: none"> 1. Improper fluid level. 2. Linkage out of adjustment. 3. Improper band or clutch application, or oil pressure control system. 4. Cooler lines grounding. 5. Dirty or sticking valve body. 6. Internal leakage or pump cavitation. 	<ol style="list-style-type: none"> 1. Perform fluid level check. 2. Service or adjust linkage. 3. Perform control pressure test. 4. Free up cooler lines. 5. Clean, service or replace valve body. 6. Service as required.

NOTE: Gages may aggravate any hydraulic resonance. Remove gage and check for resonance level.



Technical Service Information

DIAGNOSIS — AUTOMATIC TRANSMISSION

CONDITION	POSSIBLE CAUSE	RESOLUTION
AOD only, harsh coasting downshift clunk.	<ol style="list-style-type: none"> 1. Anti-clunk spring not seated properly. 2. TV cable misadjusted (short). 	<ol style="list-style-type: none"> 1. Re-position anti-clunk spring properly. 2. Adjust TV cable, repair as required.
AOD only, initial engagement clunk (engine warm). NOTE: Refer also to rough initial engagement.	<ol style="list-style-type: none"> 1. Engine RPM's above specification. 2. TV cable misadjusted. 3. Worn/damaged/loose. <ol style="list-style-type: none"> A. U-joint (front/rear) B. Slip yoke C. Rear axle D. Rear suspension 4. Excessive transmission end play. 	<ol style="list-style-type: none"> 1. Adjust engine RPM's to specification. 2. Adjust TV cable. 3. Service as necessary. 4. Check transmission end play according to shop manual procedure in Section 17-20. Replace selective thrust washer if necessary.
Vehicle will not start.*	<ol style="list-style-type: none"> 1. Misadjusted neutral start switch (C6). 2. Misadjusted ignition switch. 3. Defective ignition switch. 4. Defective neutral start switch. 	<ol style="list-style-type: none"> 1. Adjust neutral start switch (C6). 2. Adjust ignition switch. 3. Replace ignition switch. 4. Replace neutral switch.

*For 7.3L Diesel Engines equipped with C6 Transmission,

5. Inspect the band lining for excessive wear and bonding to the metal band.
6. Replace damaged seals.

Overdrive Servo

AOD

1. Inspect the servo cover for cracks and the piston bore for scores.
2. Check the fluid passages for obstructions.
3. Inspect the band for wear or damage. The apply rod should be securely attached to the piston.
4. Inspect the servo spring for distortion.
5. Inspect the band lining for excessive wear and bonding to the metal band.
6. Replace damaged seals.

Extension Housing

1. Inspect the housing for cracks. Inspect the gasket surface for burrs or warpage.
2. Inspect the bushing for scores or wear. Replace if required.
3. Inspect the rear seal for hardness, cracks, or wear. If the seal shows wear or deterioration, replace the seal.
4. Inspect the seal counterbore and remove all burrs and scores with crocus cloth.

Governor

1. Inspect the governor valves and bores for scores. Minor scores may be removed from the valves with

crocus cloth. Replace the governor if the valves or body is deeply scored.

2. On AOD transmission, inspect the governor screen for obstructions. The screen must be free of foreign material. If contaminated, clean thoroughly in a suitable solvent and blow dry with compressed air.
3. Check for free movement of the valves in the bores. The valves should slide freely of their own weight in the bores when dry. Inspect fluid passages in the valve body and counterweight for obstructions. **All fluid passages must be clean.**
4. Inspect the mating surfaces of the governor body and governor distributor (C6) for burrs and distortion. Mating surfaces must be smooth and flat.
5. Check the mating surface of the governor valve and the counterweight on Automatic Overdrive transmission for burrs or scratches.

Front Pump

1. Inspect the mating surfaces of the pump body and case for burrs.
2. Inspect the drive and driven gear bearing surface for scores and check gear teeth for burrs.
3. Inspect the front pump seal for cuts or nicks, and the pump bushing for scoring.
4. Check the fluid passages for obstructions.
5. If any parts are found damaged or worn, replace the pump as a unit. Minor burrs and scores may be removed with crocus cloth.



Technical Service Information

TRANSMISSION NOISY — OTHER THAN VALVE RESONANCE

TEST STEP		RESULT	ACTION TO TAKE
1	VERIFY NOISE <ul style="list-style-type: none"> • Check for gear noise to verify if within normal range. 	Noise within normal range	Normal condition.
		Noise not within normal range	GO to 2.
2	LINKAGE CHECK <ul style="list-style-type: none"> • Check linkage for proper adjustment, wear or damage. 		GO to 3.
			SERVICE, REPLACE and/or ADJUST linkage as required.
3	FLUID CHECK <ul style="list-style-type: none"> • Check the fluid for proper level and/or contamination. ① 	Fluid level between ADD and FULL marks	GO to 4.
		Fluid level beneath ADD mark	ADD specified fluid to bring level between ADD and FULL marks with vehicle at operating temperature. GO to 4.
		Fluid contaminated	DISASSEMBLE, CLEAN and SERVICE transmission. FLUSH torque converter and cooler.
4	STALL TEST <ul style="list-style-type: none"> • Perform the Stall Test as described under Stall Test in the Diagnosis and Testing portion of this section. 	Noise stops	GO to 5.
		Noise doesn't stop	EXAMINE torque converter and pump. SERVICE or REPLACE as required. Also CHECK for loose torque converter to flywheel housing bolts or nuts.
5	NOISE CHECK <ul style="list-style-type: none"> • Run transmission in all gears and check for noise. 	Noise doesn't stop in any gear	GO to 6.
		Noise stops in Low and R only	SERVICE front planetary and/or one-way clutch.
		Noise stops in 2, HIGH and R only	SERVICE rear planetary.
		HIGH only	SERVICE both planetaries.
6	SPEEDOMETER GEAR <ul style="list-style-type: none"> • Remove the speedometer gear and check for noise. 	Noise stops	REPLACE speedometer gear.
		Noise doesn't stop	CHECK extension housing bushing, seal or driveshaft. SERVICE or REPLACE as required

NOTE: AOD transmission has only one gear set. Gear noise requires the replacement of the planetary carrier assembly.
 ① For definition of contamination, refer to Transmission Fluid Condition Check in the Diagnosis and Testing portion of this section.

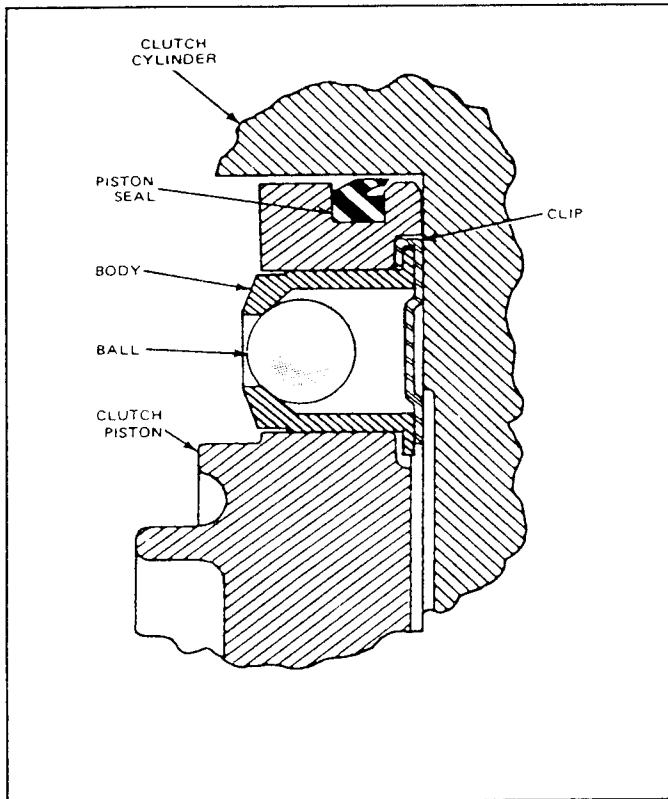

FIG. 29 Clutch Piston Check Ball

- On a C6 and AOD transmission, check the large seal ring groove of the pump body for damage. Check the gasket mating surface of the pump body for damage.

Reverse-High Clutch—C6—Reverse Clutch—AOD

- Inspect the drum band surface, the bushing, and thrust surfaces for scores. Minor scores may be removed with crocus cloth. **Badly scored parts must be replaced.**
- Inspect the clutch piston bore and the piston inner and outer bearing surfaces for scores. Check the air bleed ball valve in the clutch piston for free movement. Check the orifice to make sure it is not plugged.
- Check the fluid passages for obstructions. All fluid passages must be clean and free of obstructions.
- Inspect the clutch plates for wear, scoring, and fit on the clutch hub serrations. Replace all plates that are badly scored, worn, or do not fit freely in the hub serrations.
- Inspect the clutch pressure plate for scores on the clutch plate bearing surface. Check the clutch release spring(s) for distortion.
- The clutch piston has a check ball similar to Fig. 29. Inspect the check ball for freedom of movement and proper seating.

Forward Clutch

- Inspect the clutch cylinder thrust surfaces, piston bore, and clutch plate serrations for scores or burrs. Minor scores or burrs may be removed with crocus cloth. Replace the clutch cylinder if it is badly scored or damaged.

- Check the fluid passage in the clutch cylinder for obstructions. Clean out all fluid passages. Inspect the clutch piston for scores and replace if necessary. Inspect the piston check ball for freedom of movement and proper seating (Fig. 29). AOD—Check both check balls in the forward clutch cylinder for freedom of motion.
- Check the clutch release spring (C6 only) for distortion and cracks. Replace the spring if distorted or cracked.
- Inspect the composition clutch plates, steel clutch plates, and clutch pressure plate for worn or scored bearing surfaces. Replace all parts that are deeply scored.
- Check the clutch hub thrust surfaces for scores and the clutch hub splines for wear.
- Check the splines on the stator support for wear. Inspect the bushing in the stator support for scores. Check the input shaft (C6) for damaged or worn splines. Replace shaft if the splines are excessively worn.

Direct Clutch—AOD

- Inspect the clutch cylinder thrust surfaces, piston bore, and clutch plate splines for scores or burrs. Minor scores or burrs may be removed with crocus cloth. Replace the clutch cylinder if it is badly scored or damaged.
- Check the fluid passage in the clutch cylinder for obstructions. Clean out all fluid passages. Inspect the clutch piston for scores and replace if necessary. Inspect the piston check ball for freedom of movement and proper seating (Fig. 29). Perform the Direct Clutch Piston Check Ball Leakage procedure.
- Check the clutch release springs and retainer for distortion and cracks. Replace the springs and retainer if distorted or cracked.
- Inspect the friction clutch plates, steel clutch plates, and clutch pressure plate for worn or scored bearing surfaces. Replace all parts that are deeply scored or polished.
- Check the clutch plates for flatness and fit on the clutch hub splines. Discard any plate that does not slide freely on the splines or that is not flat.
- Check the clutch hub thrust surfaces for scores and the clutch hub splines for wear.
- Check the splines on the direct drive shaft for wear, replace the shaft if the splines are excessively worn.

Direct Clutch Piston Check Ball Leakage Procedure

Direct clutch piston check ball—Inspect the piston check ball for freedom of movement. Improper seating of check ball will cause leakage. Leakage can be detected by turning the piston upside down (flat side of piston facing you) allowing the check ball to seat in the piston. Pour a small quantity of solvent over the check ball. If solvent drips past the check ball, replace the piston.

Low—Reverse Clutch—C6

- Inspect the clutch cylinder piston bore and clutch plate serrations for scores or burrs. Minor scores or

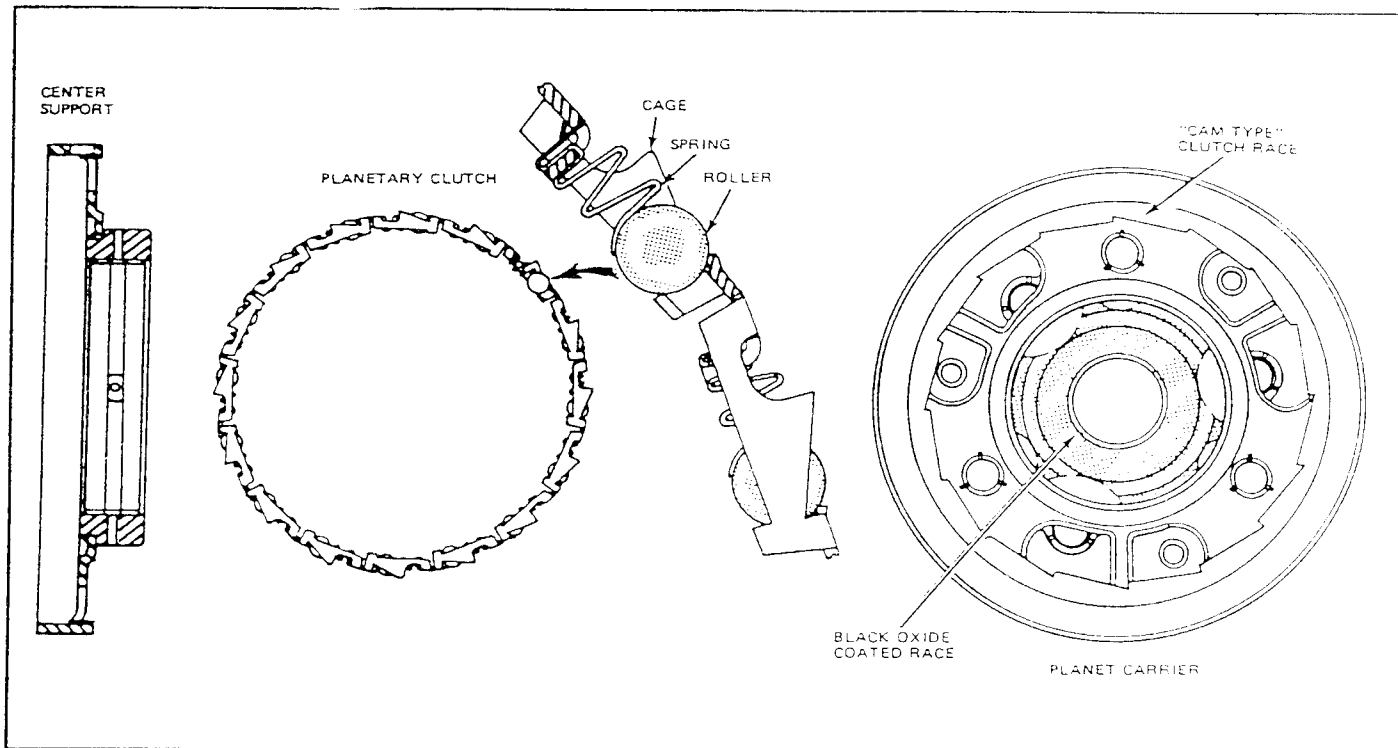

FIG. 30 Roller Type Planetary Clutch, Carrier and Center Support—AOD

burrs may be removed with crocus cloth. Replace the case if it is badly scored or damaged.

2. Check the fluid passage in the case for obstructions (Fig. 16). Clean out all fluid passages. Inspect the clutch piston for scores and replace if necessary.
3. Check the piston return springs for distortion. Check the piston return spring retainer for flatness.
4. Inspect the composition clutch plates, steel clutch plates and clutch pressure plate for worn or scored bearing surfaces. Replace all parts that are deeply scored.
5. Check the clutch hub splines.

Intermediate Clutch—AOD

1. Inspect the piston bore in the rear of the pump body for scores or burrs. Minor damage can be repaired with a crocus cloth.
2. Check and clean all fluid passages in the case and pump and the piston. Inspect both lip seals and replace if damaged.
NOTE: Upon reassembly the small drilled hole in the piston must be located toward the top of the transmission (12 o'clock position).
3. Check the springs and spring retainer for damage. Note how the retainer is held to the body with tabs.
4. Inspect composition clutch plates, steel clutch plates and pressure plate. Replace any badly worn or scored parts.

Planetary One-Way Clutch

1. Inspect the intermediate outer and inner races for scores or damaged surface areas where rollers contact the races. If the intermediate one-way clutch inner race on the AOD transmission is

damaged, the reverse clutch drum must be replaced.

2. Inspect the rollers and springs for excessive wear or damage.
3. Inspect the spring and roller cage for bent or damaged spring retainers.

Planet Carrier and Center Support (AOD)

1. Inspect the clutch outer race, inner race, band surface, pinion gears, bearings, and thrust washer (Fig. 30) for roughness.
2. Inspect the center support bushing for roughness.
3. Inspect one way clutch, springs, rollers and springs.

Converter and Fluid Cooler

When internal wear or damage has occurred in the transmission, metal particles, clutch plate material, or band material may have been carried into the converter and oil cooler. These contaminants are a major cause of recurring transmission troubles and **MUST** be removed from the system before the transmission is put back into service.

Whenever a transmission has been disassembled to replace worn or damaged parts or because the valve body sticks from foreign material, the converter and oil cooler **MUST** be cleaned by using the Rotunda torque Converter Cleaner (model 014-00028) or equivalent. Under **NO** circumstances should an attempt be made to clean converters by hand agitation with solvent.

Converter End Play and One Way Clutch Check

The Tools T76L-7902-C and T77L-7902-R shown in Fig. 31 are used to check the converter one-way clutch.

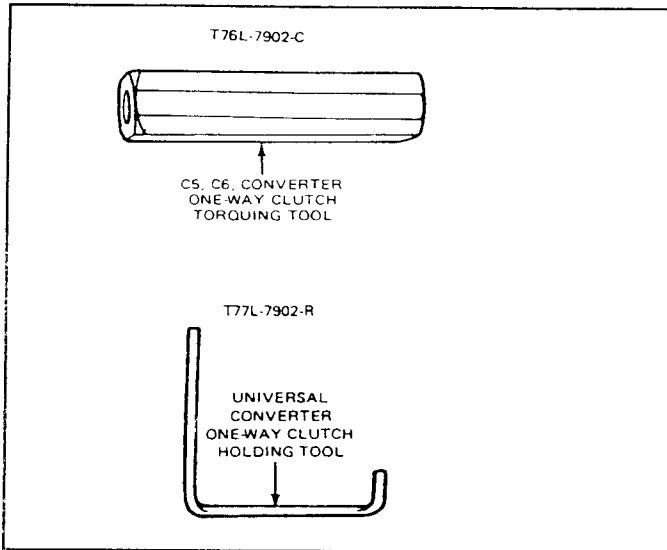

FIG. 31 Converter One Way Clutch Check Tools

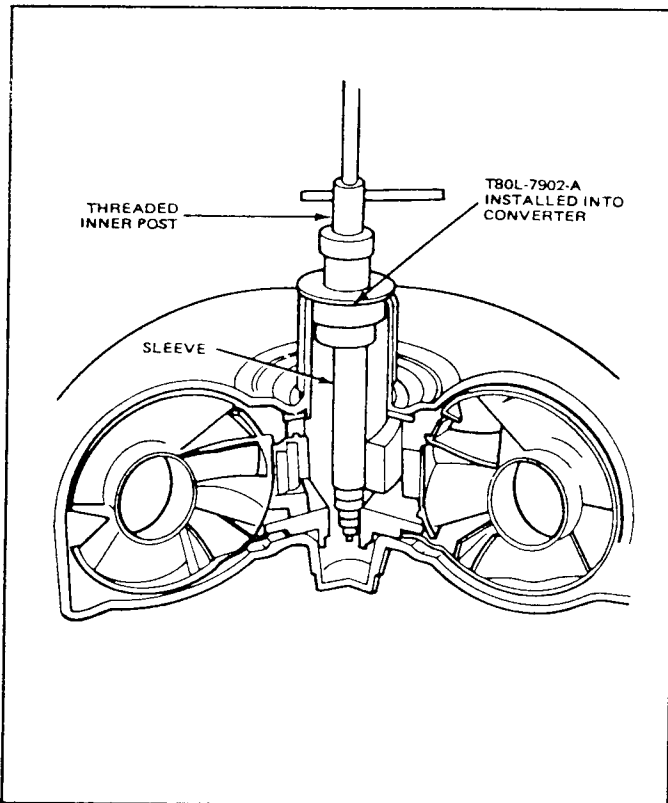

FIG. 32 End Play Checking Tool Installed

End Play Check

1. Insert Tool T80L-7902-A into the converter pump drive hub until it bottoms (Fig. 32).
2. Expand the sleeve in the turbine spline by tightening the threaded inner post, (Fig. 32), until the tool is securely locked into the spline.
3. Attach a dial indicator (with bracketry) TOOL-4201-C to the tool (Fig. 33). Position the indicator button on the converter pump drive hub, and set the dial face at 0 (zero).
4. Lift the tool upward as far as it will go and note the indicator reading. The indicator reading is the total

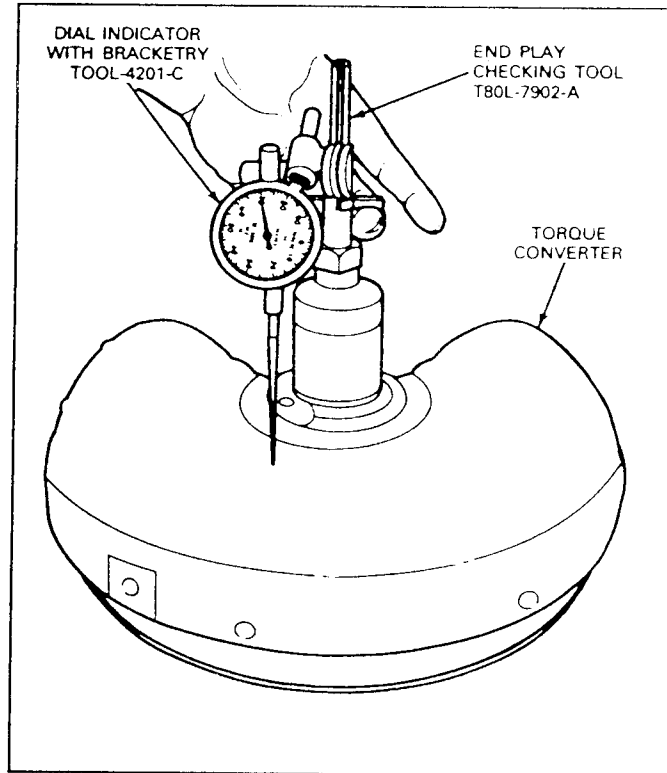

FIG. 33 Checking Stator and Turbine End Play

end play which the turbine and stator share. Replace the converter unit if the total end play exceeds the limits. End play specifications are listed at the end in the specifications section of this Section.

5. Loosen the threaded inner post to free the tool, and then remove the tool from the converter.

Converter One-Way Clutch Check

1. Insert the one way clutch holding Tool T77L-7902-R (Fig. 34), in one of the grooves in the stator thrust washer.
2. Insert the one way clutch torquing Tool, (T77L-7902-B) in the converter pump drive hub so as to engage the one way clutch inner race, (Fig. 34).
3. Attach a torque wrench to the one way clutch torquing tool. With the one way clutch holding tool held stationary, turn the torque wrench counterclockwise. The converter one way clutch should lockup and hold a 14 N·m (10 ft-lbs) force. The converter one way clutch should rotate freely in a clockwise direction. Try the clutch for lockup and hold in at least five different locations around the converter.
4. If the clutch fails to lock up and hold at 14 N·m (10 ft-lbs) torque, replace the converter unit.

Converter Damper/Hub Weld Check—AOD Only

Refer Fig. 35.

1. Position the holding fixture Tool T83L-7902-A3 in a vise and clamp tight.
2. Place the converter on top of the holding fixture aligning the pilot hub and one stud in the appropriate holes.

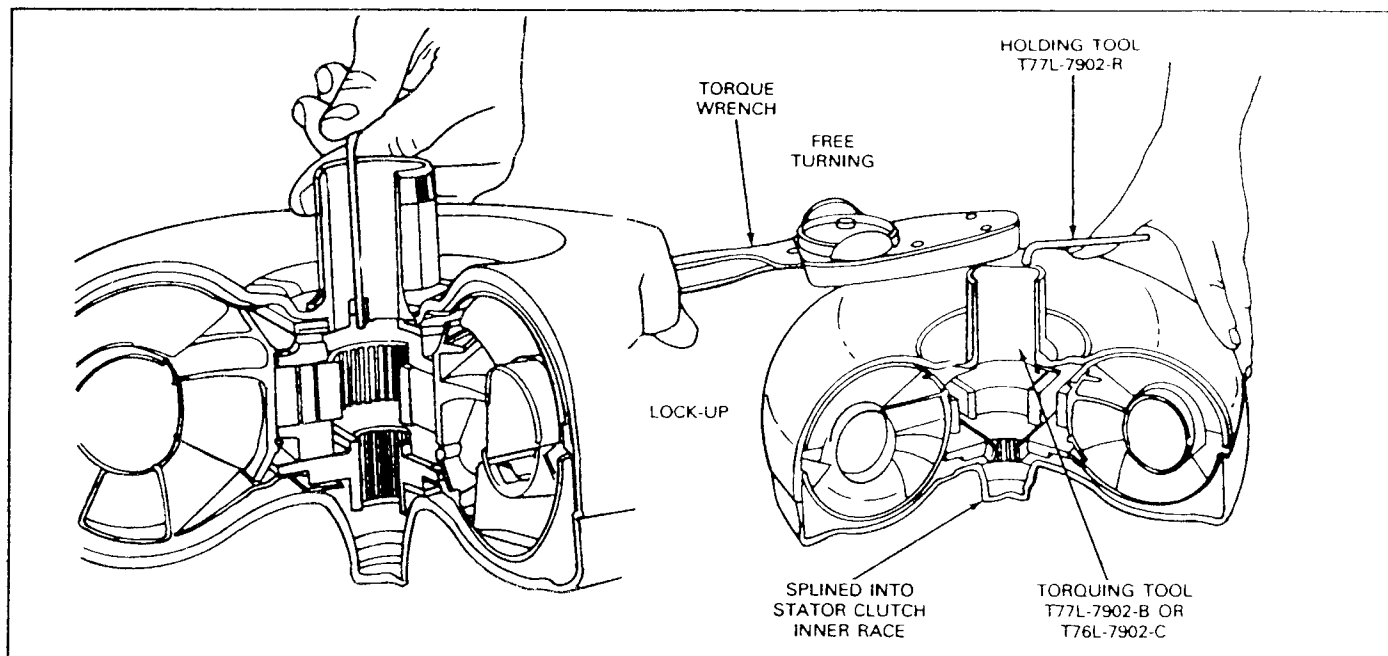

FIG. 34 Checking Converter One-Way Clutch

3. Spline the torque adapter turning Tool T83L-7902-A1 into the converter, making sure the splines engage the damper assembly.
4. Install the pilot guide Tool T83L-7902-A2 over the torque adapter turning tool and onto the impeller hub.
5. HOLD the converter snug to the holding fixture with one hand when applying torque.
6. Turn the shaft clockwise and counterclockwise applying approximately 67 N·m (50 ft-lbs) torque with a 3/4 inch drive socket and torque wrench.
7. The shaft should not turn more than two degrees.
8. If there is a grinding noise and/or if the shaft turns more than two degrees, the converter damper assembly, welds, rivets, or reaction hub are broken. Replace the torque converter.

Stator to Impeller Interference Check

1. Position the front pump assembly on a bench with the spline end of the stator shaft pointing up (Fig. 36).
2. Mount a converter on the pump with the splines on the one-way clutch inner race engaging the mating splines of the stator support. The converter hub will then engage the pump drive gear.
3. Hold the pump stationary and try to rotate the converter counterclockwise. The converter should rotate freely without any signs of interference or scraping within the converter assembly.
4. If there is an indication of scraping, the trailing edges of the stator blades may be interfering with the leading edges of the impeller blades. In such cases, replace the converter.

Stator to Turbine Interference Check—C6 and AOD Converters

1. Position the converter on the bench front side down.

2. Install a front pump assembly to engage the mating splines of the stator support and stator, and pump drive gear lugs.
3. Install the input shaft, engaging the splines with the turbine hub (Fig. 37).
4. Hold the pump stationary and attempt to rotate the turbine with the input shaft. The turbine should rotate freely in both directions without any signs of interference or scraping noise.
5. If interference exists, the stator front thrust washer may be worn, allowing the stator to hit the turbine. In such cases, the converter must be replaced.

Check the converter crankshaft pilot for nicks or damaged surfaces that could cause interference when installing the converter into the crankshaft. Check the converter front pump drive hub for nicks or sharp edges that would damage the pump seal.

Pinion Carriers

C6 and AOD

Individual parts of the planet carriers are not serviceable.

1. Check the pins and shafts in the planet assemblies for loose fit and/or complete disengagement. Use a new planet assembly if either condition exists. Before installing a planet assembly, the shaft retaining pins should be checked for adequate staking. If necessary, restake the pins before installation. When restaking, the retaining pins must not be driven into the carrier any further than 1.01mm (0.040 inch) below the surface of the carrier.
2. Inspect the pinion gears for damaged or excessively worn teeth.
3. Check for free rotation of the pinion gears.

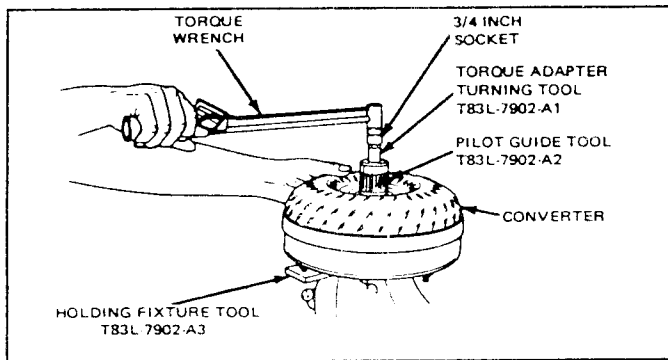

FIG. 35 Converter Damper/Hub Weld Check—AOD

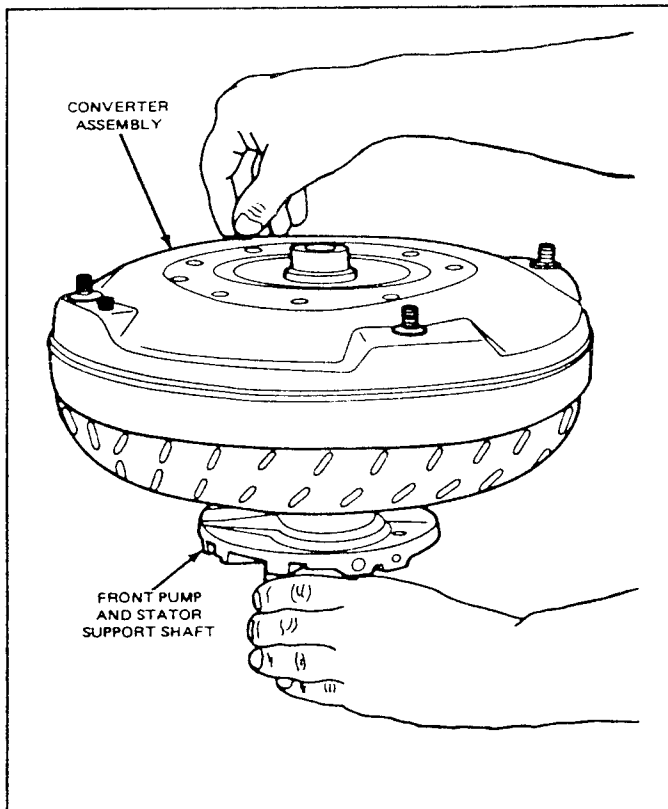

FIG. 36 Stator to Impeller Interference Check

Stator Support

C6 and AOD

1. Inspect the stator support splines for burrs and wear.
2. Check the oil ring grooves in the stator support for nicks, burrs or damaged edges.
3. Check the front and rear bushings of the stator support for wear or scoring.

Case

Inspect the case for cracks and stripped threads. Inspect the gasket surfaces and mating surfaces for burrs. Check the vent for obstructions, and check all fluid passages for obstructions and leakage (Figs. 15, 16 and 17).

Inspect the case bushing for scores. Check all parking linkage parts for wear or damage.

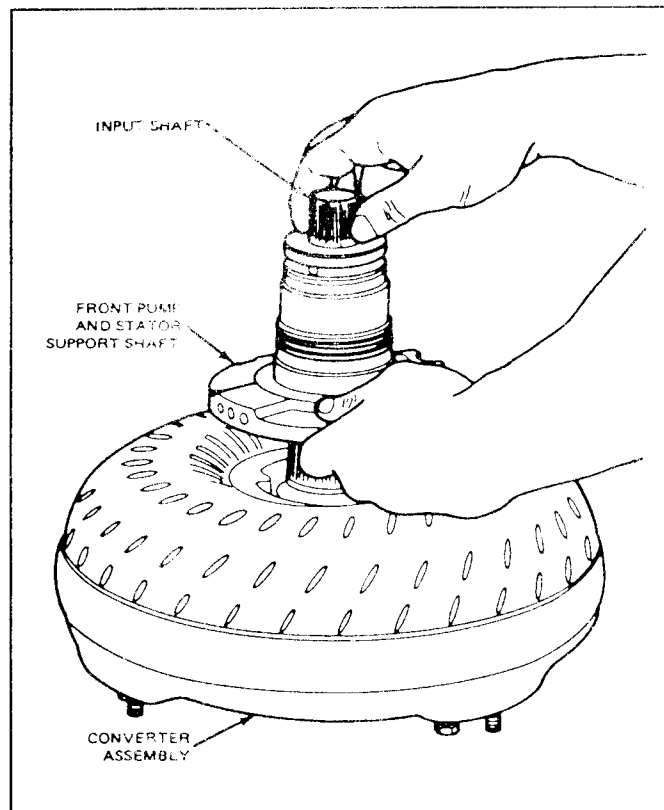

FIG. 37 Stator to Turbine Interference Check—C6 and AOD

If a transmission case thread is damaged, service kits may be purchased from local jobbers. To repair a damaged thread, the following procedures should be carefully followed.

1. Drill out the damaged threads **using the same drill size as the thread outside diameter**. For example, use a 5/16 inch drill for a 5/16-18 thread.
2. Select the proper special tap and tap the drilled hole. The tap is marked for the size of the thread being repaired. Thus, the special tap marked 5/16-18 will not cut the same thread as a standard 5/16-18 tap. The tap cuts a thread large enough to accommodate the insert, and after the insert is installed, the original thread size (5/16-18) is restored.
3. Select the proper coil inserting tool. These tools are marked with the thread size being repaired. Place the insert on the tool and adjust the sleeve to the length of the insert being used. Press the insert against the face of the tapped hole. Turn the tool clockwise and wind the insert into the hole until the insert is 1/2 turn below the face.
4. Working through the insert, bend the insert tang straight up and down until it breaks off at the notch.
5. Improperly installed inserts can be removed with the extractor tool. Place the extractor tool in the insert with the blade resting against the top coil 1/4 to 1/2 turn away from the end of the coil. Tap the tool sharply with a hammer until the blade cuts into the insert. Exert downward pressure on the tool and turn counterclockwise until the insert is removed.



SPECIFICATIONS

VACUUM DIAPHRAGM ASSEMBLY SPECIFICATION

Transmission Type	Diaphragm Type	Diaphragm Part No.	Identification	Throttle Valve Rod #		
				Part No. (7A380)	Length	Identification
C6	HAD	D7AP-7A337-AA	Part No. Stamped	C4AP-A	1.677-1.667	No Color
	SAD	D70P-7A377-BA	1 Green Stripe	D1AP-BA	1.727-1.717	Purple Daub
	SAD	D4TP-7A377-BA	1 Black Stripe	D3AP-DA	1.611-1.601	Yellow Daub
	SAD	D5AP-7A377-AA	1 Purple Stripe	D3AP-EA	1.644-1.634	Blue Daub
				D3AP-FA	1.660-1.650	Green Daub
				D3AP-GA	1.710-1.700	White Daub
				D8AP-AA	1.694-1.684	Brown Daub

Selective fit rods

SAD — Single Area Diaphragm

S-SAD — Super Single Area Diaphragm

HAD — High Altitude Diaphragm

AUTOMATIC TRANSMISSION REFILL CAPACITY — C5, C6 AND AOD AUTOMATIC TRANSMISSION

Vehicle	Transmission Type	Engine	Approximate Refill Capacity (1)		
			U.S. Quarts	Imperial Quarts	Liters
E-150 — E-250 — E-350	C6(2)	4.9L (300 CID) I-6 5.0L (302 CID) V-8 5.8L (351 CID) V-8 7.5L (460 CID) V-8 6.9L Diesel	11-3/4	9.4	11.2
F-150 — F-250 — F-350 (4x2)	C6(2)	4.9L (300 CID) I-6 5.0L (302 CID) V-8 5.8L (351 CID) V-8 7.5L (460 CID) V-8 6.9L Diesel	11-3/4	9.4	11.2
F-150 — F-250 — F-350 (4x4)	C6(2)	4.9L (300 CID) I-6 5.0L (302 CID) V-8 5.8L (351 CID) V-8 7.5L (460 CID) V-8 6.9L Diesel	13-1/2	10.8	12.7
Bronco (4x4)	C6(2)	4.9L (300 CID) I-6 5.0L (302 CID) V-8 5.8L (351 CID) V-8	13-1/2	10.8	12.7
E-150 — E-250 F-150 — F-250 (4x2) (4x4) Bronco (4x4)	AOD(2)	5.0L (302 CID) V-8 4.9L (300 CID) I-6	12.3	10.2	11.6

① Approximate dry capacity, includes cooler and lines. Fluid level indicator should be used to determine actual fluid requirements and fluid specifications. Check level at normal operating temperature. **DO NOT OVERFILL.**

If it is necessary to add or replace fluids, use only fluids which have been certified by the supplier as meeting one of the Ford Motor Company specifications shown below:

② Use Automatic Fluid-Motocraft MERCON® Multi-Purpose Transmission Fluid XT-2-QDX or DDX (ESP-M2C166-H).



Technical Service Information

TORQUE-CONVERTER END-PLAY

Transmission Model	Converter End-Play			
	New or Rebuilt Converter		Used Converter	
	mm	Inch	mm	Inch
C6	0.533 Max.	0.021 Max.	1.01 Max.	0.040 Max.
AOD (Automatic Overdrive)	0.584 Max.	0.023 Max.	1.25 Max.	0.050 Max.

STALL SPEED SPECIFICATIONS

Vehicle Application	Engine Disp.	Transmission Type	Converter Size	Stall Speed	
				Min.	Max.
F150/250/350 E150/250/350 Bronco	4.9L	C6	12"	1616	1871
F150/250 E150/250 Bronco	5.0L	C6	12"	1616	1871
F150/250/350 E150/250/350 Bronco	5.8L	C6	12"	1569	1729
F-250/350 E-250/350	7.3L	C6	12"	1715	1966
F-250/350 E-250/350	7.5L	C6	12"	1610	1891
E-Series	4.9L EFI	AOD	12"	2042	2351
F-Series	4.9L EFI	AOD	12"	2042	2351
F-Series/Bronco (4x2, 4x4)	5.0L EFI	AOD	12"	2092	2443
E-Series	5.0L EFI	AOD	12"	2092	2443

SPECIAL SERVICE TOOLS

Tool Number	Description
Tool-4201-C	Dial Indicator with Bracketry
Tool-7000-DD	Rubber Tip For Air Nozzle
Tool-7000-DE	Air Nozzle Assembly
T82L-7006-A	Air Pressure Check Plate
T82P-7006-C	Cap Screws for Air Pressure Check Plate
T76L-7902-C	Converter Clutch Torquing Tool
T77L-7902-R	Converter Clutch Holding Tool
T77L-7902-B	Converter Clutch Torquing Tool
T80L-7902-A	Torque Converter End Play Checking Tool
T83L-7902-A	Converter Checking Tool Kit
T83L-7902-A1	Torque Adapter Turning Tool
T83L-7902-A2	Pilot Guide
T83L-7902-A3	Holding Fixture
T80L-77030-B	Servo Piston Remover
T83T-7B200-AH	VRV (Vacuum Regulator Valve) Adjustment Gage Block — C6

ROTUNDA EQUIPMENT

Model	Description
014-00028	Torque Converter Cleaner
021-00054	Torque Converter Leak Tester
014-00737	Automatic Transmission Tester
021-00014	Vacuum Tester
059-00008	Vacuum and Pressure Tester



Shift Control Linkage

VEHICLE APPLICATION

Bronco, E-150—E-350, F-150—F-350 (4x2) (4x4), and F-Super Duty Chassis Cab and Motor Home Chassis, Vehicles Equipped with Automatic Transmissions.

DESCRIPTION AND OPERATION

The transmission shift control linkage transfers the selected transmission operating mode from the selector lever to the transmission. The indicated transmission position on the steering column is transferred to a shift lever on the bottom of the steering column. The shift rod transfers this position through the bell crank assembly to the control rod. The control rod transfers the indicated position to the transmission assembly.

For information on the steering column, refer to Section 13-06, Steering Column-Shift Rod within Tube.

DIAGNOSIS AND TESTING

Refer to pages 33 thru 61

ADJUSTMENTS

Perform the transmission control linkage adjustments in the order in which they appear in this Section of the manual.

Automatic Transmission Manual Linkage Adjustments

1. With the engine stopped and the parking brake applied, place the transmission selector lever at the steering column in the D (DRIVE position) for C6 applications and in the ⊕ (OVERDRIVE position) for AOD applications, and hold against the D or ⊕ stop by applying an eight pound weight to the selector lever knob.
2. Loosen the shift rod adjusting nut at point A (Figs. 1-7).
3. Shift the manual lever at the transmission into the D (DRIVE) position or ⊕ (OVERDRIVE) position,

by moving the lever all the way rearward, then forward two detents.

4. With the selector lever and transmission manual lever in the D or ⊕ position, tighten the nut at point A to 17-24 N·m (12-18 ft-lbs) torque (Figs. 1-7). Use care to prevent motion between the stud and rod.
5. Remove the eight pound weight from the steering column selector lever knob.
6. Operate the shift lever in all positions to make certain that the manual lever at the transmission is in full detent in all gear ranges. Re-adjust the linkage if required.
7. On F-150—F-250—F-350, F-Super Duty Chassis Cab, Motor Home Chassis and Bronco, recheck for correct operation of the automatic transmission selector indicator (PRND21) or (PRN⊕D1).

Under no circumstances will it be permissible to adjust linkage in any position other than the D position for C6 applications and ⊕ position for AOD applications.

Neutral Start Switch Adjustment—C6

1. Apply the parking brake.
2. With the automatic transmission linkage properly adjusted, loosen the two switch attaching bolts (Fig. 8).
3. Place the transmission selector lever in neutral. Rotate the switch and insert the gauge pin (No. 43 drill shank end) into the gauge pin holes of the switch. The gauge pin has to be inserted a full 12.303mm (31/64 inch) into the three holes of the switch (Fig. 8).
4. Tighten the two neutral start switch attaching bolts to 6.2-8.4 N·m (55-75 in-lbs). Remove the gauge pin from the switch.
5. Check the operation of the switch. The back-up lamps should come on when the transmission is in reverse. The vehicle should start only with the transmission lever in PARK or NEUTRAL.

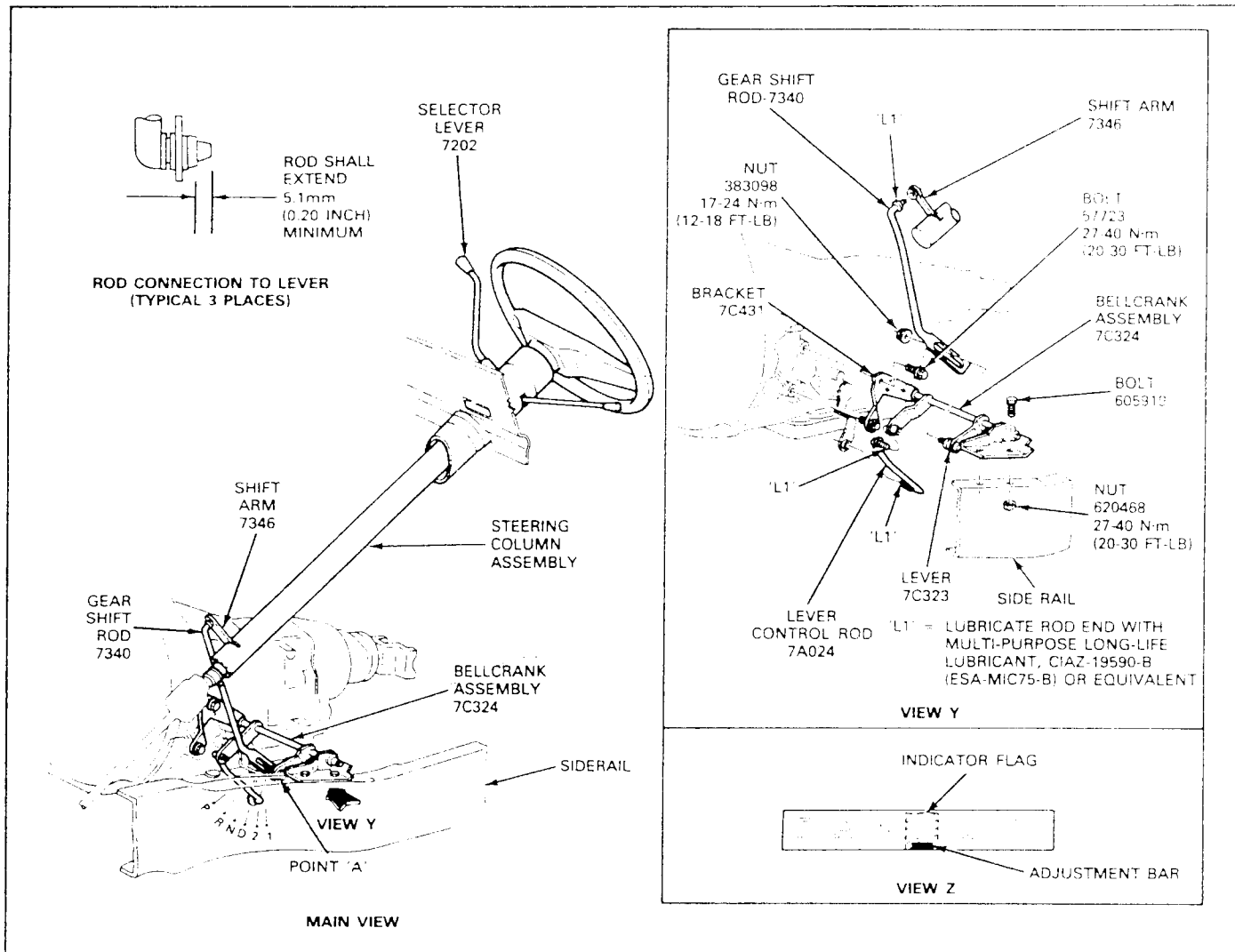

FIG. 1 C6 Automatic Transmission—Shift Linkage Adjustment—F-150—F-350, Bronco

REMOVAL AND INSTALLATION

Manual Shift Linkage Grommet

The automatic transmission linkage systems make use of a polyurethane plastic grommet to connect the various rods, levers and adjusting stud. Whenever a rod is disconnected from a grommet type connector, the old grommet must be removed and a new one installed. Remove and install the grommet as follows:

1. Place the lower jaw of the Shift Linkage Insulation Tool, T67P-7341-A or equivalent between the lever and the rod (Fig. 9). For areas with limited space, use Shift Linkage Grommet Remover, T84P-7341-A or equivalent for removal of the grommet (Fig. 10). Position the stop pin against the end of the control rod (Fig. 9) and force the rod out of the grommet. Remove the grommet from the lever by cutting off the large shoulder with a sharp knife. **The grommet must be removed from the lever and a new one installed each time the rod is disconnected.**
2. Adjust the stop pin to 12.70mm (1/2 inch) and coat the outside of the grommet with Long-Life Lubricant, C1AZ-19590-BA (ESA-M1C75-B) or equivalent. Place a new grommet on the stop pin

and force it into the lever hole. Turn the grommet several times to be sure it is properly seated.

3. Readjust the stop pin to the height shown in Fig. 9. The pin height is determined by the length of the rod end which is to be installed into the grommet. If the pin height is not adjusted, the rod may be pushed too far through the grommet causing damage to the grommet retaining lip.

NOTE: Coat ends of rods with D4AZ-19590-A, Linkage Lube or equivalent before installing in new grommet.

4. With the pin height properly adjusted, position the rod on the tool and force the rod into the grommet until the groove in the rod seats on the inner retaining lip of the grommet. For areas with limited space, use Shift Linkage Grommet Replacer, T84P-7341-B or equivalent, for grommet installation (Fig. 10).

Neutral Start Switch—C6

Removal

1. Remove the downshift linkage rod return spring at the low-reverse servo cover.
2. Apply penetrating oil, Rust Penetrant and Inhibitor, D7AZ-19A501-A (ESR-M99C56-A) or equivalent to

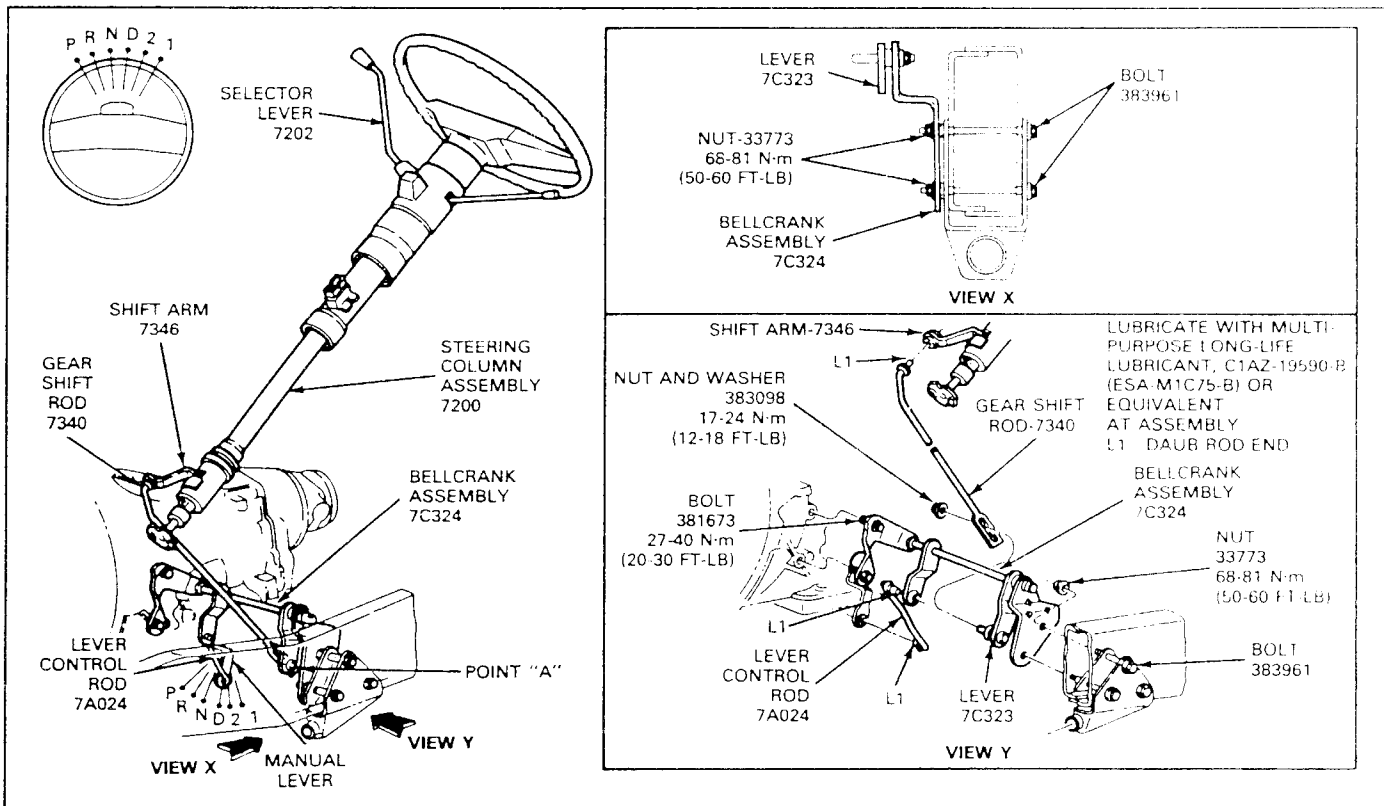

FIG. 2 C6 Automatic Transmission—Shift Linkage Adjustment—E-150—E-350

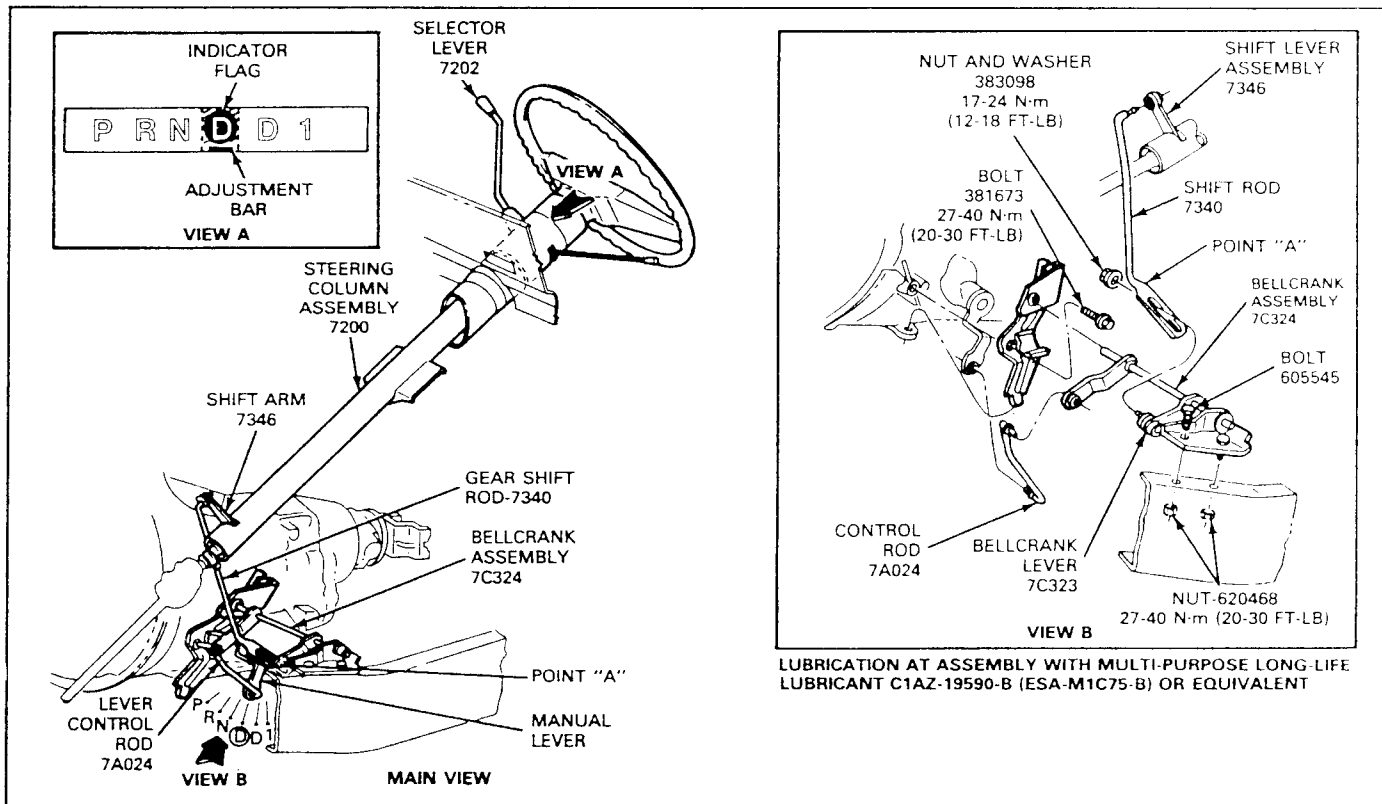

FIG. 3 Shift Linkage—Automatic Overdrive Transmission (AOD)—F-150—F-250 (4x2)

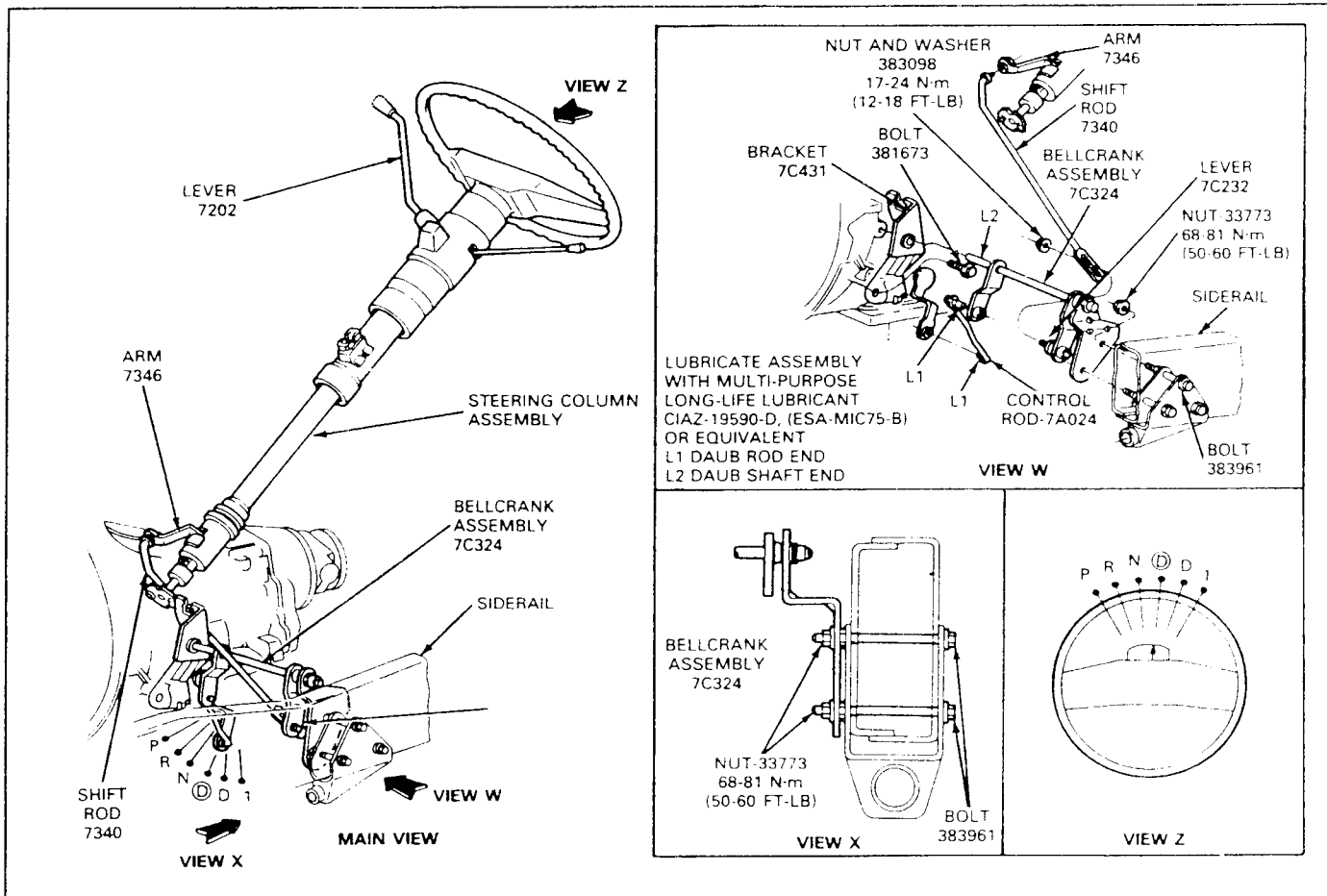

FIG. 4 Shift Linkage Automatic Overdrive Transmission (AOD)—E-150—E-250

the outer lever attaching nut to prevent breaking the inner lever shaft. Remove the transmission downshift outer lever attaching nut and lever.

3. Remove the two neutral start switch retaining bolts (Fig. 8).
4. Disconnect the two multiple wire connectors.
5. Remove the switch from the transmission.
4. Install the outer downshift lever and retaining nut, and tighten the nut. Install the downshift linkage rod return spring between the lever and retaining clip on the low-reverse servo cover.
5. Connect the wire multiple connectors. The red connector has to be inserted into the red connector and the blue connector inserted into the blue connector. Check the operation of the switch installed. The back up lamps should operate only with the transmission selector lever in REVERSE. The vehicle should start only with the transmission selector lever in PARK and NEUTRAL.

Installation

1. Install the switch on the transmission. Install the two retaining bolts.
2. With the transmission manual lever in neutral, check the location of the switch with the gauge pin. Install gauge pin (No. 43 drill) into the three gauge pin holes (Fig. 8).
3. Tighten the switch attaching bolts to 6.3-8.4 N·m (55-75 in-lbs). Remove the gauge pin.

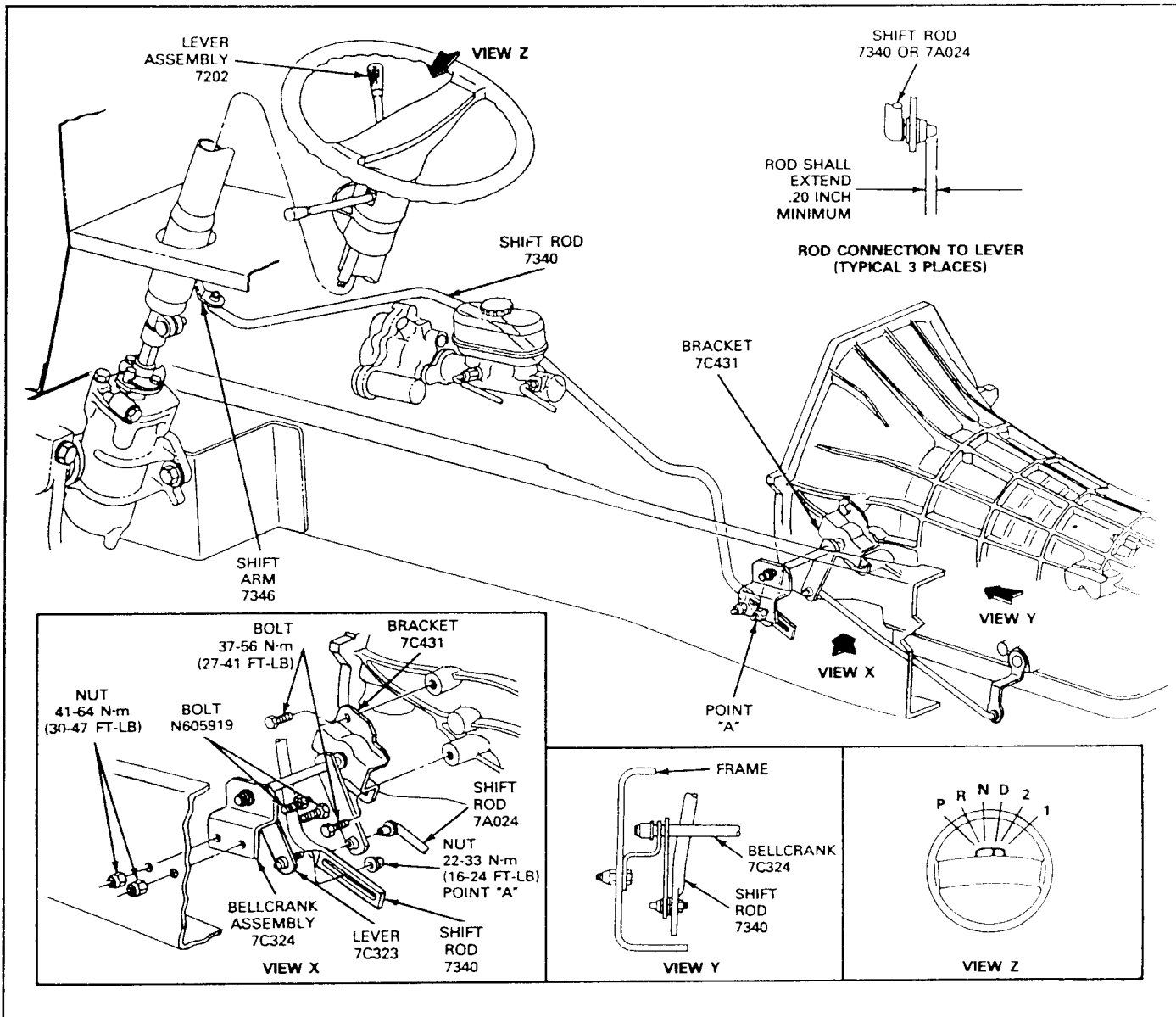

FIG. 7 E4OD Automatic Transmission—Shift Linkage Adjustment—F-Super Duty Motor Home Chassis

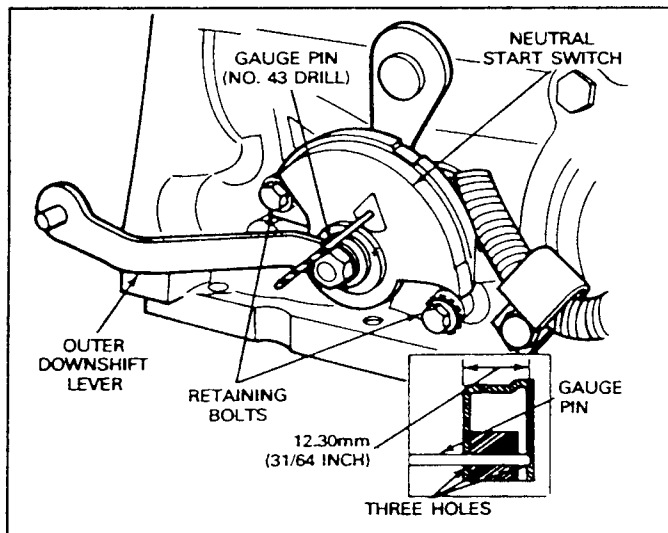

FIG. 8 Neutral Start Switch—C6

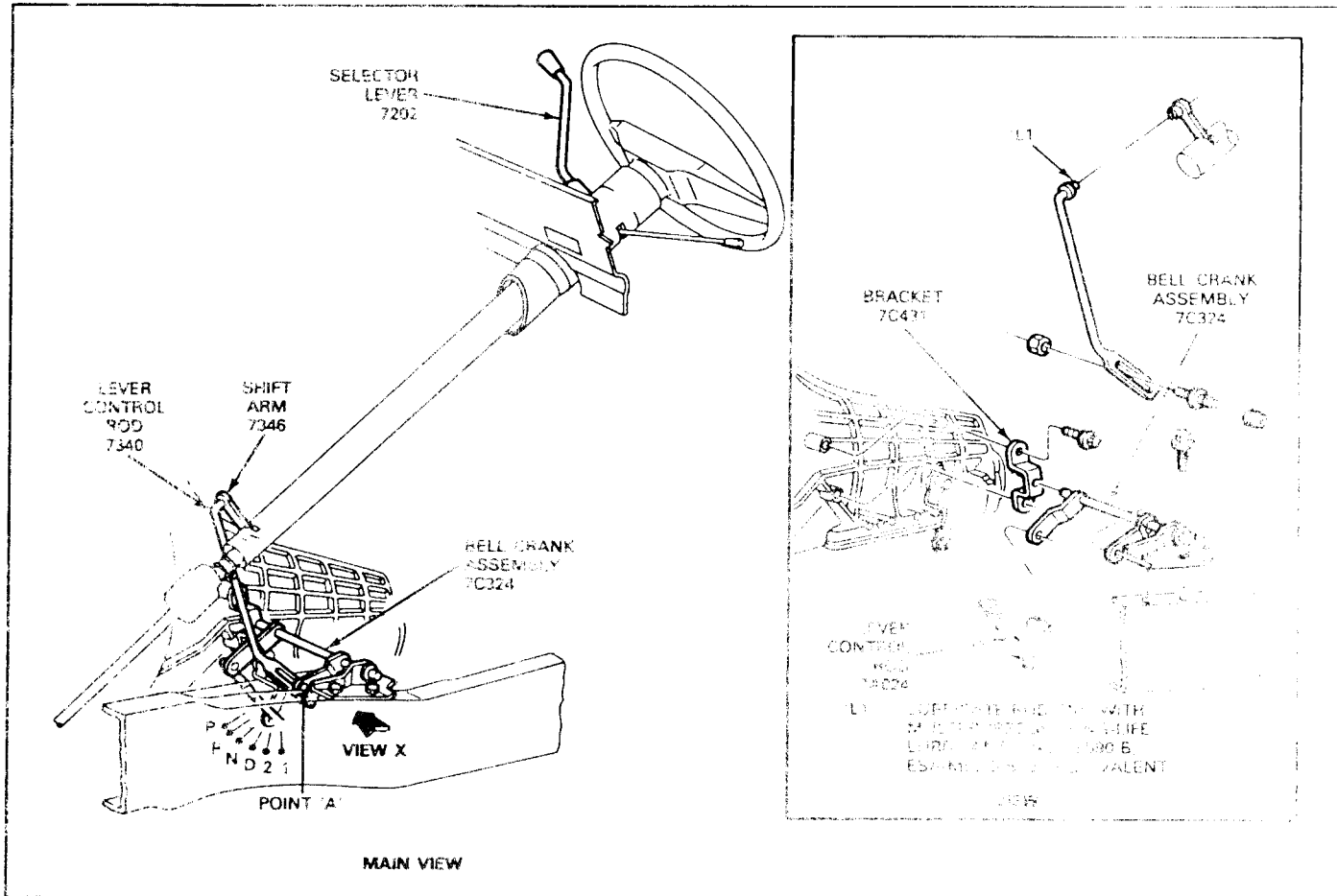

FIG. 5 E400 Automatic Transmission--Shift Linkage Adjustment--F-150--F-350, Bronco

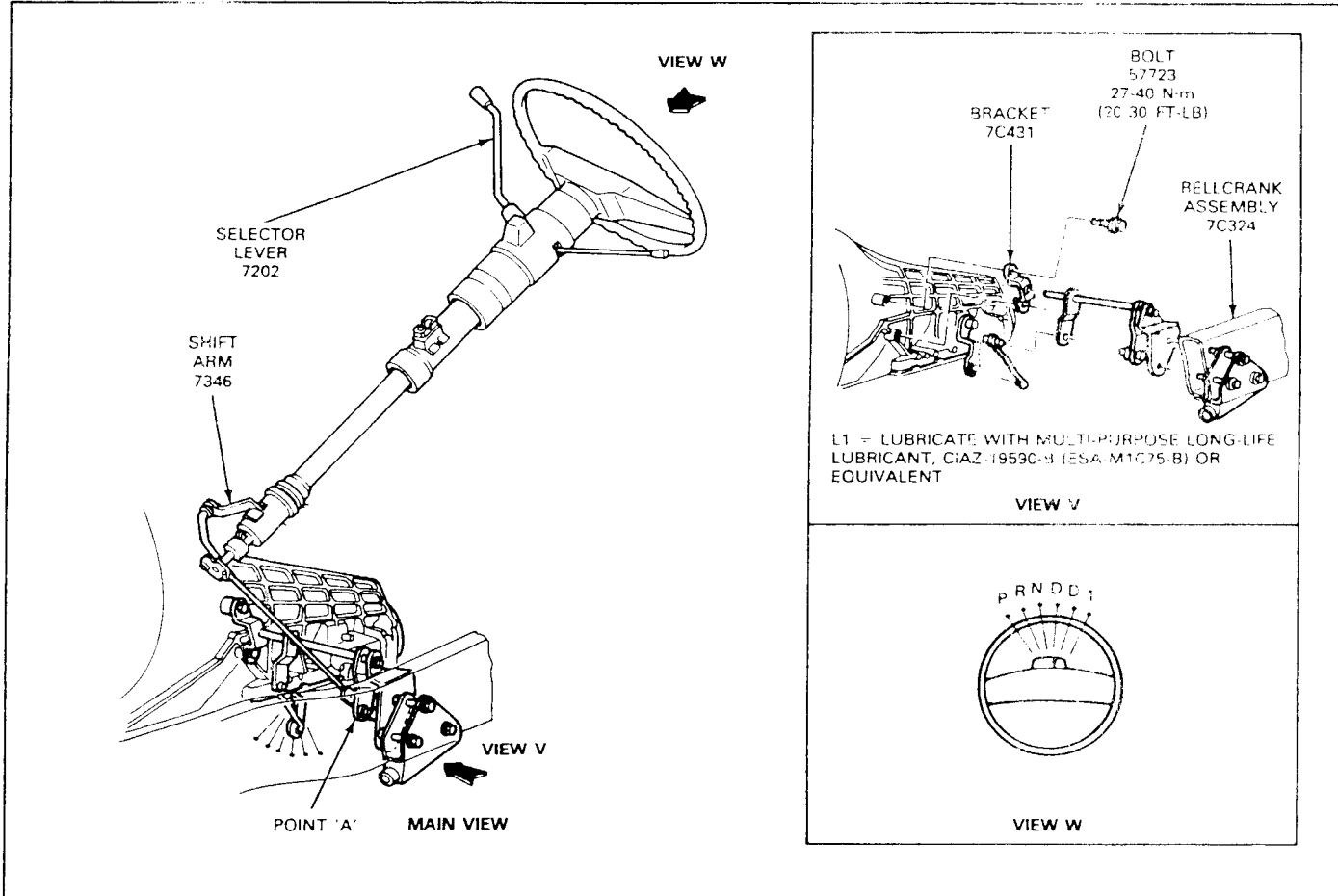

FIG. 6 E4OD Automatic Transmission—Shift Linkage Adjustment—E-150—E-350

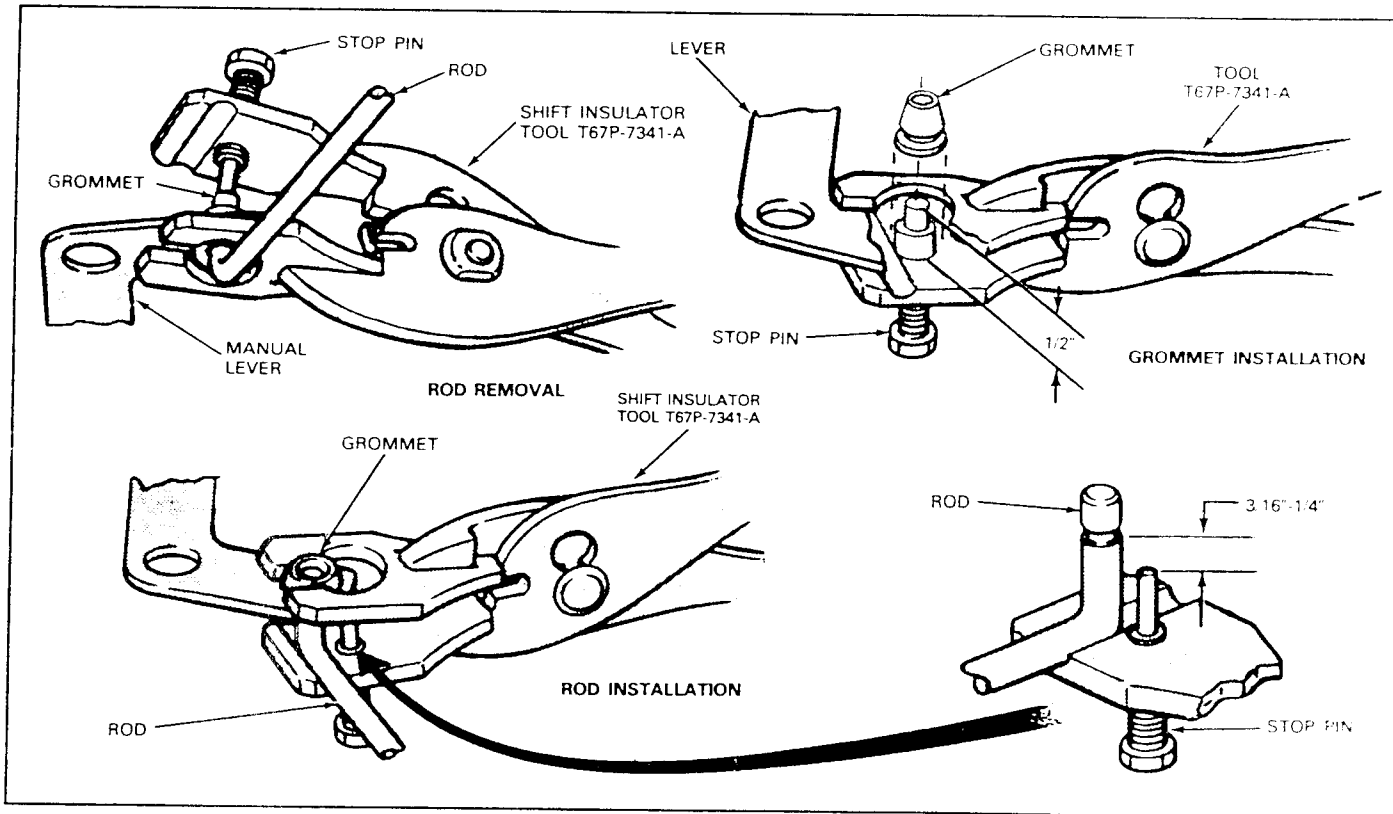

FIG. 9 Removing or Installing Shift Linkage Grommet

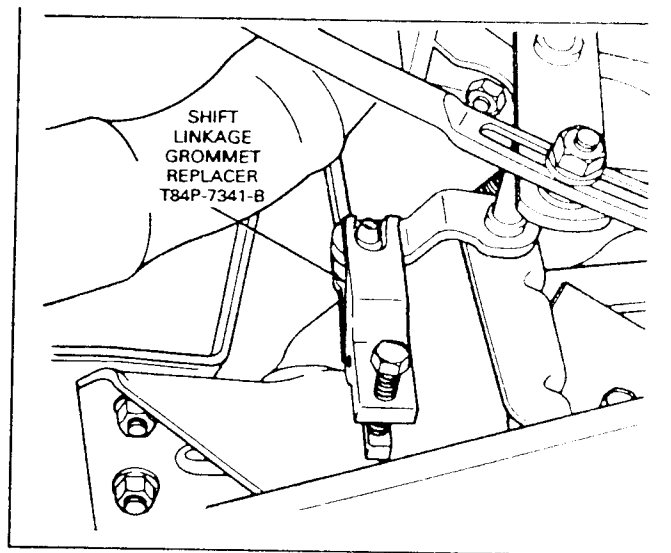
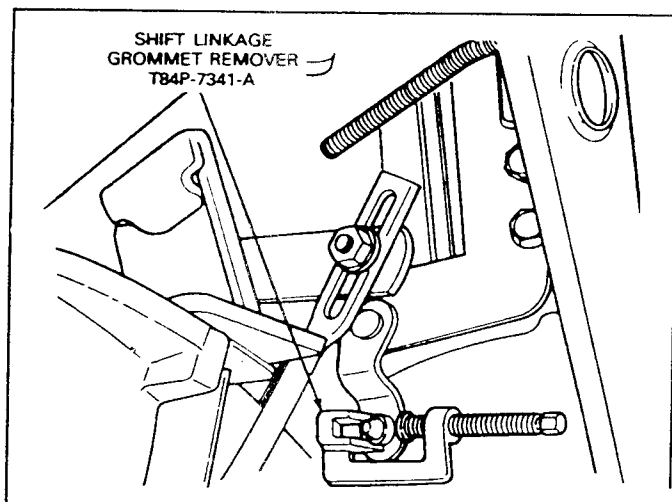

FIG. 10 Removing or Installing Shift Linkage Grommet (Limited Space Situations)

SPECIFICATIONS

TORQUE LIMITS

Description	(in-lbs)	N·m
Neutral Start Switch to Case	55-75	6.3-8.4

CD2322-1F

SPECIAL SERVICE TOOLS

SPECIAL SERVICE TOOLS

Number	Description
T67P-7341-A	Shift Linkage Insulation Tool
T74P-77247-A	Neutral Start Switch Socket Tool
T84P-7341-A	Shift Linkage Grommet Remover
T84P-7341-B	Shift Linkage Grommet Replacer



C-6 LOW ROLLER CLUTCH RACE

COMPLAINT: *Failure of # 9 thrust washer on the C-6 transmission, in heavy duty applications such as tow trucks or modified ambulances.*

CAUSE: *Lack of lube to # 9 thrust washer.*

CORRECTION: *On the back side of the overrun roller clutch inner race there is a lube hole that goes half way through the race. To get more lube to the # 9 thrust washer, drill the hole all the way through the race so it breaks out the other side. The drilling will probably blue the drill, since the race is a hardened part.*

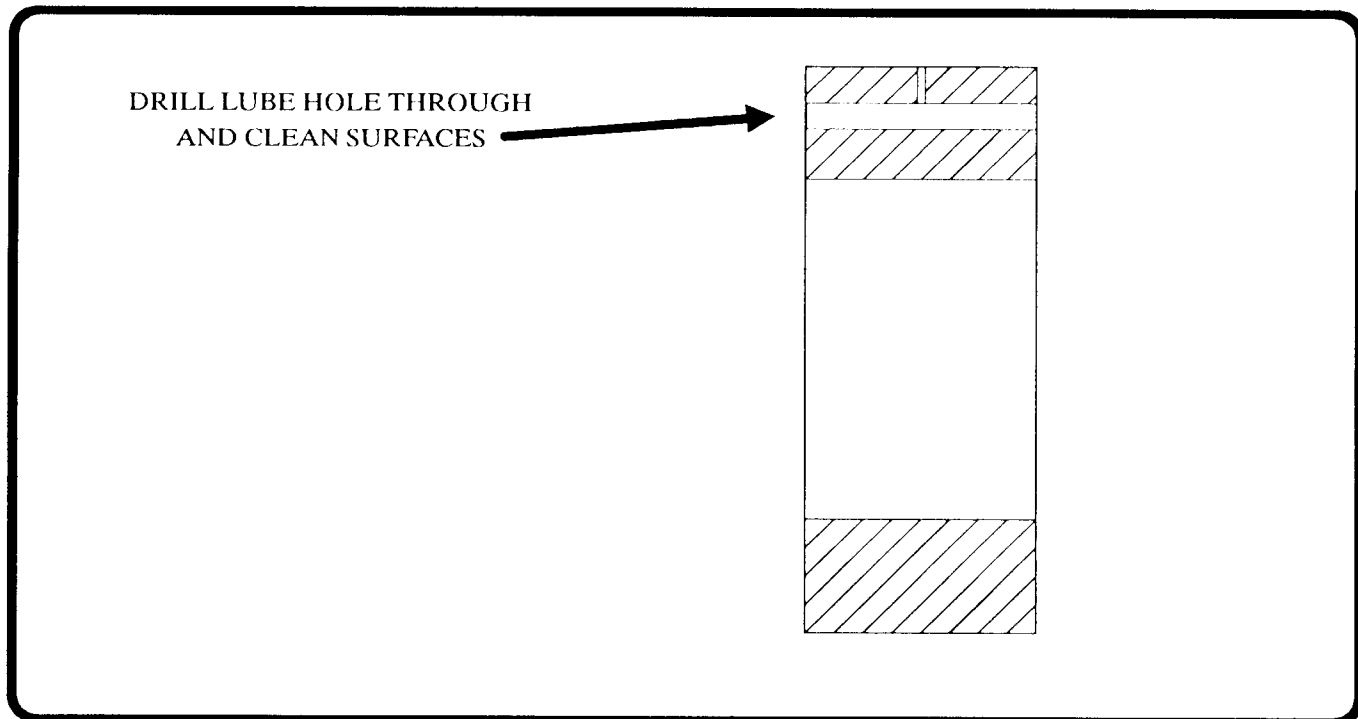

C-6 MANUAL LINKAGE ADJUSTMENT

COMPLAINT: Any complaint of delayed engagement in drive or reverse, any unexplained burn out or any shift related complaint.

CAUSE: The cause can be a bent or cracked internal detent lever.

CORRECTION: The way to check the alignment is to use an old style C-6 valve body that has the detent in the valve body. On that assembly, place the manual valve in the drive position. With the detent lever in the case, in drive, set the old style valve body on the transmission, and check that the manual valve lines up with the pin in the detent valve. If the valve and pin do not align, replace the the linkage.

