



[PREVIOUS](#)   
[MENU](#)

## INDEX

### GO TO PAGE

GENERAL INFORMATION .....	3
A/T CENTRAL UNIT .....	7
TROUBLESHOOTING-TESTING .....	13
TEARDOWN .....	29
VALVE BODY .....	42
MAINSHAFT/COUNTERSHAFT .....	50
COMPONENT TEARDOWN .....	58
REASSEMBLY .....	72
ADJUSTMENT .....	91

**AUTOMATIC TRANSMISSION SERVICE GROUP**



## INTRODUCTION

# Honda 4 Speed Computer Controlled

This manual covers the HONDA 4 speed transaxle that is computer controlled. Although it is similar to previous 4 speed units both in the fuel injection and carburetor models, there are some major differences. We have included a diagnosing section that covers both the Hydraulic and computer complaints.

We thank the HONDA MOTOR COMPANY for the information and illustrations that have made this booklet possible.

**ROBERT D. CHERRNAY**  
*TECHNICAL DIRECTOR*

**DALE ENGLAND**  
*FIELD SERVICE CONSULTANT*

**FRANK MIETUS**  
*HOTLINE TECHNICIAN*

**WAYNE COLONNA**  
*HOTLINE TECHNICIAN*

**ED KRUSE**  
*LAY OUT*

**AUTOMATIC TRANSMISSION SERVICE GROUP**  
9200 SOUTH DADELAND BLVD.  
SUITE 720  
MIAMI, FLORIDA 33156  
(305) 661-4161



# Technical Service Information

## GENERAL INFORMATION

Carbureted engine:

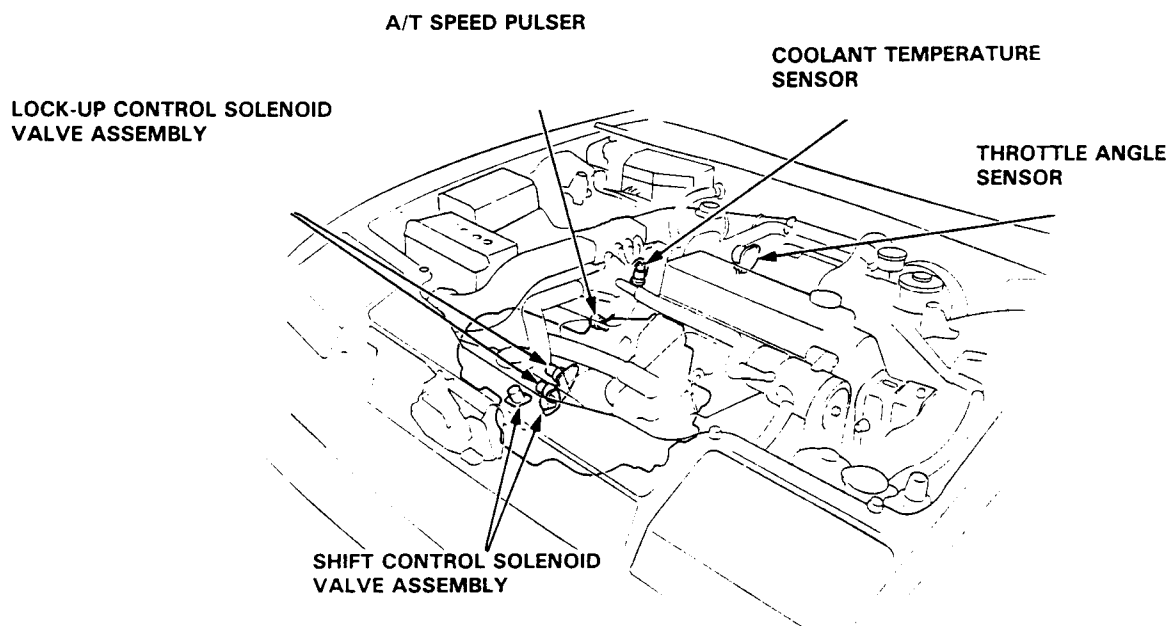
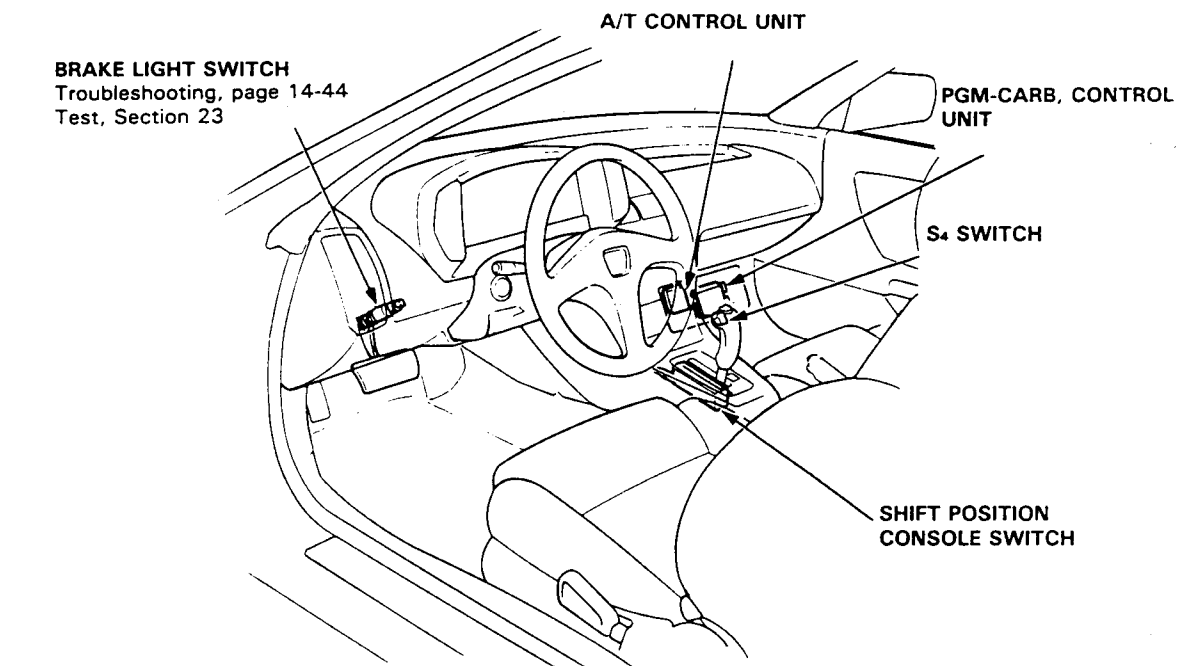

AUTOMATIC TRANSMISSION SERVICE GROUP



# Technical Service Information

Fuel-Injected engine:

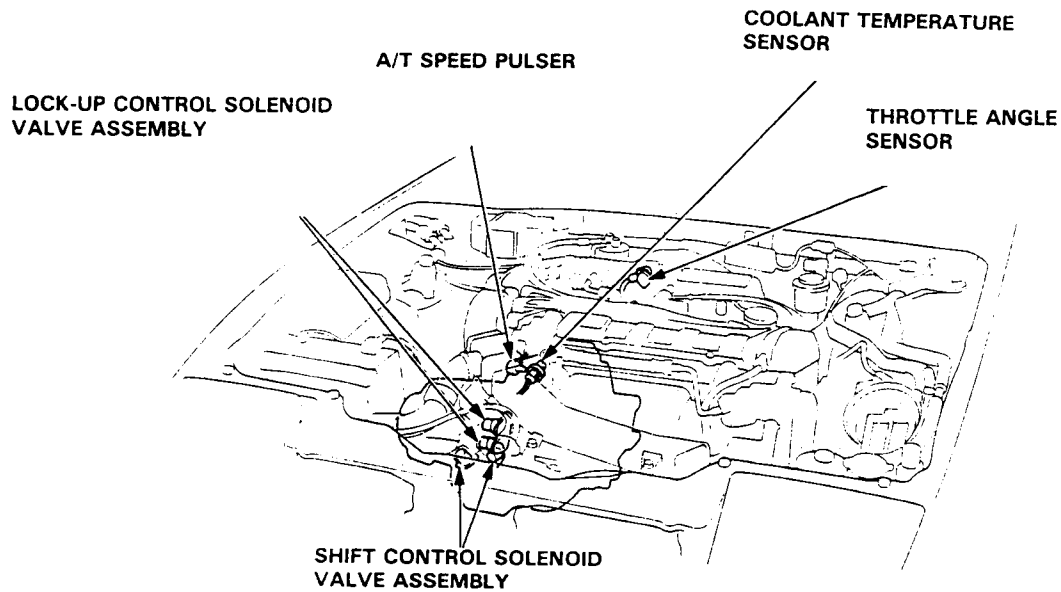
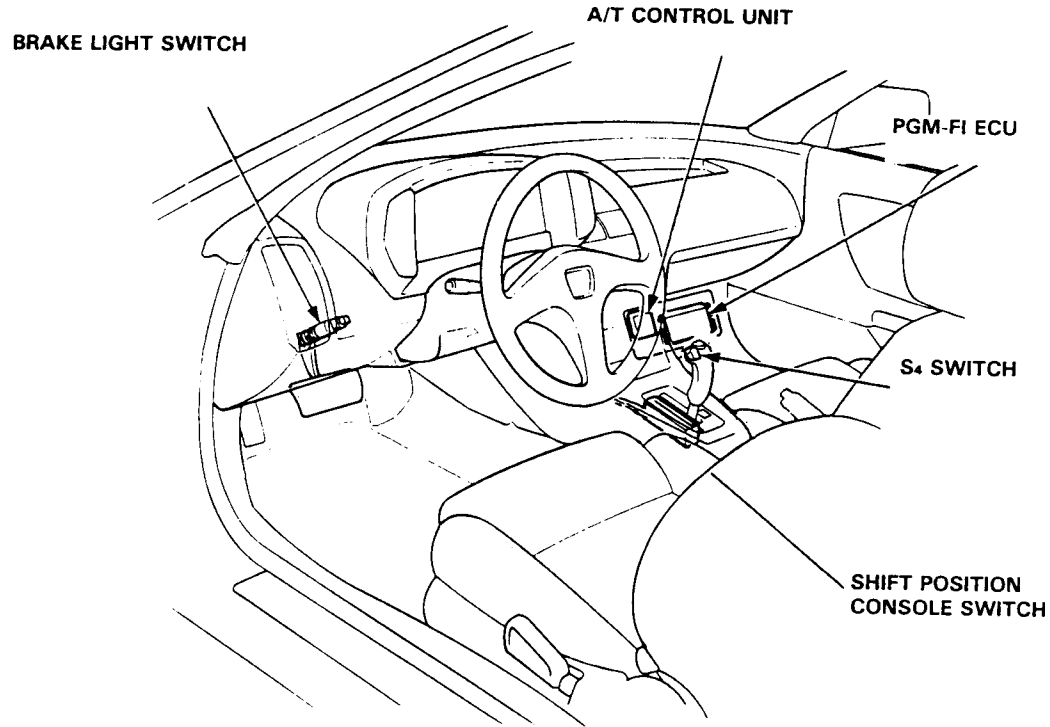

AUTOMATIC TRANSMISSION SERVICE GROUP



The Automatic Transmission is a combination of a 3-element torque converter and dual-shaft electronically controlled automatic transmission which provides 4 speeds forward and 1 speed reverse. The entire unit is positioned in line with the engine.

## **TORQUE CONVERTER, GEARS AND CLUTCHES**

The torque converter consists of a pump, turbine and stator, assembled in a single unit.

They are connected to the engine crankshaft so they turn together as a unit as the engine turns. Around the outside of the torque converter is a ring gear which meshes with the starter pinion when the engine is being started. The entire torque converter assembly serves as a flywheel while transmitting power to the transmission mainshaft.

The transmission has two parallel shafts, the mainshaft and countershaft. The mainshaft is in line with the engine crankshaft.

The mainshaft includes the clutches for 1st, and 2nd/4th, and gears for 3rd, 2nd, 4th, Reverse and 1st (3rd gear is integral with the mainshaft, while reverse gear is integral with 4th gear).

The countershaft includes 3rd clutch and gears for 3rd, and 4th, Reverse and 1st.

The 4th and reverse gears can be locked to the countershaft at its center, providing 4th gear or Reverse, depending on which way the selector is moved.

The gears on the mainshaft are in constant mesh with those on the countershaft. When certain combinations of gears in the transmission are engaged by the clutches, power is transmitted from the mainshaft to the countershaft to provide **S3**, **S4**, **D**, **2** and **R**.

## **Electronic Control**

The electronic control system consists of an automatic control unit, sensors, and 4 solenoid valves. Shifting and lock-up are electronically controlled for comfortable driving under all conditions.

The A/T control unit is located below the dash under the carpet on the passenger's side of the car.

## **HYDRAULIC CONTROL**

The valve assembly includes the main valve body, secondary valve body, servo valve body, regulator valve body and lock-up timing valve body.

They are bolted to the torque converter case as an assembly.

The main valve body contains the manual valve, 1-2 shift valve, 2-3 shift valve, 3-4 shift valve, cooler relief valve, orifice control valve, lock-up shift valve, lock-up timing valve, 2nd kickdown valve and oil pump gears.

The secondary valve body includes the clutch pressure control valve, 3rd kickdown valve, modulator valve, throttle valve B and the 2nd orifice control valve.

The servo valve body contains the accumulator pistons and throttle valve A. The regulator valve body contains pressure regulator valve and lock-up control valve. Fluid from the regulator passes through the manual valve to the various control valves.

The lock-up timing valve body contains a pressure relief valve and torque converter check valve. The 1st, 3rd and 4th clutches receive oil from their respective feed pipes.

## **SHIFT CONTROL MECHANISM**

Input from various sensors located throughout the car determines which shift control solenoid valve the A/T control unit will activate. Activating a shift control solenoid valve changes modulator pressure, causing a shift valve to move. This pressurizes a line to one of the clutches, engaging that clutch and its corresponding gear.

## **LOCK-UP MECHANISM**

In **S4** or **D**, in 2nd, 3rd and 4th, pressurized fluid is drained from the back of the torque converter through an oil passage, causing the lock-up piston to be held against the torque converter cover. As this takes place, the mainshaft rotates at the same speed as the engine crankshaft. Together with hydraulic control, an electronic control unit optimizes the timing of the lock-up mechanism.

The lock-up shift valve controls the range of lock-up according to lock-up control solenoid valves A and B, and throttle valve B. When lock-up control solenoid valves A and B activate, modulator pressure changes. Lock-up control solenoid valves A and B are mounted on the torque converter housing, and are controlled by the A/T control unit.

(cont'd)



# Technical Service Information

## GEAR SELECTION

The selector lever has six positions: **P** PARK, **R** REVERSE, **N** NEUTRAL, **D** or **S4** 1st through 4th gear ranges, **S3** 1st through 3rd gear ranges, and **2** 2nd gear.

Position	Description
<b>P</b> PARK	Front wheels locked; parking pawl engaged with parking gear on countershaft. All clutches released.
<b>R</b> REVERSE	Reverse; reverse selector engaged with countershaft reverse gear and 4th gear clutch locked.
<b>N</b> NEUTRAL	All clutches released.
<b>D</b> DRIVE	General driving; starts off in 1st, shifts automatically to 2nd, 3rd, then 4th, depending on vehicle speed and throttle position. Downshifts through 3rd, 2nd and 1st on deceleration to stop. The lock-up mechanism comes into operation in 2nd, 3rd and 4th when the transmission is in <b>D</b> and <b>S4</b> .
<b>S3</b> SPORTS (1 through 3, or 4)	For rapid acceleration at highway speeds and general driving; starts off in 1st, shifts automatically to 2nd, then 3rd ( <b>S3</b> ), and then 4th ( <b>S4</b> ) depending on vehicle speed and throttle position. Downshifts through lower gears on deceleration to stop.
<b>2</b> SECOND	For engine braking or better traction starting off on loose or slippery surfaces; stays in 2nd gear, does not shift up or down.

Starting is possible only in **P** and **N** through use of a slide-type, neutral-safety switch.

## POSITION INDICATOR

A position indicator in the instrument panel shows what gear has been selected without having to look down at the console.

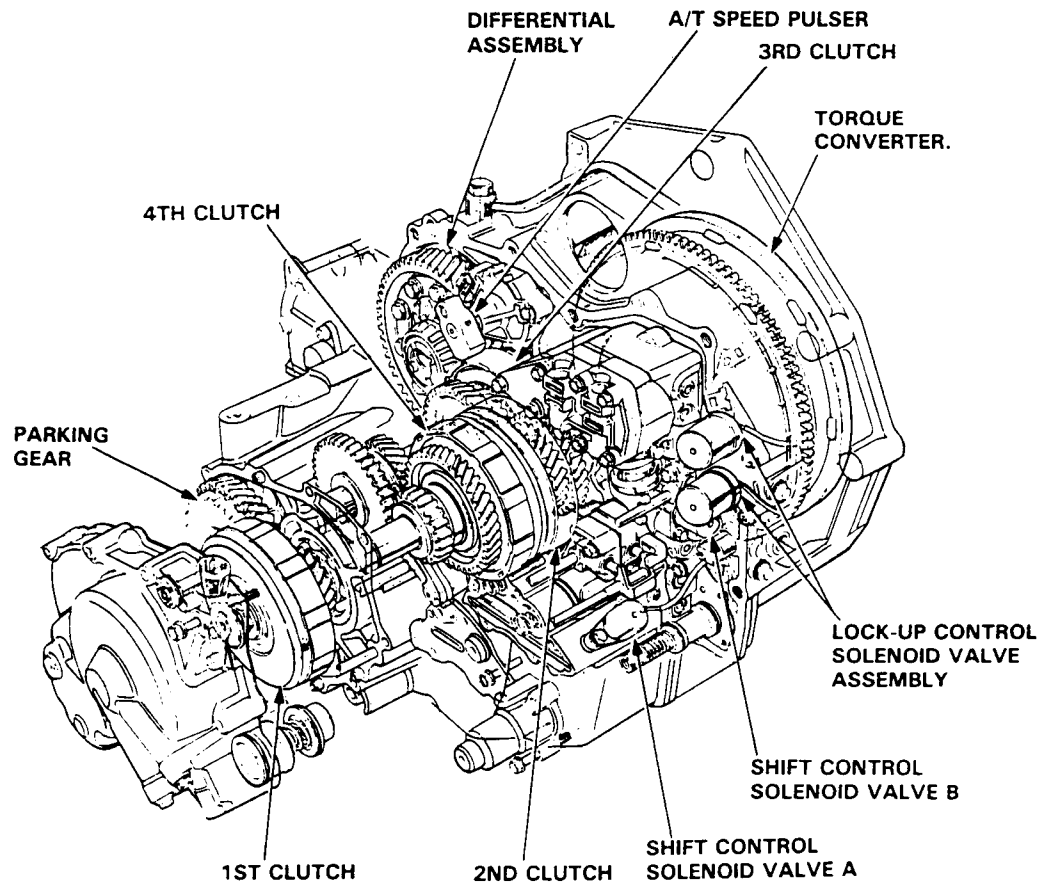

## A/T Control Unit

- From various input signals, the A/T control unit controls the shift control solenoid valves A and B and the lock-up control solenoid valves A and B.
- The A/T control unit is below the dash under the carpet on the passenger's side of the car.
- The A/T control unit has a self-diagnosis function that indicates the area of trouble with the number of blinks of the self-diagnosis indicator (LED).

[Text and illustration below are for PGM-FI model.]

- |   |  |
|---|--|
| B1: Ground  | A1: Senses R range signal  |
| B2: Power source (IG1)  | A2: Senses N range signal  |
| B3: Sends driving signal to lock-up control solenoid valve A      | A3: Senses D range signal  |
| B4: Sends driving signal to shift control solenoid valve A        | A4: Senses S range signal  |
| B5: Sends driving signal to shift control solenoid valve B        | A5: Senses 2 range signal  |
| B6: Ground  | A6: Senses signal from speed pulser  |
| B7: Power source (IG1)  | A7: Senses signal from A/T speed pulser                                      |
| B8: Sends driving signal to lock-up control solenoid valve B      | A10: Senses ignition pulse   |
| B9: Sends dimming cancel signal to S <sub>3</sub> indicator light | A11: Senses voltage signal in accordance with the engine coolant temperature |
| B11: Sends driving signal to S <sub>3</sub> indicator light       | A12: Senses ON/OFF of brake signal   |
| B12: Power source (BAT)   | A13: Senses ON/OFF of S <sub>4</sub> switch signal                           |
|   | A15: Senses standard voltage of sensors                                      |
|   | A16: Senses voltage signal in accordance with the throttle opening           |
|   | A18: Sends driving signal to S <sub>4</sub> indicator light                  |

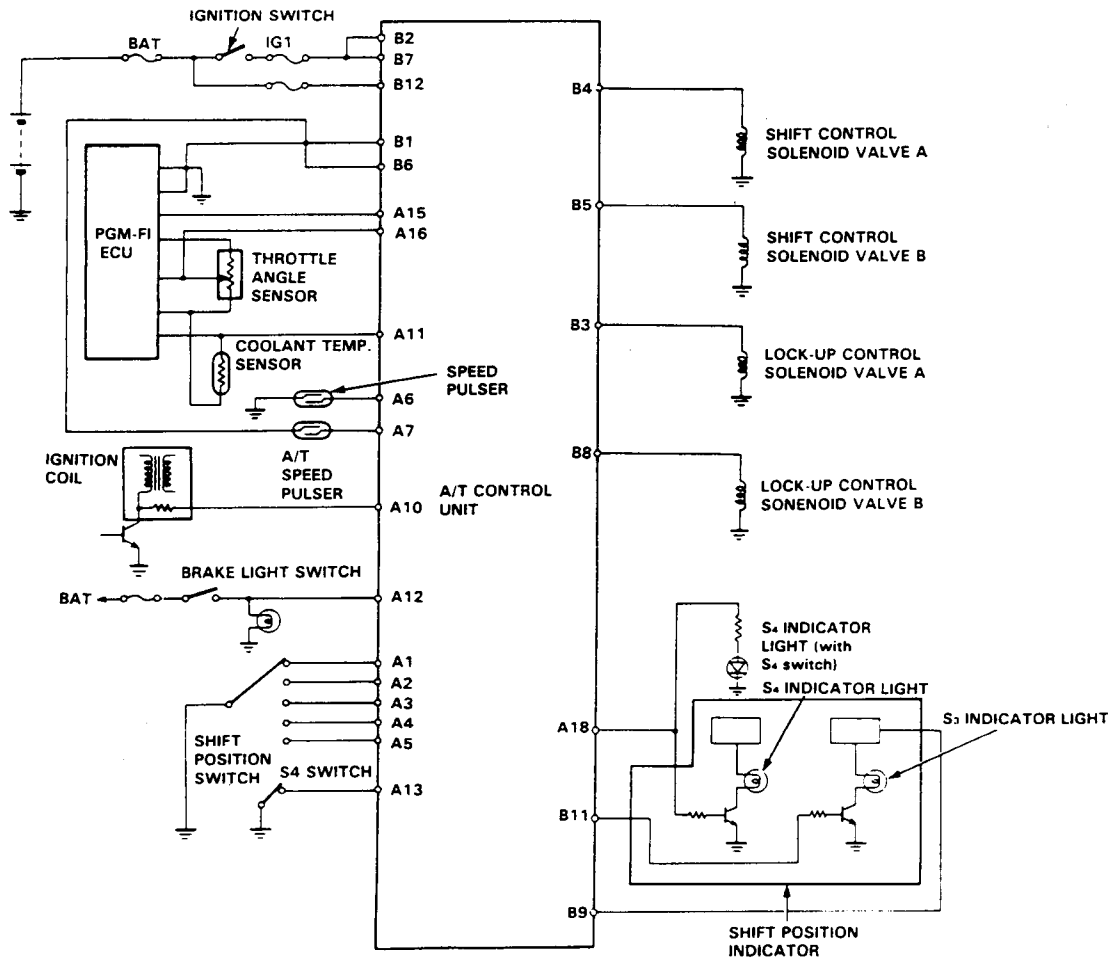

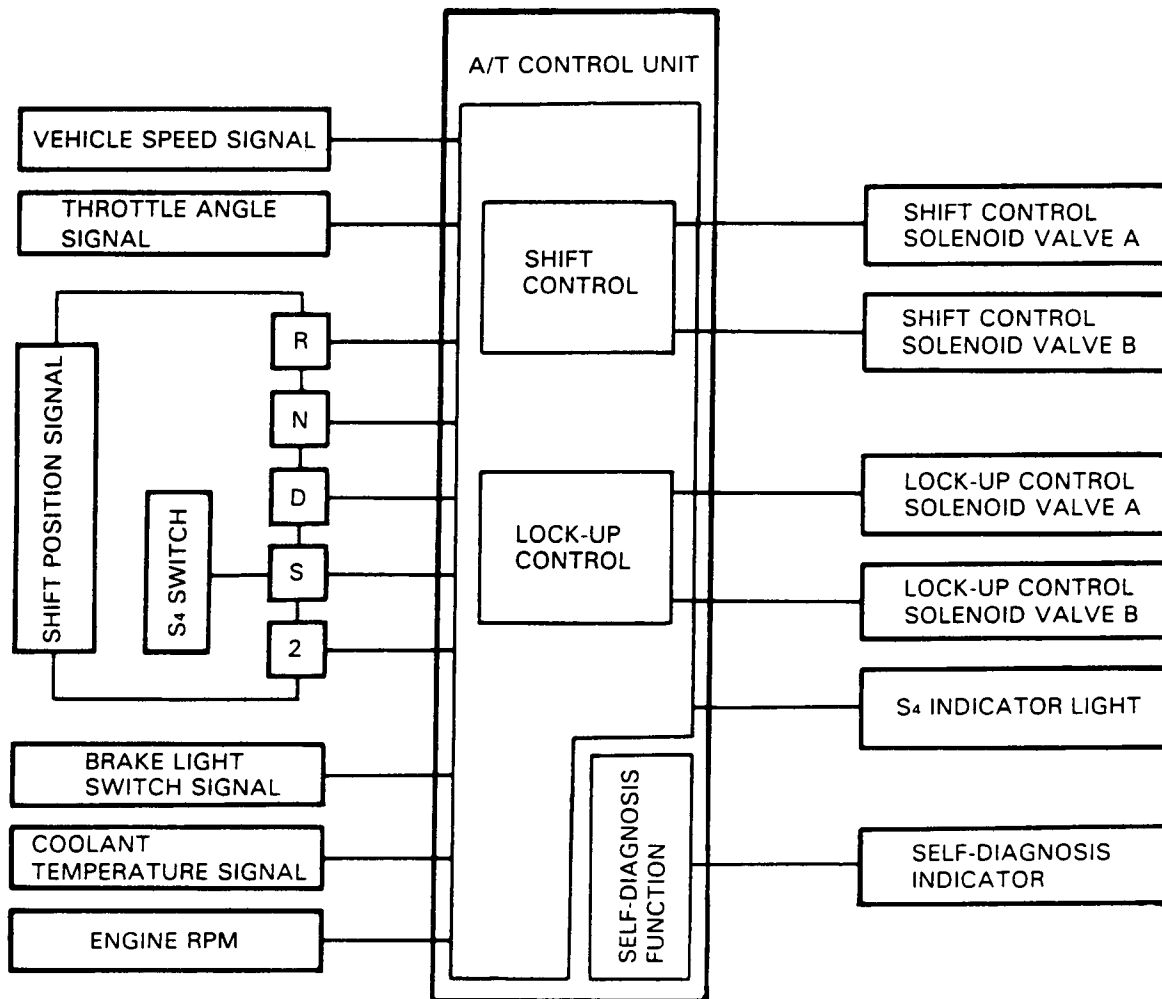
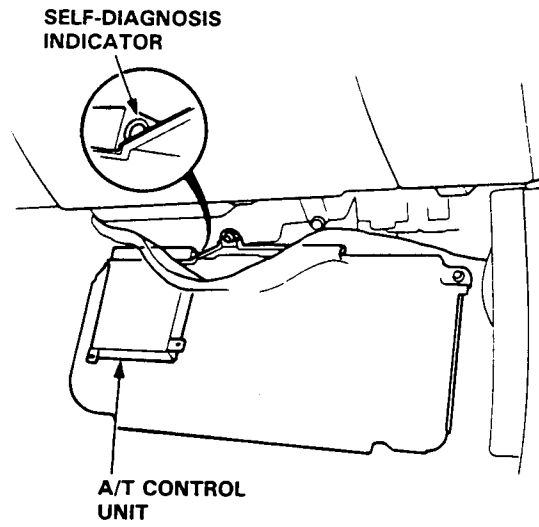



## Clutches

### [1st Clutch]

The 1st clutch is on the right end of the mainshaft. In the **S<sub>3</sub>**, **S<sub>4</sub>**, or **D** range, constant hydraulic pressure is applied to the mainshaft through the 1st clutch to the mainshaft 1st gear.

The clutch plate is mounted on the clutch drum, while the clutch disc is fitted to the mainshaft 1st gear.

The 1st gears are attached to the mainshaft and countershaft through needle bearings, one for each gear.

When select lever is placed in the **S<sub>3</sub>**, **S<sub>4</sub>**, or **D** range, hydraulic pressure is applied from the right side cover through the mainshaft, and thus to the clutch drum; as the pressure rises, the clutch piston presses the clutch plate and clutch disc, thus causing the clutch to engage.

Power is transmitted from the mainshaft 1st gear, through the countershaft 1st gear, to the one-way clutch, parking gear, and finally to the countershaft. The one-way clutch locks in the forward direction when in 1st gear. In the **S<sub>3</sub>**, **S<sub>4</sub>**, or **D** range, all others besides 1st gear are not engaged, thus transmitting no power.

### [2nd Clutch]

The 2nd clutch is right of center on the mainshaft, and is the same construction as the 1st clutch. The 2nd clutch is joined back-to-back to the 4th clutch. The mainshaft 2nd gear uses a needle bearing. The countershaft 2nd gear is splined to the countershaft.

In 2nd gear of **2**, **S<sub>3</sub>**, **S<sub>4</sub>**, or **D**, hydraulic pressure is applied to the clutch drum from the mainshaft, thus transmitting power from the mainshaft 2nd gear to the countershaft 2nd gear.

### [3rd Clutch]

The 3rd clutch is on the left end of the countershaft.

The clutch hub is jointed to the countershaft 3rd gear, on the countershaft, supported by a single needle bearing.

In 3rd gear of **S<sub>3</sub>**, **S<sub>4</sub>**, or **D**, hydraulic pressure is applied to the 3rd clutch on the countershaft, thus causing the clutch to engage, and transmitting power.

### [4th Clutch]

The 4th clutch is identical to the 2nd clutch, to which it is joined on the mainshaft. The clutch hub is joined to the mainshaft 4th gear and reverse gear, supported by two needle bearings.

In 4th gear of **S<sub>4</sub>**, or **D**, hydraulic pressure is generated within the mainshaft, applying pressure to the 4th clutch on the mainshaft.

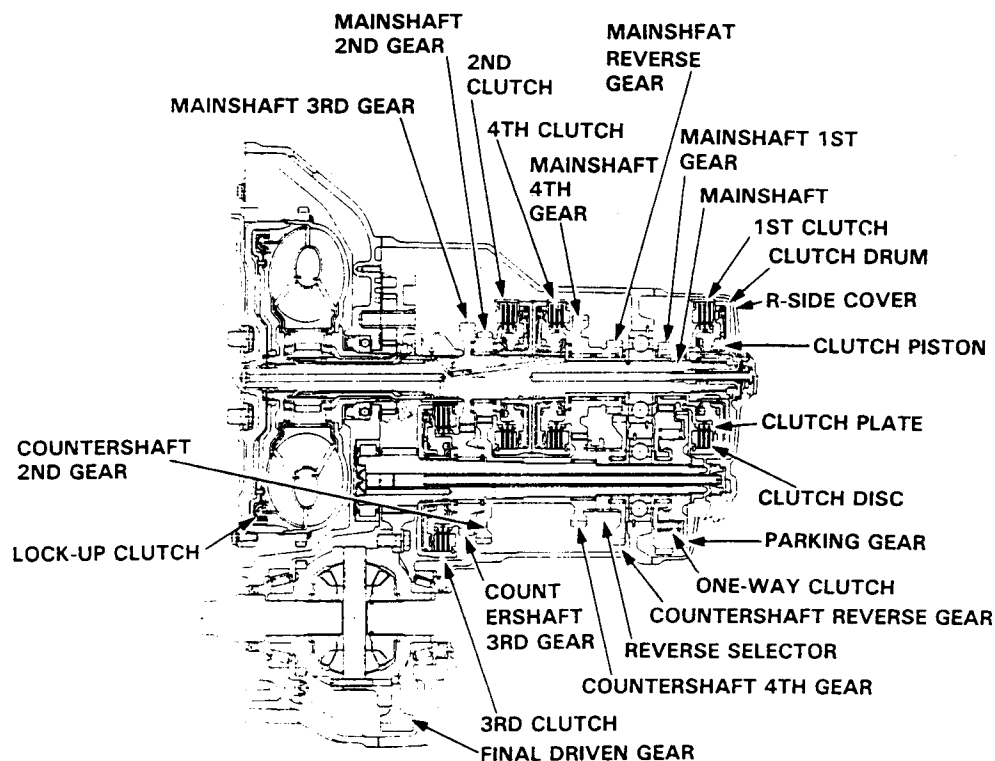



# Technical Service Information

## Power Flow

RANGE	PART	TORQUE CONVERTER	1ST GEAR 1ST CLUTCH	1ST GEAR ONE-WAY CLUTCH	2ND GEAR 2ND CLUTCH	3RD GEAR 3RD CLUTCH	4TH		REVERSE GEAR	PARKING GEAR
							GEAR	CLUTCH		
	P	○	X	X	X	X	X	X	X	○
	R	○	X	X	X	X	X	○	○	X
	N	○	X	X	X	X	X	X	X	X
S <sub>3</sub>	1ST	○	○	○	X	X	X	X	X	X
	2ND	○	*○	X	○	X	X	X	X	X
	3RD	○	*○	X	X	○	X	X	X	X
S <sub>4</sub> or D	1ST	○	○	○	X	X	X	X	X	X
	2ND	○	*○	X	○	X	X	X	X	X
	3RD	○	*○	X	X	○	X	X	X	X
	4TH	○	*○	X	X	X	○	○	X	X
2	2RD	○	X	X	○	X	X	X	X	X

○: Operates, X: Doesn't operate, \*: Although the 1st clutch engages, driving power is not transmitted as the one-way clutch slips.

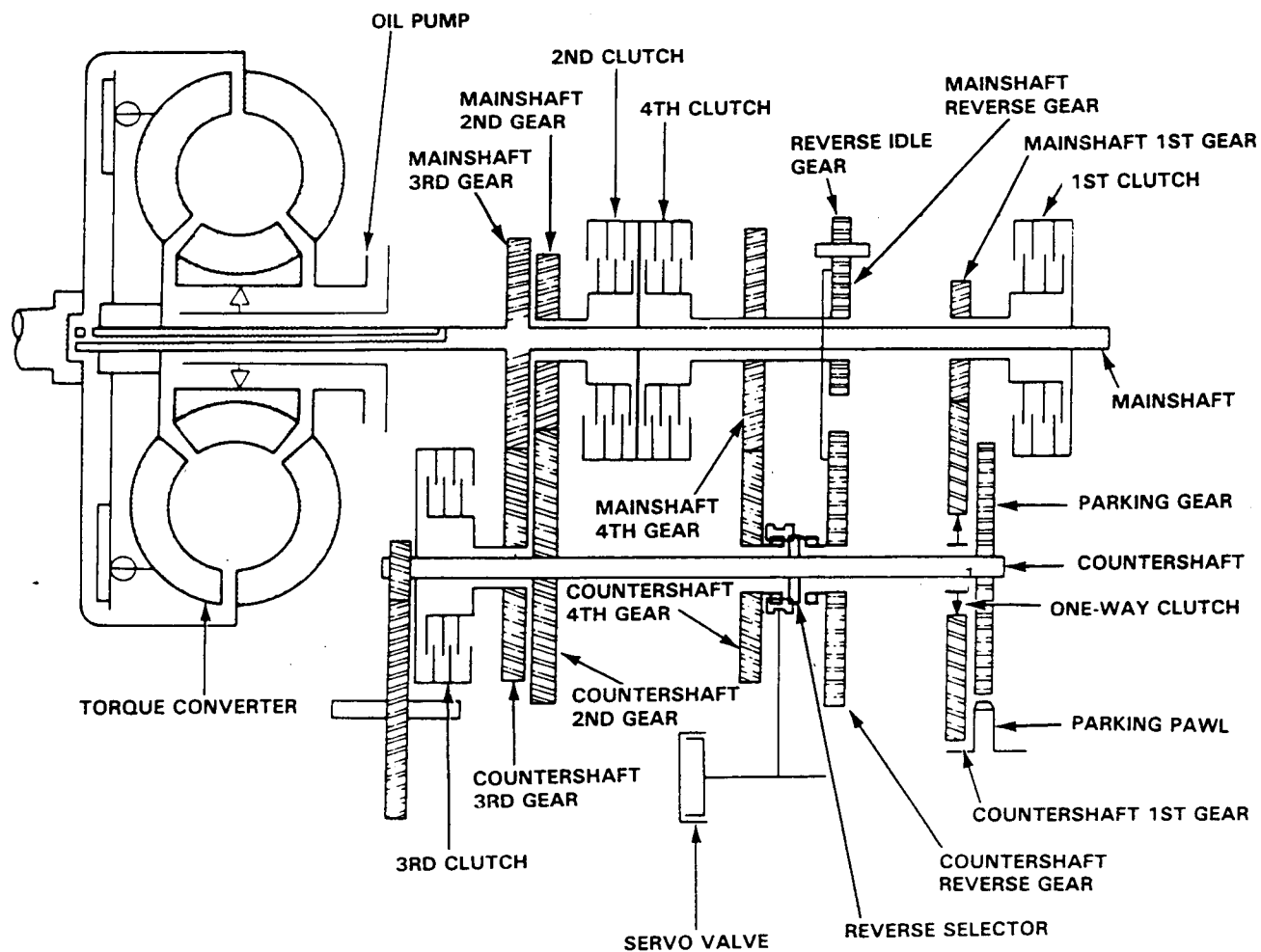



# Technical Service Information

## Hydraulic Control

In the hydraulic control unit, the regulator valve, manual valve and oil pump connected to the torque converter are unified and contained inside the valve body. The valve body includes the main valve body, the regulator valve body, the secondary valve body, the servo body, and the lock-up timing valve body.

The oil pump is driven by splines on the right end of the torque converter which is attached to the engine. Oil flows through the regulator valve, to maintain specified pressure through the main valve body to the manual valve, and servo body, directing pressure to each of the clutches.

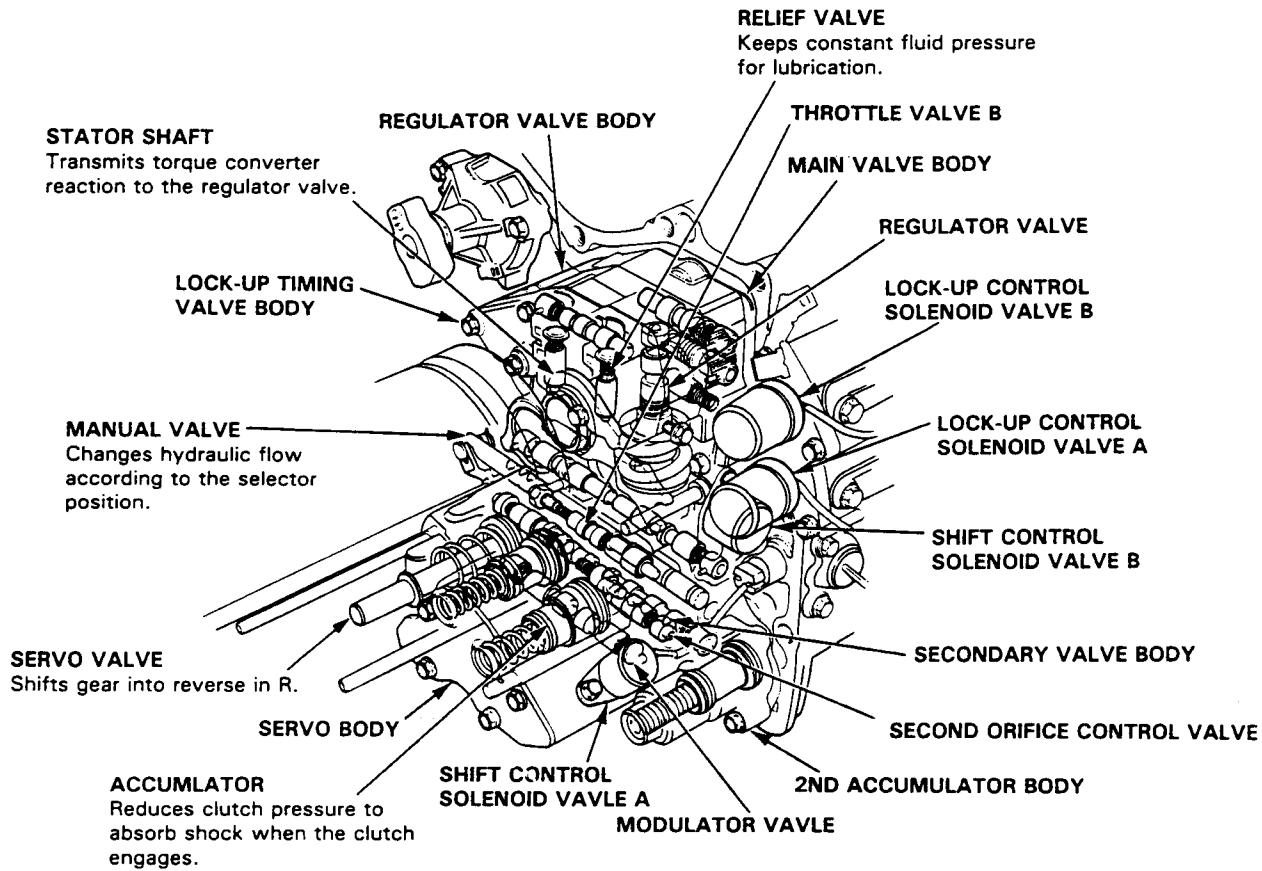

(cont'd)



# Technical Service Information

Fuel-injected engine:

Carbureted engine:

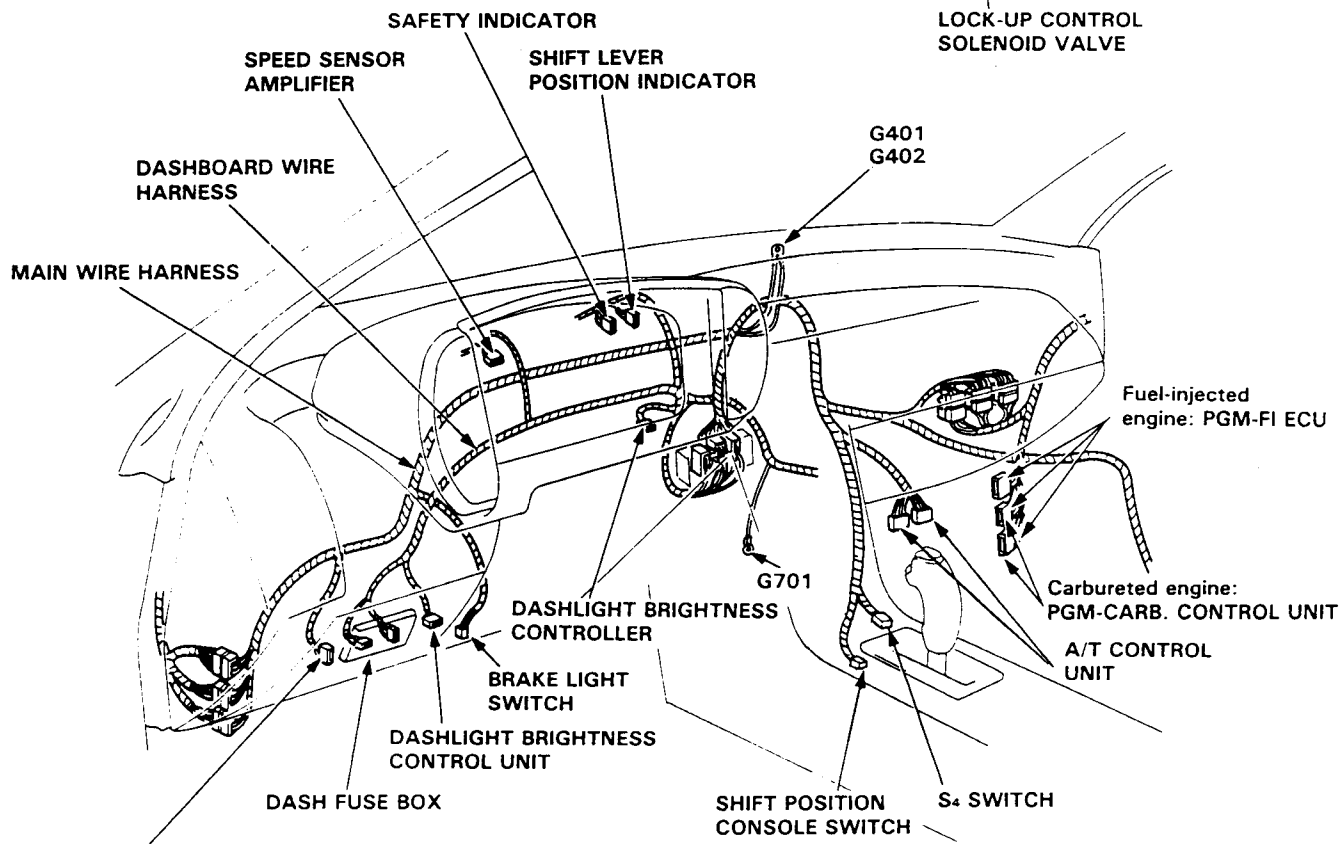
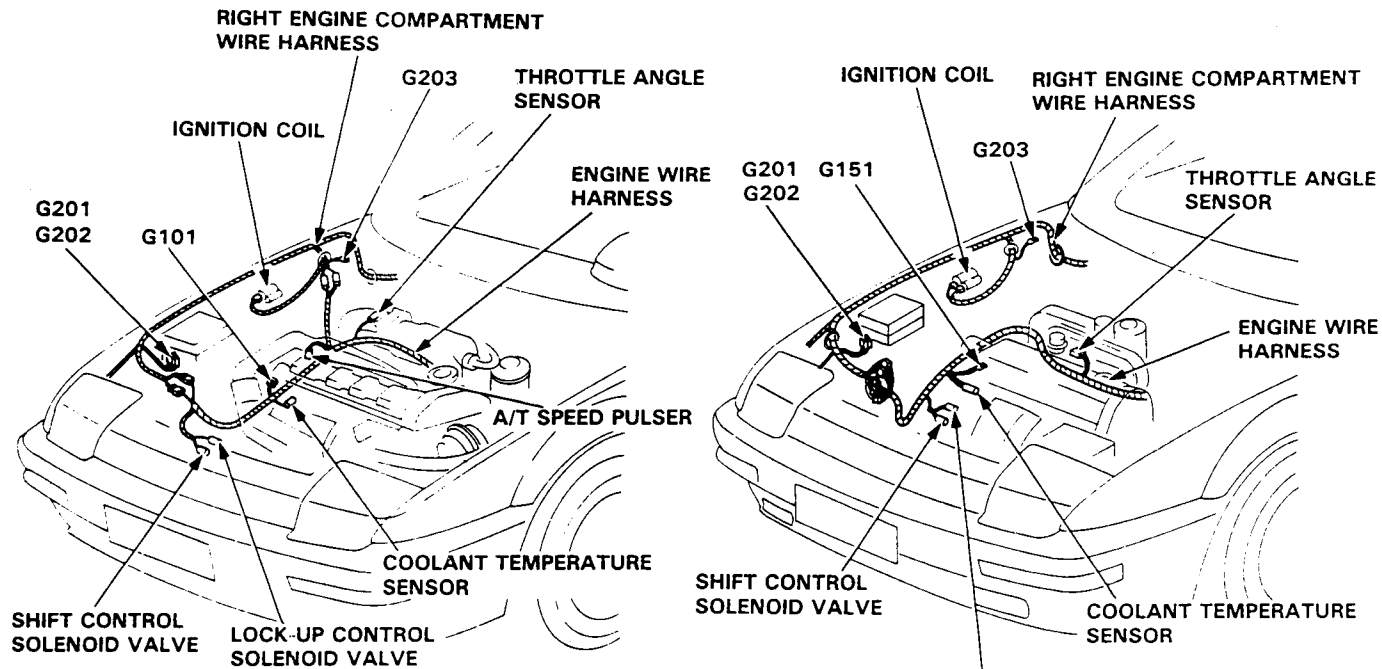

Fuel-injected engine: PGM-FI MAIN RELAY  
Carbureted engine: FUEL CUT-OFF RELAY

AUTOMATIC TRANSMISSION SERVICE GROUP

## Troubleshooting Procedures

The A/T Control Unit has a built-in self-diagnosis function. The S<sub>3</sub> indicator light in the gauge assembly and LED display on the A/T control unit blink when the A/T control unit senses an abnormality in the input or output systems. The number of blinks from the LED display varies according to the problem, which can be diagnosed by counting the number of blinks.

For problem diagnosis count the number of blinks from the LED display as shown on the Symptom-to-Component Chart on page 14-40. If no abnormality is found from your inspection, refer to the hydraulic system Symptom-to-Component Chart on page 14-66.

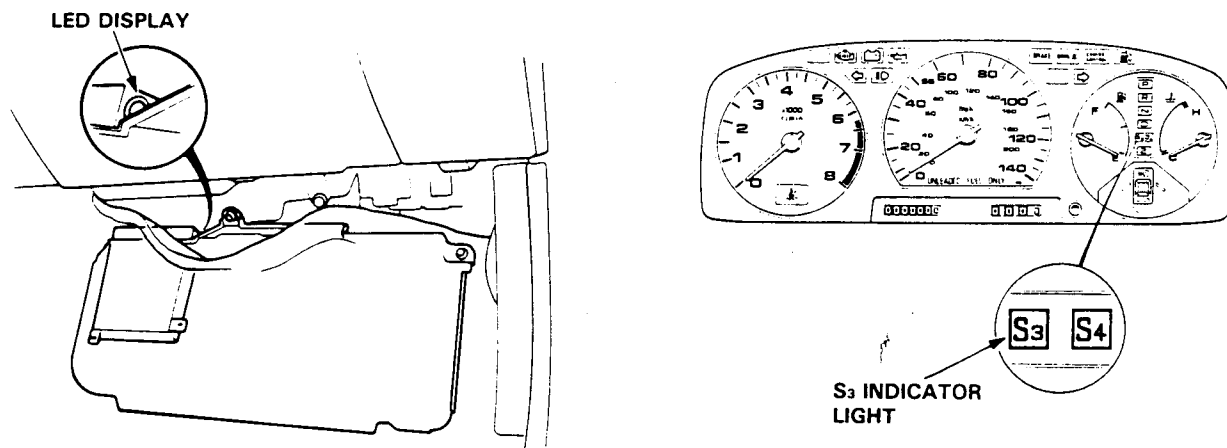

When the ignition switch is turned ON, the S<sub>3</sub> indicator light comes on for about two seconds regardless of whether there is a problem. The S<sub>3</sub> indicator light will also come on when in S<sub>3</sub> mode.

If there is a system problem, the S<sub>3</sub> indicator light will come on and continue to blink until the ignition key is turned OFF. When the ignition key is turned ON again, the S<sub>3</sub> indicator light will not blink again for the original problem. But if the A/T control unit senses the original abnormality again with ignition switch ON, the S<sub>3</sub> indicator light will blink again for the original problem. Therefore, even though the S<sub>3</sub> indicator light does not come on when turning the ignition key ON, check the LED display for automatic transmission problem diagnosis.

Since the LED problem code is retained in memory, it will blink again whenever the ignition key is turned on. If the LED problem code is not memorized, check the following causes:

- Check the EFI ECU fuse No. 35 (10 A) in the under-hood relay box.
- Check for an open circuit in the WHT/YEL wire between the EFI ECU fuse No. 35 (10 A) and A/T control unit B12 terminal.

After making repair, disconnect the EFI ECU fuse No. 35 (10 A) in the under-hood relay box for more than ten seconds to reset LED display memory.



# Technical Service Information

## Electrical System

Number of LED display blinks	S <sub>3</sub> indicator light	Symptom	Probable Cause
1	Blinks	<ul style="list-style-type: none"> <li>• Lock-up clutch does not engage.</li> <li>• Lock-up-clutch does not disengage.</li> <li>• Frequent engine stalling.</li> </ul>	<ul style="list-style-type: none"> <li>• Disconnected lock-up control solenoid valve A connector</li> <li>• Open or short in lock-up control solenoid valve A wire</li> <li>• Faulty lock-up control solenoid valve A</li> </ul>
2	Blinks	<ul style="list-style-type: none"> <li>• Lock-up clutch does not engage.</li> </ul>	<ul style="list-style-type: none"> <li>• Disconnected lock-up control solenoid valve B connector</li> <li>• Open or short in lock-up control solenoid valve B wire</li> <li>• Faulty lock-up control solenoid valve B</li> </ul>
3	Blinks or OFF	<ul style="list-style-type: none"> <li>• Lock-up clutch does not engage.</li> </ul>	<ul style="list-style-type: none"> <li>• Disconnected throttle angle sensor connector</li> <li>• Open short in throttle angle sensor wire</li> <li>• Faulty throttle angle sensor</li> </ul>
4	Blinks	<ul style="list-style-type: none"> <li>• Lock-up clutch does not engage.</li> </ul>	<ul style="list-style-type: none"> <li>• Disconnected speed pulser connector</li> <li>• Open or short in speed pulser wire</li> <li>• Faulty speed pulser</li> </ul>
5	Blinks	<ul style="list-style-type: none"> <li>• Fails to shift other than 2nd ↔ 4th gear.</li> <li>• Lock-up clutch does not engage.</li> </ul>	<ul style="list-style-type: none"> <li>• Short in shift position console switch wire</li> <li>• Faulty shift position console switch</li> </ul>
6	OFF	<ul style="list-style-type: none"> <li>• Fails to shift other than 2nd ↔ 4th gear.</li> <li>• Lock-up clutch does not engage.</li> <li>• Lock-up clutch engages and disengages alternately.</li> </ul>	<ul style="list-style-type: none"> <li>• Disconnected shift position console switch connector</li> <li>• Open in shift position console switch wire</li> <li>• Faulty shift position console switch.</li> </ul>
7	Blinks	<ul style="list-style-type: none"> <li>• Fails to shift other than 1st ↔ 4th, 2nd ↔ 4th, or 2nd ↔ 3rd gears.</li> <li>• Fails to shift (stuck in 4th gear).</li> </ul>	<ul style="list-style-type: none"> <li>• Disconnected shift control solenoid valve A connector</li> <li>• Open or short in shift control solenoid valve A wire</li> <li>• Faulty shift control solenoid valve A</li> </ul>
8	Blinks	<ul style="list-style-type: none"> <li>• Fails to shift (stuck in 1st gear or 4th gear).</li> </ul>	<ul style="list-style-type: none"> <li>• Disconnected shift control solenoid valve B connector</li> <li>• Open or short in shift control solenoid valve B wire</li> <li>• Faulty shift control solenoid valve B</li> </ul>
9	Blinks	<ul style="list-style-type: none"> <li>• Lock-up clutch does not engage.</li> </ul>	<ul style="list-style-type: none"> <li>• Disconnected A/T speed pulser</li> <li>• Open or short in A/T speed pulser wire</li> <li>• Faulty A/T speed pulser</li> </ul>
10	Blinks	<ul style="list-style-type: none"> <li>• Lock-up clutch does not engage.</li> </ul>	<ul style="list-style-type: none"> <li>• Disconnected coolant temperature sensor connector</li> <li>• Open or short in coolant temperature sensor wire</li> <li>• Faulty coolant temperature sensor</li> </ul>
11	OFF	<ul style="list-style-type: none"> <li>• Lock-up clutch does not engage.</li> </ul>	<ul style="list-style-type: none"> <li>• Disconnected ignition coil connector</li> <li>• Open or short in ignition coil wire</li> <li>• Faulty ignition coil</li> </ul>

**NOTE:**

- If a customer describes the symptoms for codes 3, 6 or 11, yet the LED is not blinking, it will be necessary to recreate the symptom by test driving, and then checking the LED with the ignition STILL ON.
- If the LED display blinks 12 or more times, the control unit is faulty.



# Technical Service Information

If the self-diagnosis LED indicator does not blink, perform an inspection according to the table listed below.

Symptom	INSPECTION		Probable Cause
	Carbureted engine	Fuel-injected engine	
<ul style="list-style-type: none"> <li>• S<sub>3</sub> indicator light does not come on with the ignition switch ON (S<sub>3</sub> indicator light should come on for about 2 sec.).</li> <li>• Fails to shift (stuck in 4th gear).</li> </ul>	①	①	<ul style="list-style-type: none"> <li>• Loosely or poorly connected power line to control unit or disconnected control unit ground wire</li> <li>• Open or short in S<sub>3</sub> indicator light wire</li> <li>• Blown S<sub>3</sub> indicator light bulb</li> </ul>
<ul style="list-style-type: none"> <li>• S<sub>4</sub> won't engage.</li> </ul>	②	②	<ul style="list-style-type: none"> <li>• Open or short in S<sub>4</sub> switch wire</li> <li>• Faulty S<sub>4</sub> switch</li> </ul>
<ul style="list-style-type: none"> <li>• At first, you step on the brake pedal with shift lever in N range, then fails to shift from 2nd to 1st gear when releasing brake pedal with shift lever shifted in S or D range from N range.</li> </ul>	③	③	<ul style="list-style-type: none"> <li>• Open or short in brake light switch wire</li> </ul>
<ul style="list-style-type: none"> <li>• Lock-up clutch turns ON and turns OFF alternately.</li> </ul>	④		<ul style="list-style-type: none"> <li>• Faulty A/C idle up solenoid valve driving signal.</li> </ul>
<ul style="list-style-type: none"> <li>• Lock-up clutch does not engage.</li> </ul>	④		

## Test/Adjustment

**NOTE:** Adjustment for the throttle angle sensor of the fuel injected engine is not required.

1. Connect the inspection adaptor between the throttle angle sensor and the engine wire harness.

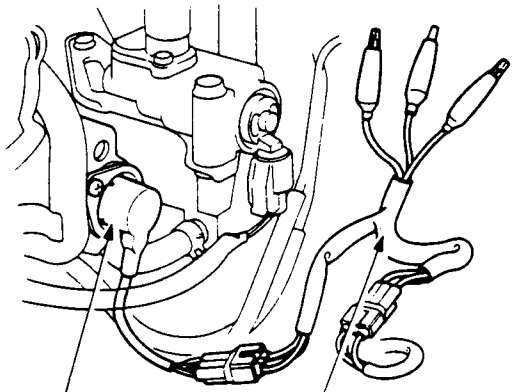

THROTTLE ANGLE SENSOR

INSPECTION ADAPTOR  
07GMJ-ML80100

2. Start the engine and warm it up to normal operating temperature.
3. Stop the engine and turn the ignition switch ON.
4. Measure the voltage between the red clip (+) and green clip (-) of the adaptor.
5. Connect the vacuum pump/gauge to the dashpot diaphragm, and apply vacuum.

NO. 6 VACUUM HOSE

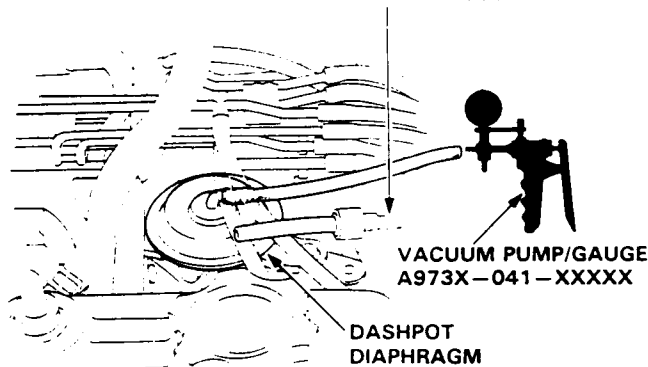

VACUUM PUMP/GAUGE  
A973X-041-XXXX

DASHPOT  
DIAPHRAGM

6. When the throttle valve opening is at idle angle, measure the voltage between the white clip (+) and the green clip (-) of the adaptor.

**STANDARD:** 0.48–0.52 V  $\pm 10\%$  (when the voltage between the red clip and green clip of the adaptor is 5.0 V  $\pm 10\%$ .)

- Reinstall the throttle angle sensor adjusting its position if the voltage is out of specification.

7. When the throttle valve is fully opened, measure the voltage between the white clip (+) and the green clip (-) of the adaptor.

**STANDARD:** 3.80–4.66 V (when the voltage between the red clip and green clip of the adaptor is 5.0 V.)

- Reinstall the throttle angle sensor adjusting its position if the voltage is out of specification, and repeat the test from step 6.



## Test

1. Apply the parking brake, block the rear wheels and jack up the front of the car.
2. Disconnect the A/T speed pulser 2P connector.
3. Rotate the front wheels and be sure that continuity and no continuity appear alternately between the two terminals.

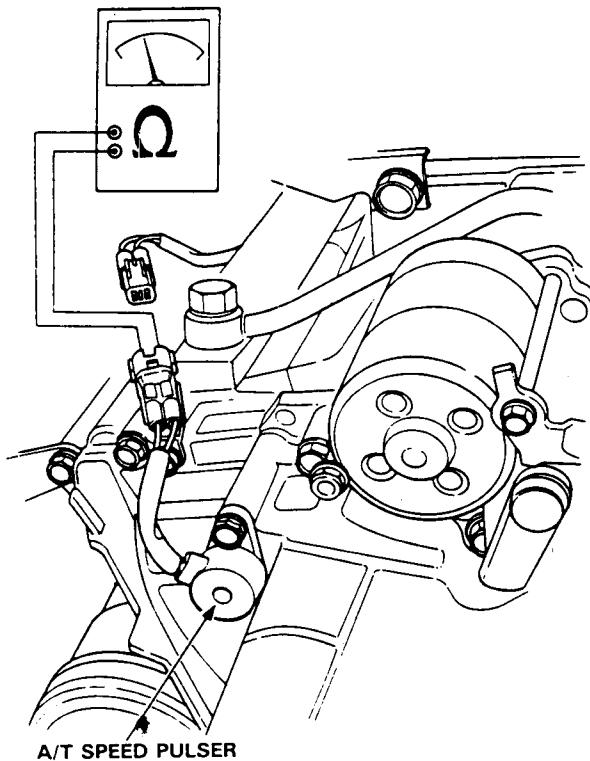

## Removal/Inspection

1. Remove the 6 mm bolt from the transmission housing and remove the A/T speed pulser assembly.

O-RING  
Replace.

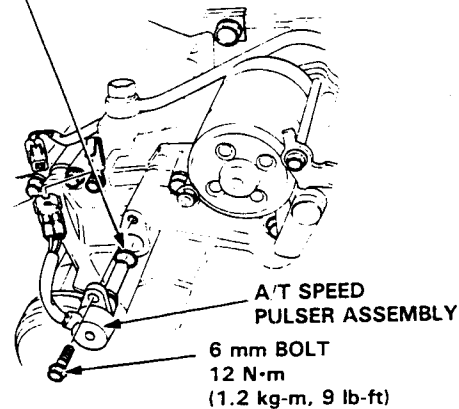

2. Bring a magnet close to the A/T speed pulser assembly and check for continuity.

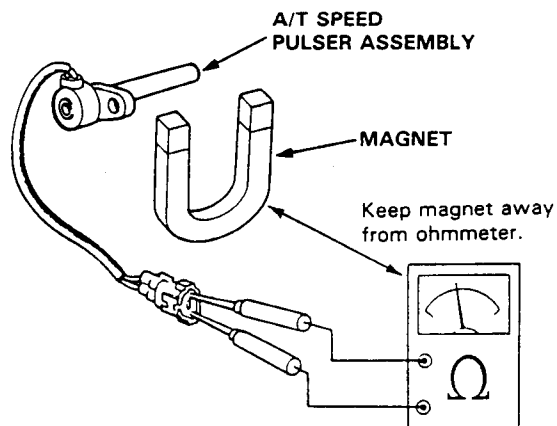

A/T speed pulser assembly is in good condition if there is:

- Continuity with a magnet close to the pulser assembly.
- No continuity with a magnet away from the pulser assembly.

If the A/T speed pulser is normal, go to Rotor Disassembly/Inspection

3. Replace the O-ring with a new one before reassembling the A/T speed pulser.

**CAUTION:** Carefully inspect the A/T speed pulser before installing. Do not install it that shows signs of being dropped or improperly handled.

# Lock-up Control Solenoid Valve A/B

## Test

NOTE: Lock-up control solenoid valves A and B must be removed/replaced as an assembly.

1. Disconnect the connector from the lock-up control solenoid valve A/B.

NOTE: Do not remove the lock-up control solenoid valve A/B stay.

2. Measure the resistance between the No.1 terminal (SOL. V A) of the lock-up control solenoid valve connector and body ground and between the No. 2 terminal (SOL. V B) and body ground.

STANDARD: 14–30  $\Omega$

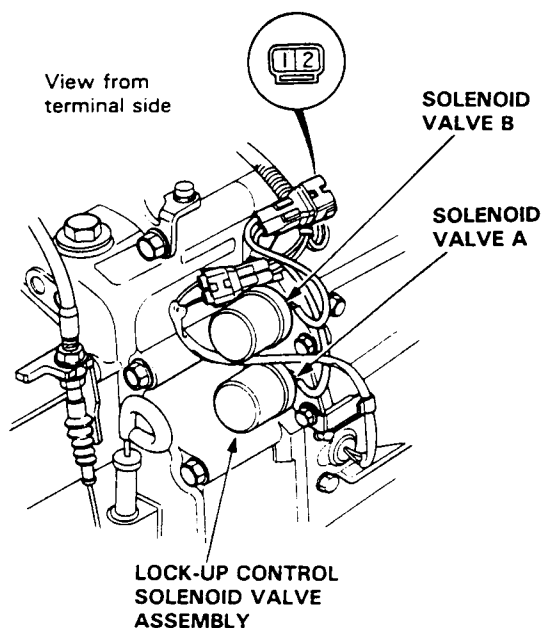

3. Replace the lock-up control solenoid valve assembly if the resistance is out of specification.
4. Connect the No.1 terminal of the lock-up control solenoid valve connector to the battery positive terminal and body ground. Connect the No.2 terminal to the battery positive terminal and body ground. A clicking sound should be heard each time the connection is made.
5. If not, check for continuity between the A/T control unit B3 or B8 harness and body ground.
6. Replace the lock-up control solenoid valve assembly if there is continuity between the A/T control unit B3 or B8 harness and body ground.

## Replacement

1. Remove the four mounting bolts and lock-up control solenoid valve assembly.

NOTE: Be sure to remove or replace the lock-up control solenoid valves A and B as an assembly.

2. Check the lock-up control solenoid valve oil passages for dust or dirt and replace as an assembly, if necessary.

Clean the mounting surface and oil passages.

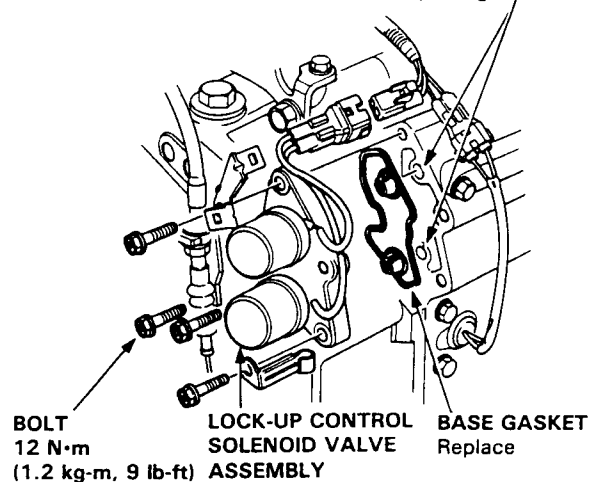

3. Clean the mounting surface and oil passages of the lock-up control solenoid valve assembly and install a new base gasket.
4. Check the connector for rust, dirt or oil and reconnect it securely.

## A/B

### Test

NOTE: Shift control solenoid valves A and B must be removed/replaced as an assembly.

1. Disconnect the connector from the shift control solenoid valve A/B.

NOTE: Do not remove the shift control solenoid valve A/B stay.

2. Measure the resistance between the No.1 terminal (SOL. V A) of the solenoid valve connector and body ground and between the No.2 terminal (SOL. V B) and body ground.

STANDARD: 12–24  $\Omega$

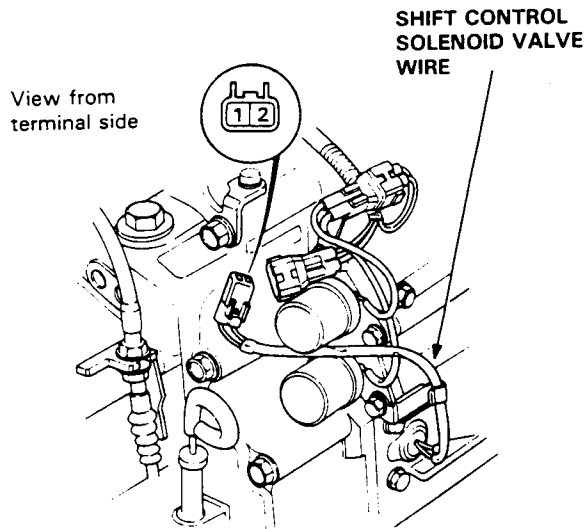

3. Replace the shift control solenoid valve assembly if the resistance is out of specification.
4. Connect the No.1 terminal of the solenoid valve connector to the battery positive terminal and the No.2 terminal to the battery positive terminal. A clicking sound should be heard each time the connection is made.
5. If not check for continuity between the harness and body ground.
6. Replace the shift control solenoid valve assembly if there is continuity between the harness and body ground.

## S4 Switch

### Test

1. Remove the center console.
2. Disconnect the switch connector.
3. Check for continuity between A and B terminals. There should be continuity when the switch is pressed.

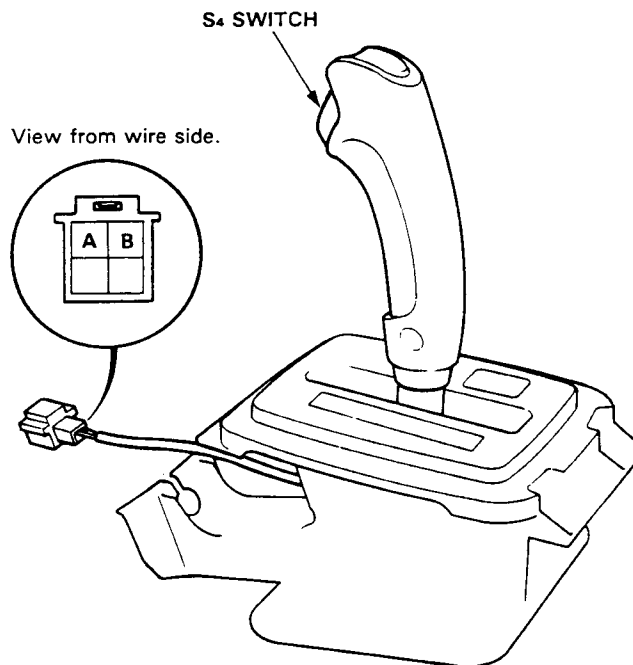



# Technical Service Information

## Hydraulic System

PROBLEM	REFER TO
Engine runs, but car does not move in any gear	1,3,4,5,18,23,24,25,27
Car moves in 2, but not in S or D.	6,10,12,18,40
Car moves in S or D, but not in 2.	7,13,18,40
Car moves in S, D, or 2, but not in R.	9,11,15,18,26,28,40,55
Poor acceleration	
Engine races when starting off in S:	
– Stall rpm high in S, D and 2	1,3,18,24,25,40,46
– Stall rpm high in S and D	10,12,18
– Stall rpm high in 2	13,18
– Stall rpm normal	2
– Stall rpm low	16,56
Excessive idle vibration	3,23,56
Shift-up speed is too fast, or slow.	55
Jumps from 1st to 3rd in S.	55
Jumps from 1st to 4th in D.	55
Shift-up point too early/late:	
– 1st to 2nd, 2nd to 3rd, 3rd to 4th	55
– 1st to 2nd	55
– 2nd to 3rd	55
– 3rd to 4th	55
Harsh upshift from 1st to 2nd	13,31,22,28,34,36,39,40,41,51,55
Harsh upshift from 2nd to 3rd	14,31,22,29,34,37,39,40,41,42,52,55
Harsh upshift from 3rd to 4th	15,31,22,30,34,38,39,40,41,43,51,55
Harsh downshift from 2nd to 1st	13,31,22,28,34,36,39,40,41,51,55
Harsh downshift from 3rd to 2nd	14,31,22,29,34,37,39,40,41,44,52,55
Harsh downshift from 4th to 3rd	15,31,22,30,32,38,39,40,41,45,51,55
Engine races when shifting from 2nd to 3rd	14,17,22,29,34,37,39,40,41,42,52,55
Engine races when shifting from 3rd to 4th (Shift point OK)	15,17,22,30,34,38,39,40,41,43,51,55

	PROBABLE CAUSE
1	ATF level too low
2	ATF level too high
3	Oil pump seized, gear damaged, foreign material suck in gear
4	Mainshaft damaged
5	Final gear and countershaft worn/damaged
6	1st gears worn/damaged
7	2nd gears worn/damaged
8	3rd gears worn/damaged
9	4th gears worn/damaged
10	Countershaft one-way clutch seized/damaged
11	Reverse gears worn/damaged
12	1st clutch faulty a. Clutch piston stuck b. Foreign material stuck in clutch check valve c. Clutch O-ring worn/damaged d. Clutch disc worn e. Clutch feed pipe/O-ring worn/damaged
13	2nd clutch faulty a. Clutch piston stuck b. Foreign material stuck in clutch check valve c. Clutch O-ring worn/damaged d. Clutch disc worn e. Clutch seal ring seized/damaged
14	3rd clutch faulty a. Clutch piston stuck b. Foreign material stuck in clutch check valve c. Clutch O-ring worn/damaged d. Clutch disc worn e. Clutch feed pipe/O-ring worn/damaged
15	4th clutch faulty a. Clutch piston stuck b. Foreign material stuck in clutch check valve c. Clutch O-ring worn/damaged d. Clutch disc worn e. Clutch feed pipe/O-ring worn/damaged
16	Torque converter one-way clutch seized
17	Transmission throttle control cable misadjusted
18	Control cable misadjusted, cut or damaged
19	Mainshaft/countershaft ball bearing damaged
20	Needle bearing seized
21	Washers/collars seized
22	Clutch clearance incorrect
23	Drive plate faulty or transmission assy improperly installed
24	Regulator valve stuck or spring weak/damaged
25	Oil filter clogged



# Technical Service Information

PROBLEM	REFER TO
Excessive shock when shifting from 2nd to 3rd	14,17,22,29,34,37,39,40,41,42,52,55
Excessive shock when shifting from 3rd to 4th (Shift point OK)	15,17,22,30,34,38,39,40,41,43,51,55
Car creeps forward in N. (Shift cable adjusted properly.)	2,12,13,14,15,20,21,22
Excessive time lag from N to S/D (Shift cable adjusted properly.)	12,40,41
Excessive time lag from N to R (Shift cable adjusted properly.)	15,26,28
- Abnormal noise in all gears, neutral and park	3,4,19
- Vibration in all gears	23
- Harsh to shift	18,27
- Car has only 4th gear	55
- Transmission has no park	18,27
- Stall rpm is high, but clutch pressure OK in all positions	46
Harsh shift to lock-up clutch	47,50,53,55
Vibration in lock-up mode	48,49,54,55
Lock-up clutch does not engage.	46,47,48,49,50,53,54,55

	PROBABLE CAUSE
26	Servo shaft stuck
27	Manual valve faulty or roller out of place
28	1-2 shift valve faulty
29	2-3 shift valve faulty
30	3-4 shift valve faulty
31	Modulator valve faulty
32	Throttle valve A faulty
34	Throttle valve B faulty
35	1st accumulator faulty
36	2nd accumulator faulty
37	3rd accumulator faulty
38	4th accumulator faulty
39	Clutch pressure control valve faulty
40	Foreign material stuck in separator orifice
41	Foreign material stuck in check ball
42	2nd orifice control faulty
43	3rd orifice control faulty
44	4-2 kickdown valve faulty
45	4-3 kickdown valve faulty
46	Torque converter check valve faulty
47	Lock-up shift valve faulty
48	Lock-up timing valve B faulty
49	Lock-up control valve faulty
50	Lock-up piston in torque converter faulty
51	Shift control solenoid valve A faulty
52	Shift control solenoid valve B faulty
53	Lock-up control solenoid valve A faulty
54	Lock-up control solenoid valve B faulty
55	Electrical system faulty
56	Engine lacks power



# Technical Service Information

NOTE: After transmission is installed.

- Make sure the floor mat does not interfere with accelerator pedal travel. Fully depress accelerator pedal and check to make sure the throttle lever is fully opened.
- Release the accelerator pedal and check both inner control cables to be sure they have slight play.

Warm up the engine to operating temperature.

## D and S Range

1. Apply parking brake and block the wheels. Start the engine, then move the selector to **D** while depressing the brake pedal. Depress the accelerator pedal, and release it suddenly. Engine should not stall.
2. Check that shift points occur at approximate speeds shown. Also check for abnormal noise and clutch slippage.
3. Apply parking brake and block the wheels. Start the engine, then move the selector **S** while depressing the brake pedal. Depress the accelerator pedal, and release it suddenly. Engine should not stall.

(Carburetor)

### Upshift

		1st-2nd	2nd-3rd	3rd-4th	LC.ON
1/12 throttle Coasting down-hill from a stop	km/h	17.7-20.9	32.2-38.6	41.8-51.5	20.9-27.4
	mph	11-13	20-24	26-32	13-17
7/16 throttle Acceleration from a stop	km/h	27.4-33.8	53.1-62.8	86.9-96.5	95.0-101.4
	mph	17-21	33-39	54-60	59-63
Full-throttle Acceleration from a stop	km/h	56.3-64.4	101.4-111.0	145-154.5	130.3-136.8
	mph	35-40	63-69	90-96	81-85

		1st-2nd	2nd-3rd	3rd-4th	LC.ON
1/12 throttle Coasting down-hill from a stop	km/h	17.7-20.9	33.8-40.2	57.9-67.6	35.4-41.8
	mph	11-13	21-25	36-42	22-26
7/16 throttle Acceleration from a stop	km/h	27.4-33.8	62.8-72.4	106.2-115.8	114.2-120.7
	mph	17-21	39-45	66-72	71-75
Full throttle Acceleration from a stop	km/h	56.3-64.4	101.4-111	144.8-154.5	130.3-136.8
	mph	35-40	63-69	90-96	81-85

### Downshift

		LC.OFF	4th-3rd	3rd-2nd	2nd-1st
1/12 throttle Coasting or braking to a stop	km/h	17.7-24.1	—	29.0-35.4	6.4-11.3
	mph	11-15	—	18-22	4-7
7/16 throttle When car is slowed by increased grade, wind, etc.	km/h	72.4-78.8	—	—	—
	mph	45-49	—	—	—
Full-throttle When car is slowed by increased grade, wind, etc.	km/h	127.1-138.4	125.5-138.4	83.7-94.9	37.0-46.7
	mph	79-86	78-86	52-59	23-29

		LC.OFF	4th-3rd	3rd-2nd	2nd-1st
1/12 throttle Coasting or braking to a stop	km/h	32.2-38.6	—	29.0-35.4	6.4-11.3
	mph	20-24	—	18-22	4-7
7/16 throttle When car is slowed by increased grade, wind, etc.	km/h	83.7-90.1	—	—	—
	mph	52-56	—	—	—
Full-throttle When car is slowed by increased grade, wind, etc.	km/h	127.1-138.4	125.5-138.4	83.7-94.9	37.0-46.7
	mph	79-83	78-86	52-59	23-29



# Technical Service Information

(PGM-FI)

• Upshift

**D**

		1st-2nd	2nd-3rd	3rd-4th	LC.ON
1/12 throttle Coasting down-hill from a stop	km/h	20.9-24.1	35.4-41.8	48.3-57.9	20.9-27.4
	mph	13-15	22-26	30-36	13-17
7/16 throttle Acceleration from a stop	km/h	27.4-33.8	53.1-62.8	86.9-96.5	77.2-83.7
	mph	17-21	33-39	54-60	48-52
Full-throttle Acceleration from a stop	km/h	53.1-61.1	101.4-111.0	144.8-154.5	127.1-133.5
	mph	33-38	63-69	90-96	79-83

**S** (with S4 switch in operation)

		1st-2nd	2nd-3rd	3rd-4th	LC.ON
1/12 throttle Coasting down-hill from a stop	km/h	17.7-20.9	37.0-43.4	57.9-67.6	35.4-41.8
	mph	11-13	23-27	36-42	22-26
7/16 throttle Acceleration from a stop	km/h	27.4-33.8	62.8-72.4	99.8-109.4	112.6-119.1
	mph	17-21	39-45	62-68	70-74
Full-throttle Acceleration from a stop	km/h	53.1-61.1	101.4-111.0	144.8-154.5	127.1-133.5
	mph	33-38	63-69	90-96	79-83

• Downshift

**D**

		LC.OFF	4th-3rd	3rd-2nd	2nd-1st
1/12 throttle Coasting or braking to a stop	km/h	17.7-24.1	—	29.0-35.4	9.7-14.5
	mph	11-15	—	18-22	6-9
7/16 throttle When car is slowed by increased grade, wind, etc.	km/h	77.2-83.7	—	—	—
	mph	48-52	—	—	—
Full-throttle When car is slowed by increased grade, wind, etc.	km/h	123.9-130.3	120.7-133.5	91.7-103.0	38.6-48.3
	mph	77-81	75-83	57-64	24-30

**S** (with S4 switch in operation)

		LC.OFF	4th-3rd	3rd-2nd	2nd-1st
1/12 throttle Coasting or braking to a stop	km/h	32.2-38.6	—	29.0-35.4	9.7-14.5
	mph	20-24	—	18-22	6-9
7/16 throttle When car is slowed by increased grade, wind, etc.	km/h	83.7-90.1	—	—	—
	mph	52-56	—	—	—
Full-throttle When car is slowed by increased grade, wind, etc.	km/h	123.9-130.3	120.7-133.5	91.7-103.0	38.6-48.3
	mph	77-81	75-83	57-64	24-30

CAUTION: Do not shift from **D** or **S** to **2** at speeds over 60 mph; you may damage the transmission.

**2** (2nd Gear)

1. Accelerate from a stop at full throttle. Check that there is no abnormal noise or clutch slippage.
2. Upshifts and downshifts should not occur with the selector in this range.

**R** (Reverse)

Accelerate from a stop at full throttle, and check for abnormal noise and clutch slippage.

**P** (Park)

Park car on a slope (approx. 16°), apply the parking brake, and shift into Park. Release the brake; the car should not move.

## Testing

**CAUTION:** Before testing, be sure transmission is filled to proper level.

**NOTE:**

- Stop engine when attaching hoses for pressure tests.
- Torque hose fitting to 18 N·m (1.8 kg-m, 12 lb-ft).
- Do not reuse aluminum washers.

A/T OIL PRESSURE  
GAUGE SET 07406-00200003 (Includes pressure hoses)  
A/T OIL PRESSURE GAUGE HOSE 07406-0020201

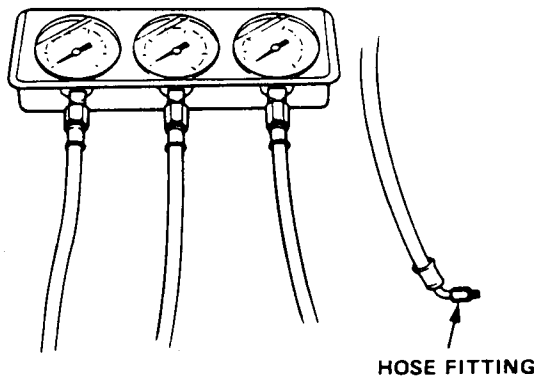

**Line Pressure Measurement**

- Set the parking brake securely.
- Jack up the front of the car and support it with a rigid rack.
- Run the engine at 2,000 rpm.

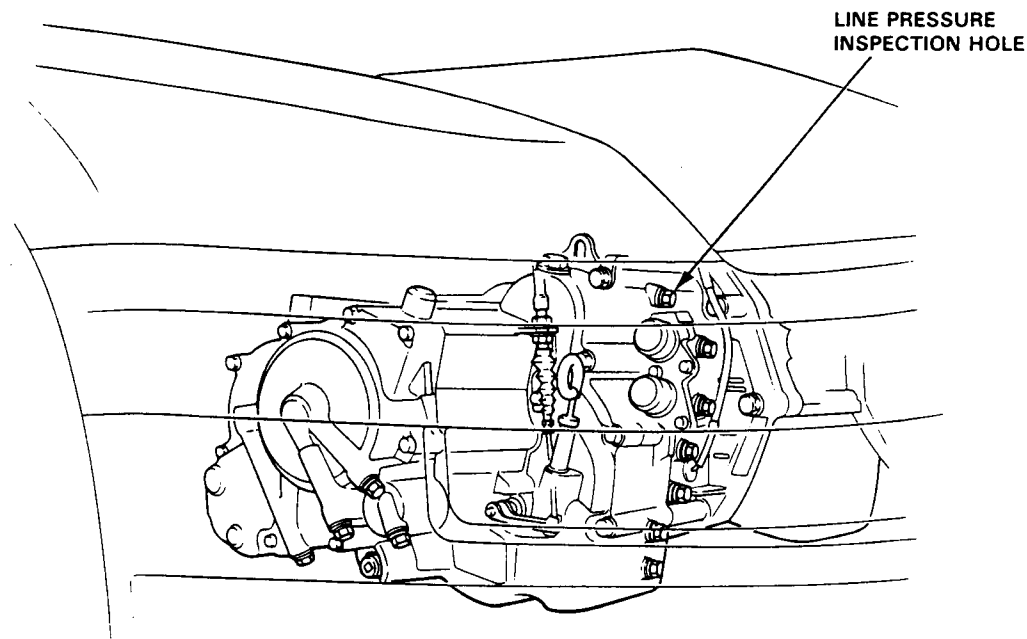

PRESSURE	SELECTOR POSITION	PROBABLE CAUSE	FLUID PRESSURE			
			PGM-FI		Carburetor	
			Standard	Service limit	Standard	Service limit
Line	<b>N</b> or <b>P</b>	Torque converter, oil pump pressure regulator, torque converter check valve, oil pump	834-883 kPa (8.5-9.0 kg/cm <sup>2</sup> , 121-128 psi)	785 kPa (8.0 kg/cm <sup>2</sup> , 114 psi)	785-834 kPa (8.0-8.5 kg/cm <sup>2</sup> , 114-121 psi)	736 kPa (7.5 kg/cm <sup>2</sup> , 107 psi)



## Clutch Pressure Measurement

- Set the parking brake securely and block the wheels.
- Jack up the front of the car and support it with a rigid rack.
- Run the engine at 2,000 rpm.

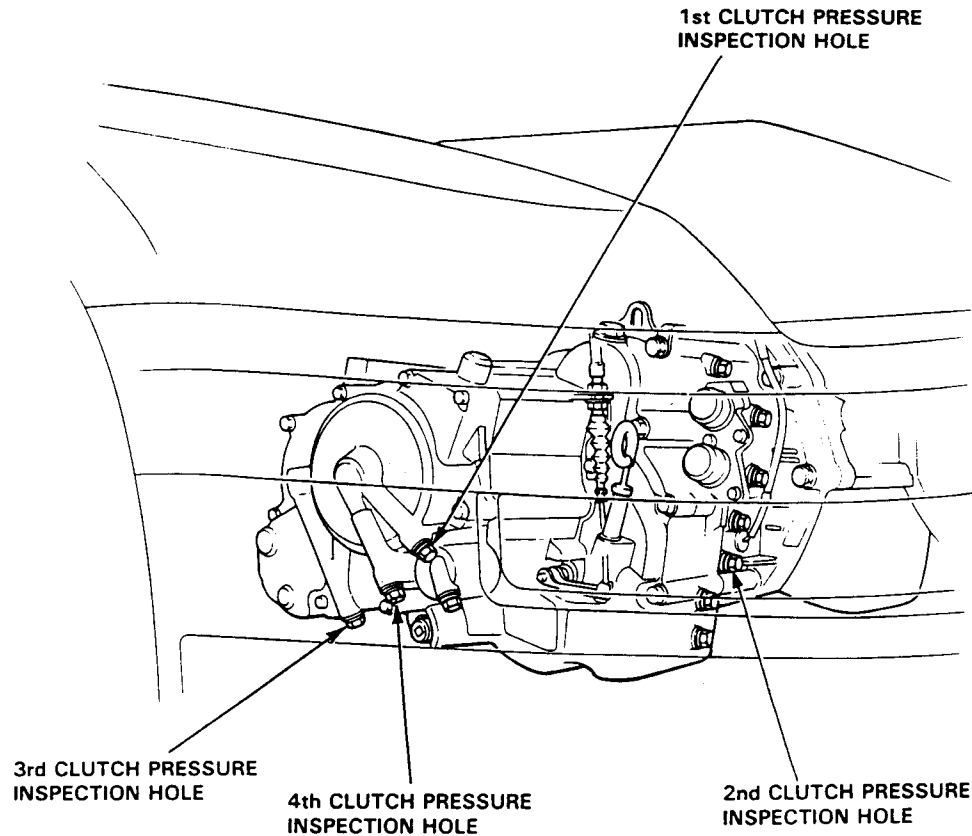

PRESSURE	SELECTOR POSITION	SYMPTOM	PROBABLE CAUSE	FLUID PRESSURE kPa (kg/cm <sup>2</sup> , psi)			
				PGM-FI		CARBURETOR	
				Standard	Service limit	Standard	Service limit
1st Clutch	[S] or [D]	No or low 1st pressure	1st Clutch	834–883 (8.5–9.0, 121–128)	785 (8.0, 114)	785–834 (8.0–8.5, 114–121)	736 (7.5, 107)
2nd Clutch	[2]	No or low 2nd pressure	2nd Clutch				
2nd Clutch	[S] or [D]	No or low 2nd pressure	2nd Clutch	569 – 883 (5.8, 9.0, 82)   128	520 (5.3, 75) (Closed)   785 (8.0, 114) (3/8 below)	569 – 834 (5.8, 8.5, 82)   121	520 (5.3, 75) (Closed)   785 (8.0, 114) (below)
3rd Clutch	[S] or [D]	No or low 3rd pressure	3rd Clutch				
4th Clutch	[S] (with S4 switch in operation or [D])	No or low 4th pressure	4th Clutch	Throttle control lever fully closed   Throttle control lever opened 3/8 or more	Enclosed in parenthesis are throttle control lever opening angles	Throttle control lever fully closed   Throttle control lever opened 3/8 or more	Enclosed in parenthesis are throttle control lever opening angles
	[R]		Servo valve or 4th Clutch	834–883 (8.5–9.0, 121–128)	785 (8.0, 114)	785–834 (8.0–8.5, 114–121)	736 (7.5, 107)

(cont'd)



## Pressure

### Testing (cont'd)

#### Throttle B Pressure Measurement

- Set the parking brake securely and block the wheels.
- Run the engine at 1,000 rpm.
- Disconnect the throttle control cable from the throttle lever and set the control lever in full throttle position.

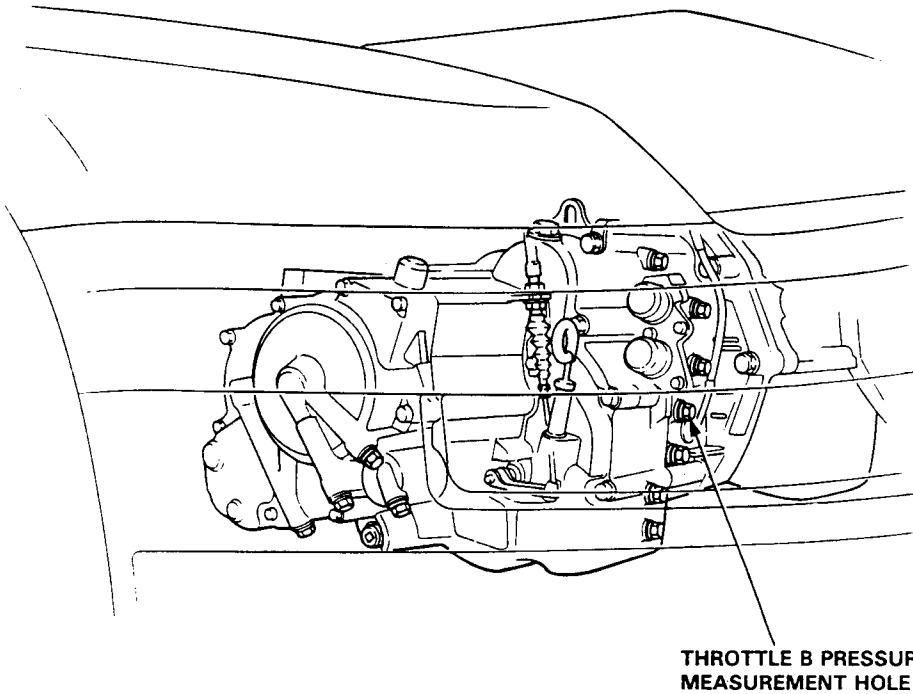

THROTTLE B PRESSURE MEASUREMENT HOLE

PRESSURE	SELECTOR POSITION	SYMPTOM	PROBABLE CAUSE	FLUID PRESSURE kPa (kg/cm <sup>2</sup> , psi)			
				PGM-FI		CARBURETOR	
				Standard	Service limit	Standard	Service limit
Throttle B	S or D	No (or low) Throttle B pressure	Throttle valve B	0 (close) 834–883 (8.5–9.0, 121–128) (fully opened) Enclosed in parentheses are throttle control lever opening angles.	— 785 (8.0, 114) (fully opened) Enclosed in parentheses are throttle control lever opening angles.	0 (close) 785–834 (8.0–8.5, 114–121) (fully opened) Enclosed in parentheses are throttle control lever opening angles.	— 686 (7.0, 100) (fully opened) Enclosed in parentheses are throttle control lever opening angles.

## Test

### CAUTION:

- To prevent transmission damage, do not test stall speed for more than 10 seconds at a time.
- Do not shift the lever while rising the engine speed.
- Be sure to remove the pressure gauge before testing stall speed.

1. Engage parking brake and block the front wheels.
2. Connect safety chains to both front two hooks and attach, with minimum slack, to some strong stationary object.
3. Connect tachometer, and start the engine.
4. After the engine has warmed up to normal operating temperature, shift into **2**.
5. Fully depress the brake pedal and accelerator for 6 to 8 seconds, and note engine speed.
6. Allow 2 minutes for cooling, then repeat same test in **D**, **S**, and **R**.

Stall speed in **D**, **S**, **2** and **R** must be the same, and must also be within limits:

### NOTE:

Stall speed test must be made only for checking the cause of trouble.

### Stall Speed RPM:

(Carburetor)

Standard: 2,600 rpm

Service Limit: 2,450–2,750 rpm

(PGM-FI)

Standard: 2,650 rpm

Service Limit: 2,500–2,800 rpm

TROUBLE	PROBABLE CAUSE
Stall rpm high in <b>D</b> , <b>S</b> , <b>2</b> & <b>R</b>	<ul style="list-style-type: none"> <li>• Low fluid level or oil pump output.</li> <li>• Clogged oil strainer.</li> <li>• Pressure regulator valve stuck closed.</li> <li>• Slipping clutch.</li> </ul>
Stall rpm high in <b>R</b>	<ul style="list-style-type: none"> <li>• Slippage of 4th clutch</li> </ul>
Stall rpm high in <b>2</b>	<ul style="list-style-type: none"> <li>• Slippage of 2nd clutch</li> </ul>
Stall rpm high in <b>D</b> & <b>S</b>	<ul style="list-style-type: none"> <li>• Slippage of 1st clutch or 1st gear one-way clutch</li> </ul>
Stall rpm low in <b>D</b> , <b>S</b> , <b>2</b> & <b>R</b>	<ul style="list-style-type: none"> <li>• Engine output low</li> <li>• Torque converter one-way clutch slipping</li> </ul>

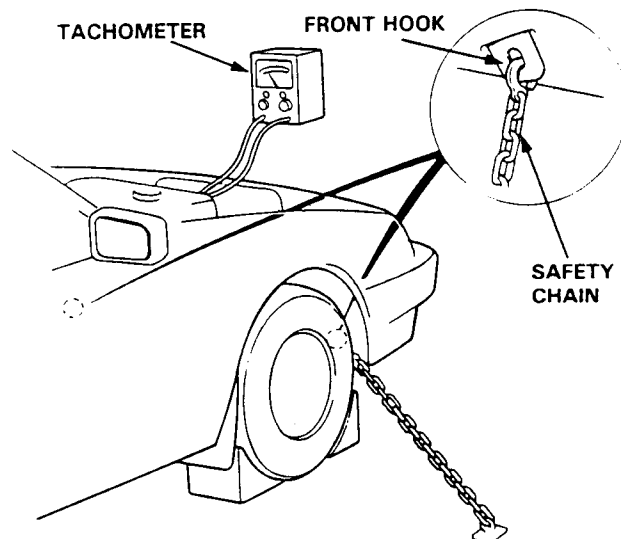

## Checking/Changing

### Checking

After the engine has warmed up to normal operating temperature.

With the car on level ground; pull the transmission dipstick and check the level of fluid immediately after the engine is shut off (within one minute). The fluid level should be between the full and low marks. Push the dipstick all the way in to check the fluid level. If the level is at, or below, the low mark, and DEXRON-II type automatic transmission fluid.

### Changing

1. Bring the transmission up to operating temperature by driving the car. Park the car on level ground, turn the engine off, then remove drain plug.
2. Reinstall the drain plug with a new washer, then refill the transmission to the full mark on the dipstick.

#### Automatic transmission Capacity:

2.8 l (3.0 U.S. qts. 2.5 Imp. qt) at change

6.2 l (6.6 U.S. qts. 5.5 Imp. qt) after overhaul

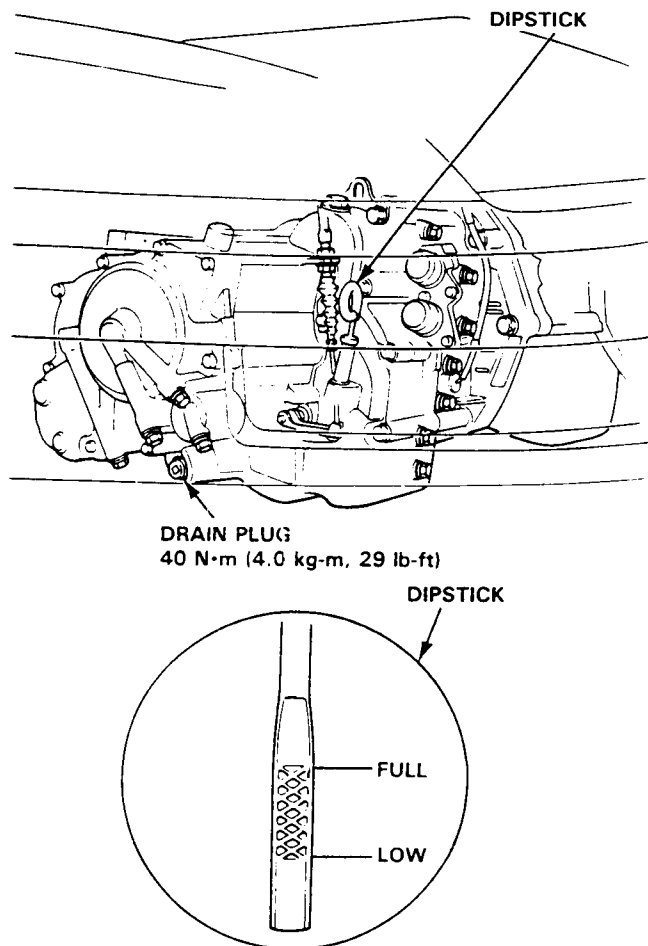

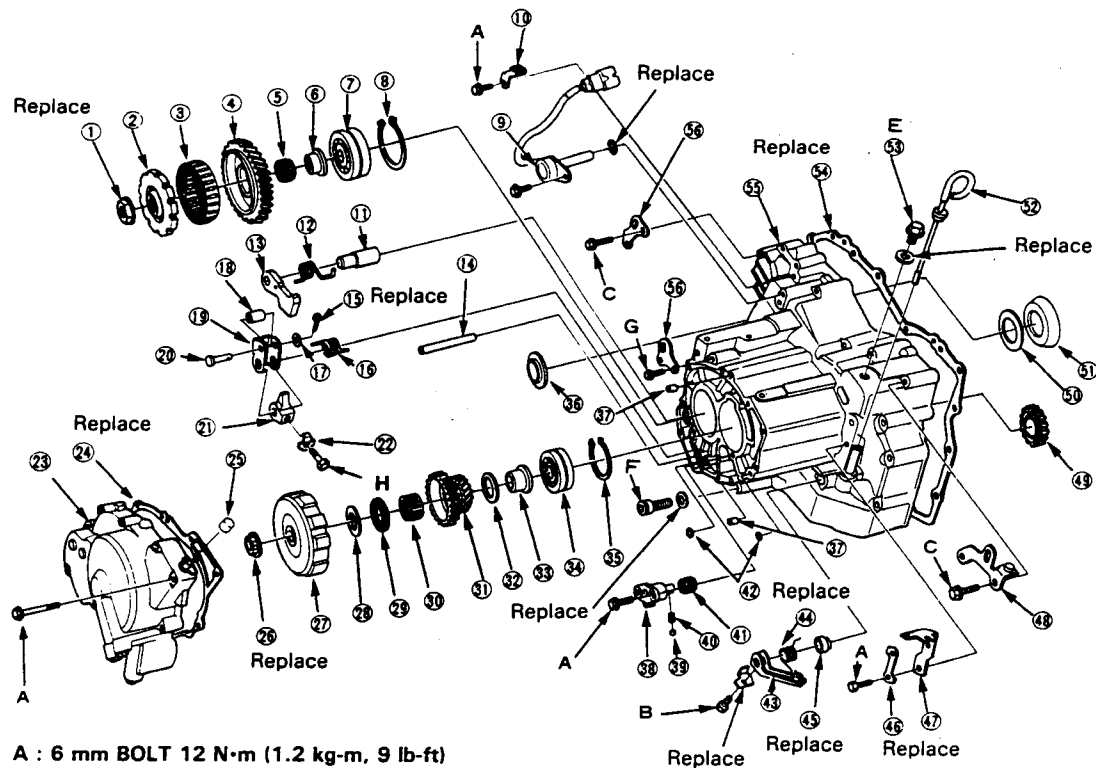

- A : 6 mm BOLT 12 N·m (1.2 kg-m, 9 lb-ft)  
 B : 5 mm BOLT 8 N·m (0.8 kg-m, 6 lb-ft)  
 C : 10 mm BOLT 50 N·m (5.5 kg-m, 40 lb-ft)  
 D : 8 mm SEALING BOLT 18 N·m (1.8 kg-m, 13 lb-ft)  
 E : 20 mm FILLER BOLT 45 N·m (4.5 kg-m, 33 lb-ft)  
 F : 14 mm DRAIN PLUG 40 N·m (4.0 kg-m, 29 lb-ft)  
 G : 8 mm BOLT 22 N·m (2.2 kg-m, 16 lb-ft)  
 H : 6 mm BOLT 14 N·m (1.4 kg-m, 11 lb-ft)

- |   |   |                                       |                                     |
|---|---|---------------------------------------|-------------------------------------|
| ① LOCK NUT 23 mm<br>140 → 0 → 140 N·m<br>(14.0 → 0 → 14.0 kg-m,<br>102 → 0 → 102 lb-ft)<br>Removal, 14-80<br>Installation, 14-129 | ⑭ STOP PIN  | ⑳ THRUST WASHER 26 mm                 | ④④ THROTTLE CONTROL<br>SHAFT SPRING |
| ② PARKING GEAR<br>ONE-WAY CLUTCH<br>Disassembly/Inspection,<br>page 14-89   | ⑮ COTTER PIN 1.6 mm   | ㉑ THRUST NEEDLE<br>BEARING            | ④⑤ OIL SEAL                         |
| ③ 1st GEAR<br>NEEDLE BEARING<br>32 x 38 x 14 mm   | ⑯ PARKING PAWL SPRING<br>WASHER 6 mm  | ㉒ NEEDLE BEARING<br>31 x 36 x 18.5 mm | ④⑥ LOCK PLATE                       |
| ④ 1st GEAR<br>COLLAR  | ⑰ PARKING BRAKE ROLLER  | ㉓ 1st GEAR                            | ④⑦ THROTTLE CABLE STAY              |
| ⑤ 26 x 68 x 18 mm   | ⑱ PARKING SHIFT ARM   | ㉔ THRUST WASHER<br>31 x 42 x 1.5 mm   | ④⑧ TRANSMISSION<br>HANGER           |
| ⑥ 26 x 68 x 18 mm   | ⑲ ROLLER PIN  | ㉕ COLLAR 26 mm                        | ④⑨ REVERSE IDLER GEAR               |
| ⑦ 26 x 68 x 18 mm   | ⑳ PARKING BRAKE<br>STOPPER  | ㉖ BALL BEARING<br>26 x 75 x 19 mm     | ⑤① DIFFERENTIAL THRUST<br>SHIM      |
| ⑧ 26 x 68 x 18 mm   | ㉑ LOCK WASHER   | ㉗ SNAP RING 75 mm                     | ⑤② BEARING OUTER RACE               |
| ⑨ 26 x 68 x 18 mm   | ㉒ END COVER   | ㉘ OIL SEAL                            | ⑤③ DIPSTICK                         |
| ⑩ 26 x 68 x 18 mm   | ㉓ BREATHER CAP<br>LOCK NUT 19 mm<br>95 → 0 → 95 N·m (9.5<br>→ 0 → 9.5 kg-m, 69 → 0<br>→ 69 lb-ft)<br>Removal, page 14-81<br>Installation, page 14-129 | ㉙ Installation, see section<br>15     | ⑤④ FILLER BOLT                      |
| ⑪ 26 x 68 x 18 mm   | ㉔ 1st CLUTCH ASSEMBLY<br>Removal, page 14-81<br>Disassembly, page 14-104<br>Reassembly, page 14-110   | ㉚ DOWEL PIN 8 x 14 mm                 | ⑤⑤ GASKET                           |
| ⑫ 26 x 68 x 18 mm   |   | ㉛ REVERSE IDLER GEAR<br>HOLDER        | ⑤⑥ TRANSMISSION<br>HOUSING          |
| ⑬ 26 x 68 x 18 mm   |   | ㉜ STEEL BALL                          | ⑤⑦ TRANSMISSION<br>HANGER           |
|   |   | ㉝ IDLER SPRING                        |                                     |
|   |   | ㉞ NEEDLE BEARING<br>14 x 18 x 15 mm   |                                     |
|   |   | ㉟ O-RING 7.7 x 2.3 mm                 |                                     |
|   |   | ㊱ THROTTLE CONTROL<br>LEVER           |                                     |

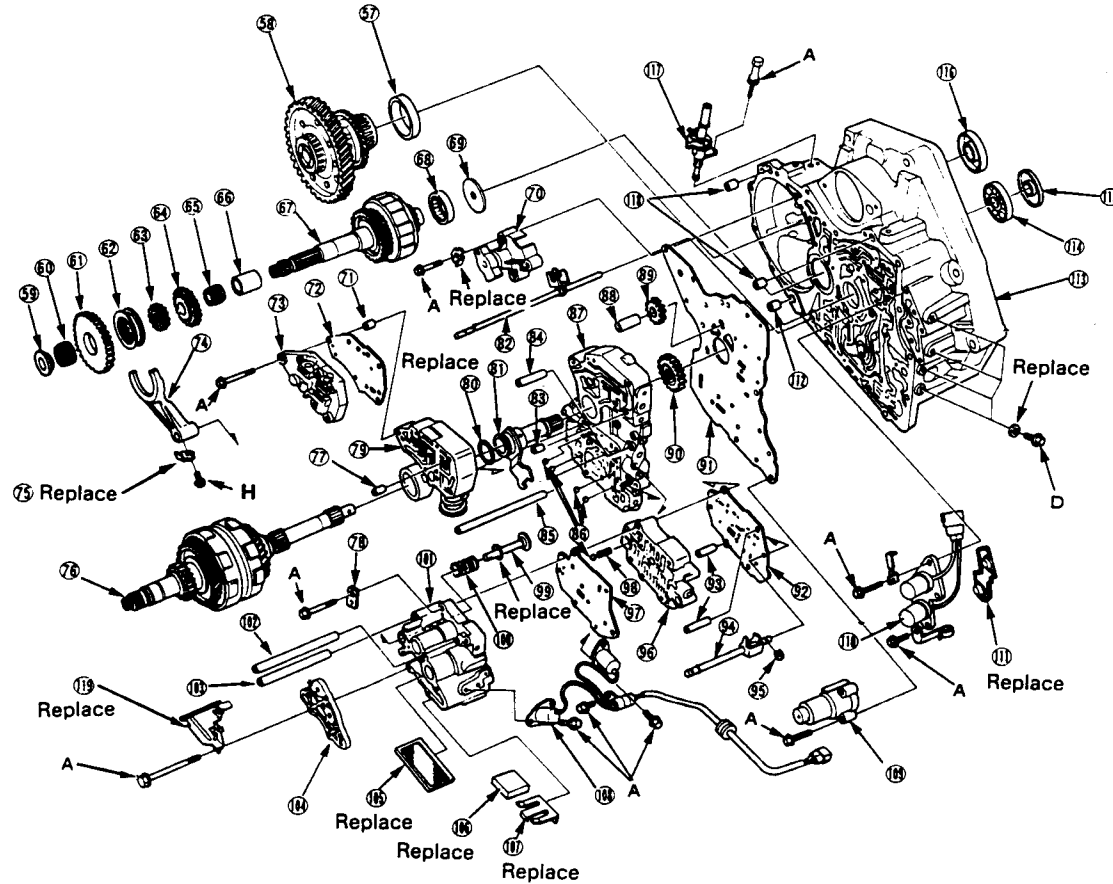

- |   |   |  |  |
|---|---|--|--|
| 57 DIFFERENTIAL BEARING<br>OUTER RACE   | 73 LOCK-UP TIMING VALVE<br>BODY<br>Removal, page 14-87<br>Disassembly/Inspection,<br>page 14-97 | 90 PUMP DRIVE GEAR   | 108 SHIFT CONTROL SOLENOID<br>VALVE ASSEMBLY   |
| 58 DIFFERENTIAL<br>ASSEMBLY   | 74 REVERSE SHIFTFORK  | 91 MAIN VALVE BODY   | 109 2nd ACCUMULATOR<br>BODY  |
| 59 REVERSE GEAR COLLAR  | 75 LOCK WASHER  | 92 SECONDARY<br>SEPARATOR PLATE  | 110 LOCK-UP CONTROL<br>SOLENOID VALVE<br>ASSEMBLY<br>Inspection, page 14-64<br>Replacement, page 14-64 |
| 60 NEEDLE BEARING<br>32 x 38 x 14 mm  | 76 MAINSHAFT<br>Disassembly/Inspection,<br>page 14-103  | 93 DOWEL PIN 8 x 40 mm   | 111 LOCK-UP CONTROL<br>SOLENOID<br>BASE GASKET   |
| 61 REVERSE GEAR   | 77 DOWEL PIN  | 94 THROTTLE VALVE<br>SHAFT   | 112 DOWEL PIN 14 x 25 mm   |
| 62 REVERSE GEAR<br>SELECTOR   | 78 LOCK PLATE   | 95 E-CLIP 7 mm   | 113 TORQUE CONVERTER<br>HOUSING  |
| 63 SELECTOR HUB   | 79 REGULATOR VALVE<br>BODY<br>Removal, page 14-87   | 96 SECONDARY VALVE<br>BODY ASSEMBLY                                    | 114 BALL BEARING<br>40 x 68 x 9 mm   |
| 64 COUNTER SHAFT<br>4th GEAR  | 80 O-Ring 31 x 1.7 mm   | 97 SERVO SEPARATOR<br>PLATE  | 115 OIL SEAL 44 x 68 x 8 mm  |
| 65 NEEDLE BEARING<br>28 x 33 x 20 mm  | 81 STATOR SHAFT ARM   | 98 SPRING  | 116 OIL SEAL 38 x 54 x 8 mm  |
| 66 DISTANCE COLLAR 28 mm  | 82 CONTROL SHAFT  | 99 SHIFTFORK SHAFT   | 117 SPEED SENSOR<br>ASSEMBLY   |
| 67 COUNTER SHAFT<br>Disassembly/Inspection/<br>Reassembly, page 14-100                | 83 DOWEL PIN  | 100 SERVO RETURN SPRING  | 118 DOWEL PIN 14 x 20 mm   |
| 68 ROLLER BEARING<br>38.5 x 67 x 19 mm  | 84 STOP PIN 8 x 80 mm   | 101 SERVO VALVE BODY<br>Removal, page 14-86<br>Disassembly, page 14-98 | 119 BAFFLE PLATE   |
| 69 OIL GUIDE PLATE  | 85 1st CLUTCH PIPE  | 102 4th CLUTCH PIPE  |  |
| 70 SPEED PULSER ROTOR<br>Replace, page 14-84<br>Disassembly/Inspection,<br>page 14-84 | 86 STEEL BALLS  | 103 3rd CLUTCH PIPE  |  |
| 71 DOWEL PIN 8 X 14 mm  | 87 MAIN VALVE BODY<br>Removal, page 14-88<br>Disassembly, page 14-91                            | 104 ACCUMULATOR COVER  |  |
| 72 LOCK-UP TIMING VALVE<br>SEPARATOR PLATE  | 88 PUMP GEAR SHAFT  | 105 FILTER SCREEN  |  |
|   | 89 PUMP DRIVEN GEAR   | 106 TRANSMISSION<br>MAGNET   |  |
|   |   | 107 MAGNET HOLDER<br>SPRING  |  |

# Transmission Housing

## Removal

1. Remove the transmission cooler pipes A and B from the transmission.

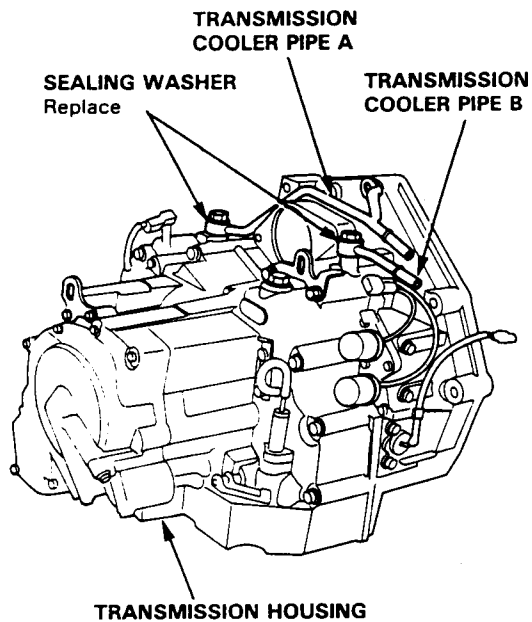

2. Remove the ten bolts from the end cover, then remove the cover.

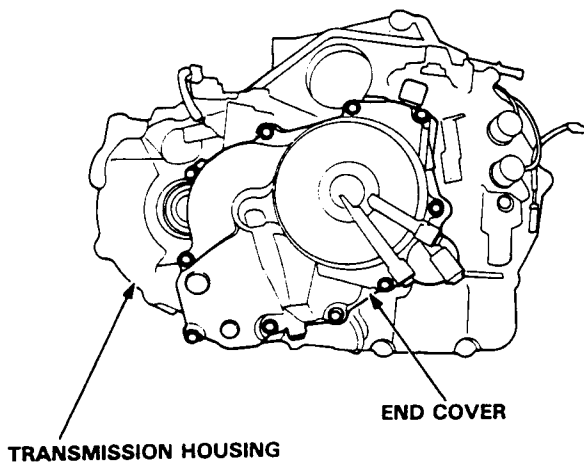

3. Remove the end cover gasket, dowel pins, and O-rings.

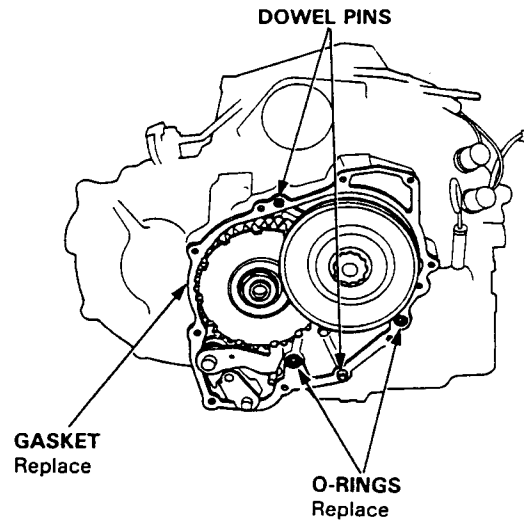

4. Shift the transmission to PARK.  
Lock the mainshaft using the mainshaft holder.

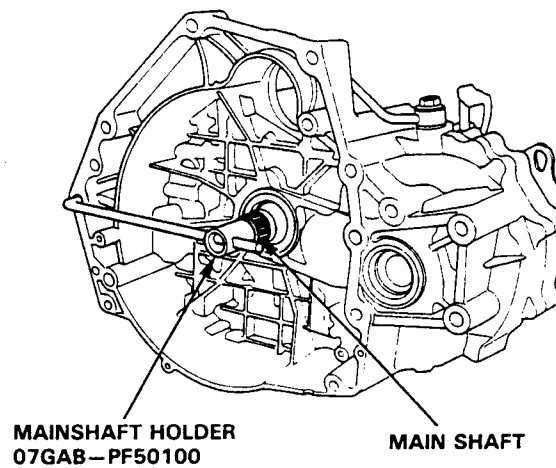

- Pry the staked edge of the lock nut flange out of the notch in the 1st clutch, and remove the mainshaft lock nut.

**CAUTION: Mainshaft lock nut has left hand threads.**

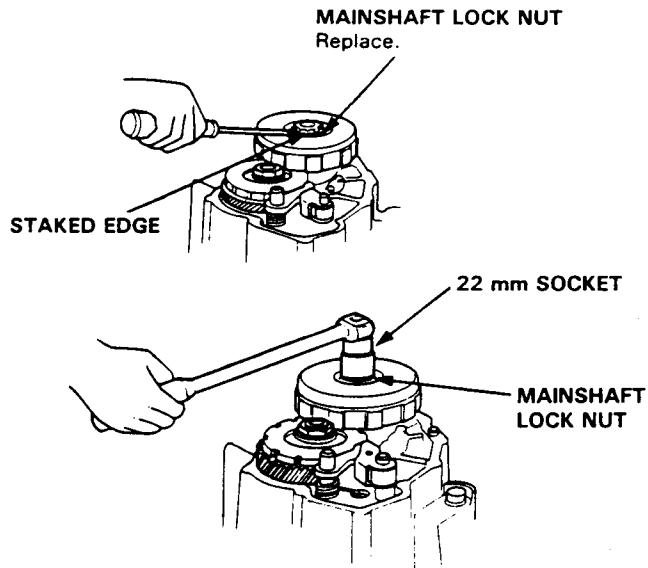

- Remove the 1st clutch.
- Remove the thrust washer, thrust needle bearing and 1st gear from the mainshaft.
- Remove the needle bearing and thrust washer from the mainshaft.

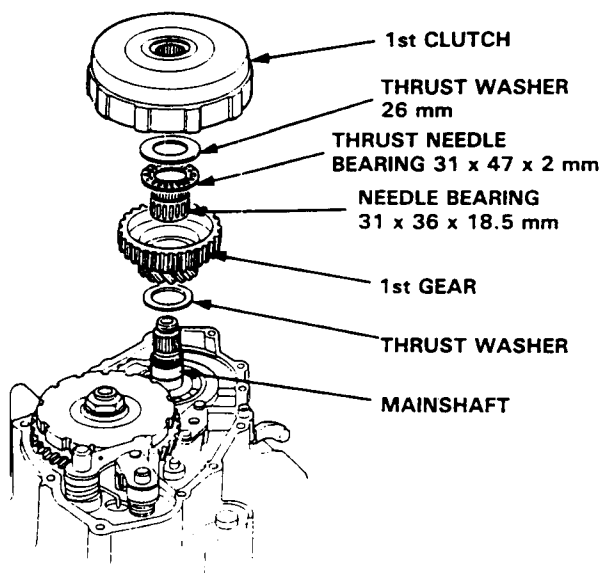

- Pry the staked edge of the lock nut out of the notch in the parking gear.

- Remove the countershaft lock nut.

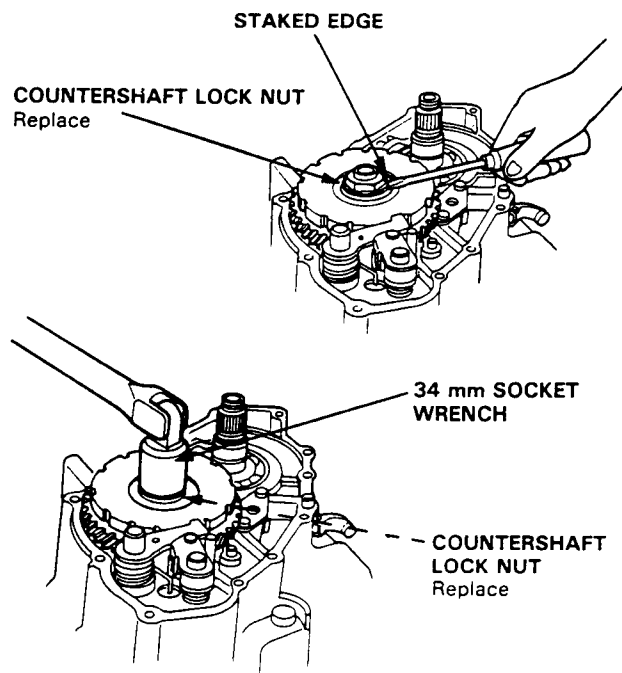

- Remove the mainshaft holder.
- Move the control shaft and release the transmission from PARK.
- Remove the parking pawl, shaft, stopper pin and spring.

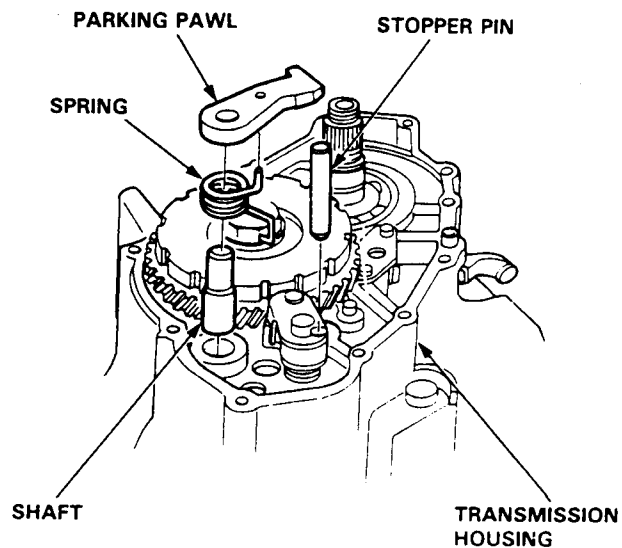

(cont'd)



# Transmission Housing

## Removal (cont'd)

14. Remove the parking gear and countershaft 1st gear as a unit with the bearing puller.

NOTE: Install the collar on the countershaft to prevent it from damage.

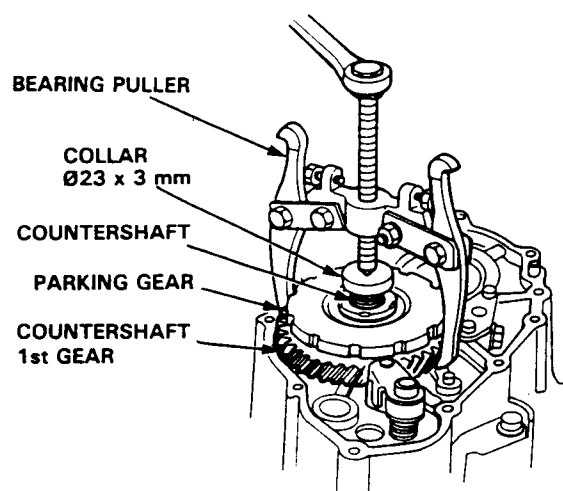

15. From the countershaft, remove the needle bearing and 1st gear collar. From the mainshaft, remove the 1st gear collar and O-rings.

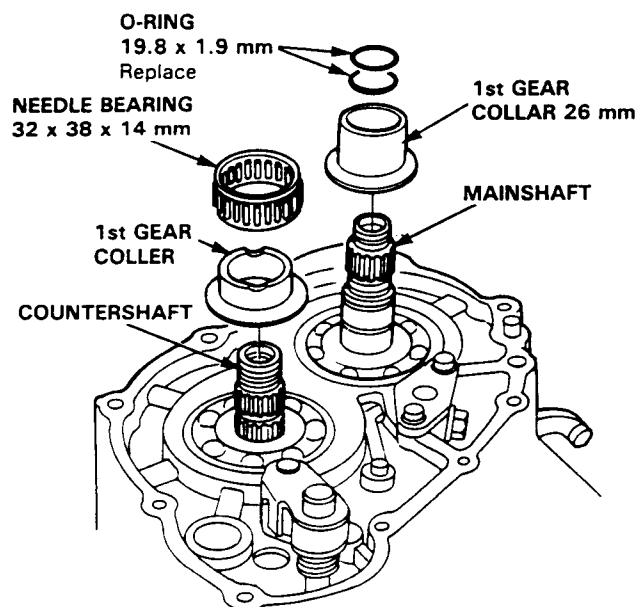

16. Align the control shaft spring pin with the cutout in the transmission housing.

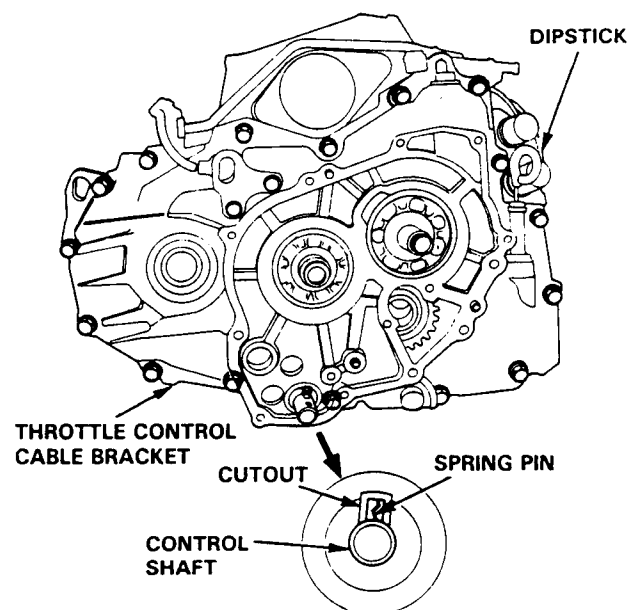

17. Bend down the tab on the lock plate under the parking shift arm bolt.

18. Remove the bolt, then remove the parking shift arm, parking brake stopper and spring from the control shaft.

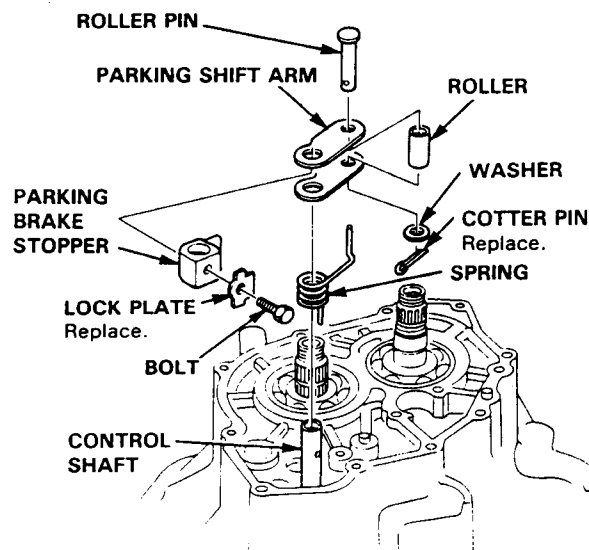

19. Bend down the tab on the throttle control lever-bolt lock plate, then remove the bolt. Remove the throttle control lever and spring from the throttle valve shaft.

NOTE: Do not loosen the throttle control cable bracket mounting bolts.

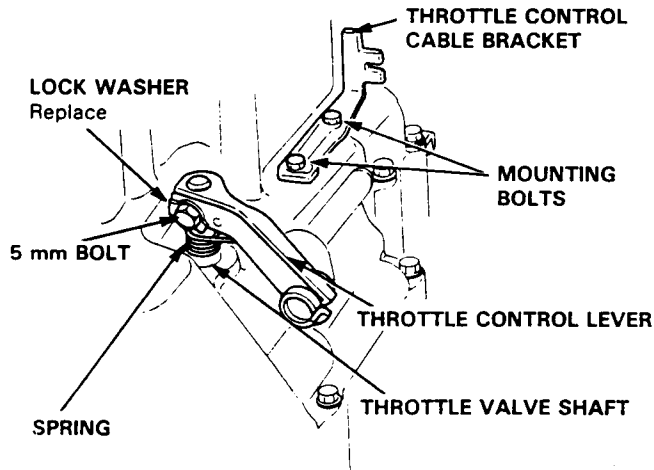

20. Remove the level gauge.

21. Remove the 10 x 1.25 mm bolts.

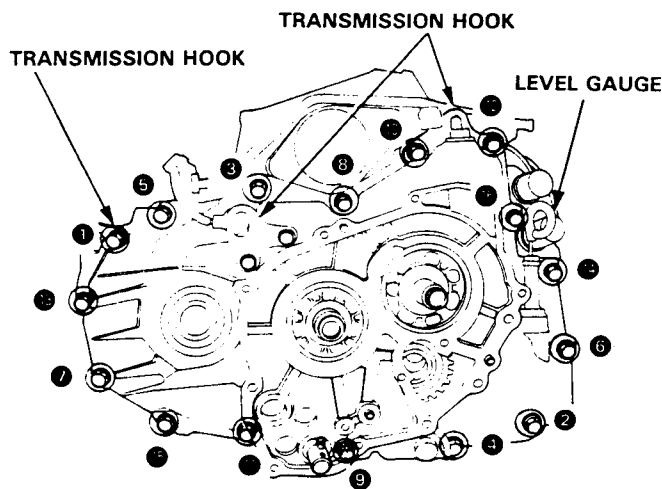

22. Install the housing puller over the countershaft with three bolts and tighten securely. Then screw in the puller bolt against the end of the countershaft until the transmission housing comes loose.

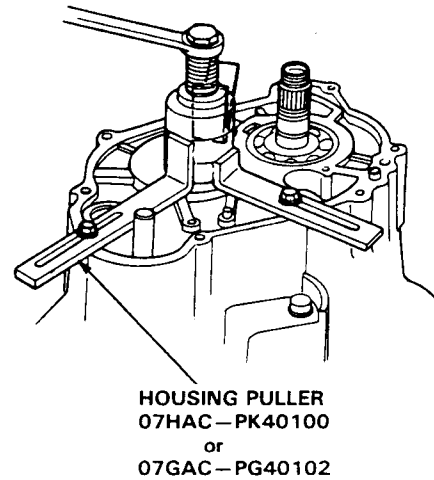

23. Remove the puller and separate the housings.

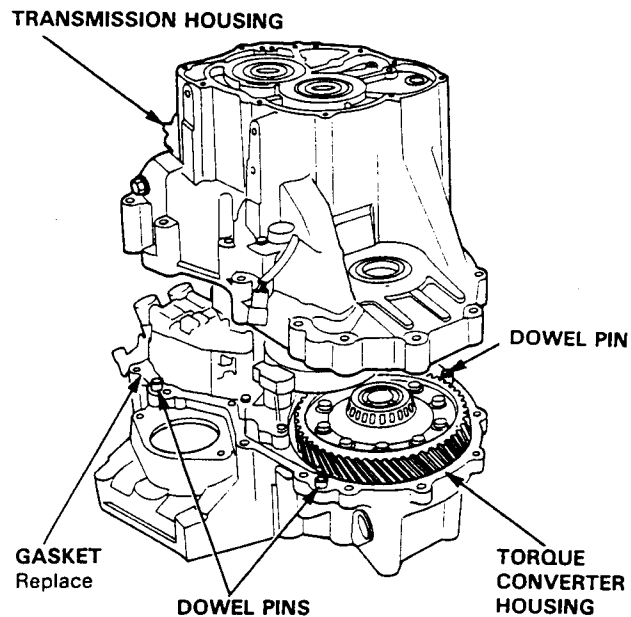

24. Remove the gasket and the dowel pins.

## Mainshaft/Countershaft

### Removal

1. Remove the reverse gear collar, countershaft reverse gear and needle bearing.
2. Bend down the tab on the lock plate and remove the bolt from the reverse shift fork.
3. Remove the reverse shift fork and reverse gear selector as a unit.
4. Remove the selector hub, countershaft 4th gear, needle bearing and distance collar.

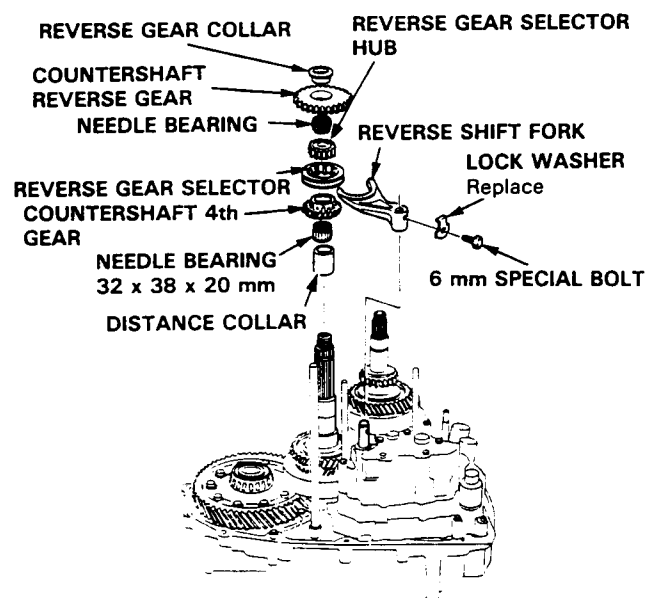

5. Remove the mainshaft and countershaft together.

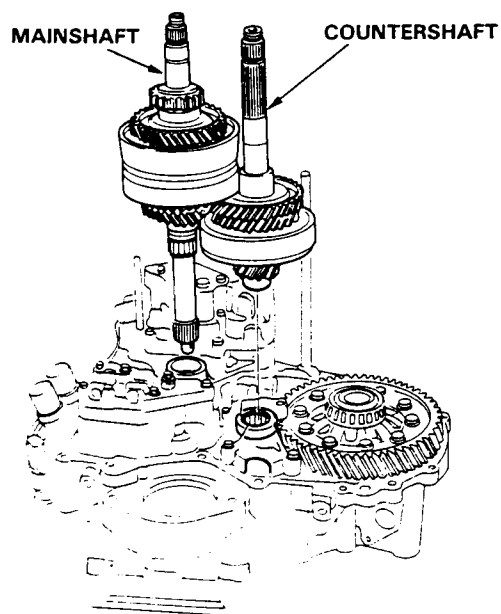

## Main Valve Body

### Removal

1. Bend down the tabs on the lock plates, remove the bolts holding the speed pulser rotor to the torque converter housing, and remove the speed pulser rotor.

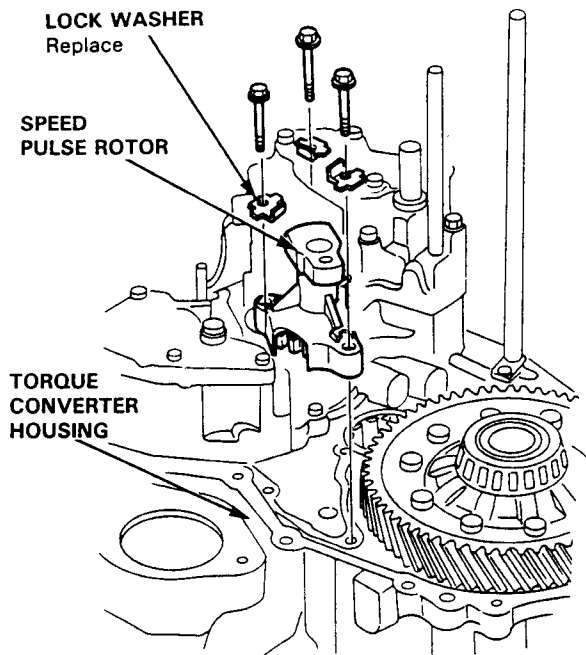

### Disassembly/Inspection

NOTE: Clean all parts with solvent and dry with compressed air.

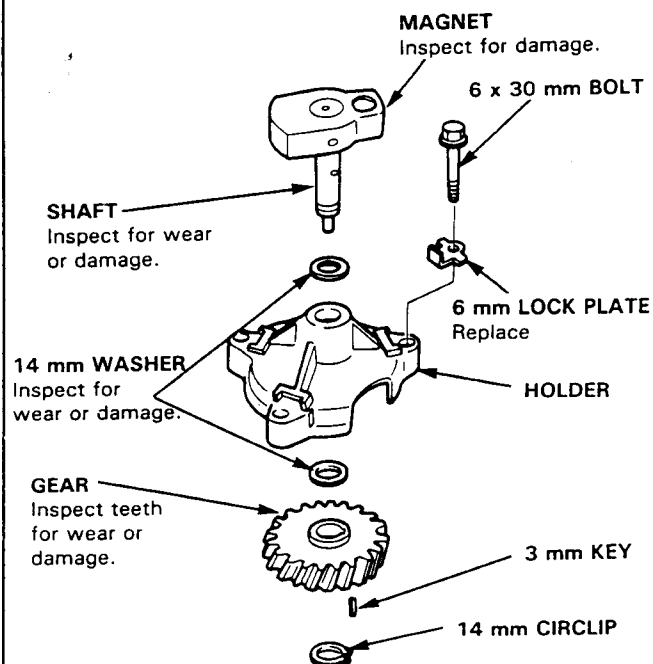

## Shift Control Solenoid Valve

### Removal

1. Remove the mounting bolts, and remove the connector and the rubber seal. Then extract the harness and connector of the shift control solenoid valve assembly to ward the inside.
2. Remove the mounting bolts, and remove the shift control solenoid valve A from the servo valve body. Then remove the shift control solenoid valve B from the main valve body.

**NOTE:** Remove the harness of the shift control solenoid valve assembly into which the connector and connector are incorporated without disassembly.

- Test page 14-65.

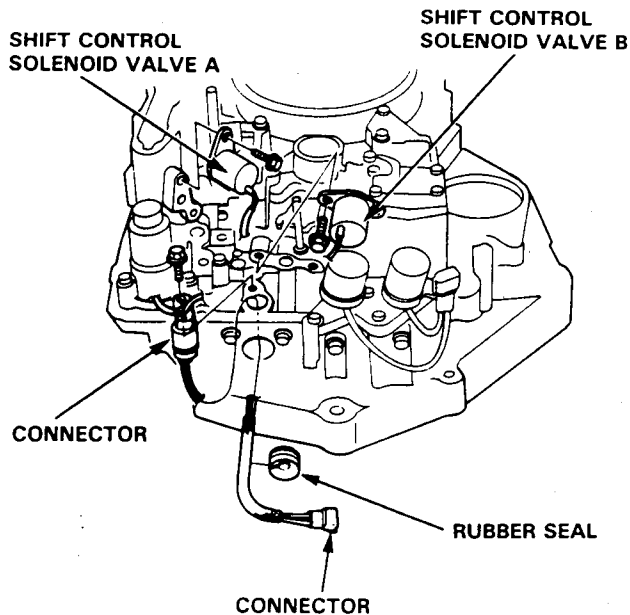

## Main Valve Body

### Removal

1. Remove the 1st, 3rd and 4th clutch feed pipes.

**CAUTION:** Do not remove feed pipes by force.

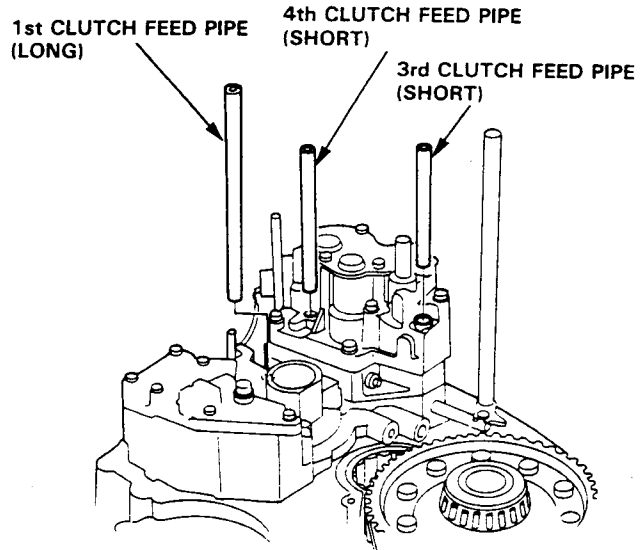

2. Remove the 2nd accumulator body, spring and piston from the torque converter housing.

**CAUTION:** Accumulator body is spring loaded; to prevent stripping the threads in the torque converter housing, press down on the accumulator body while unscrewing the bolts in a crisscross pattern.

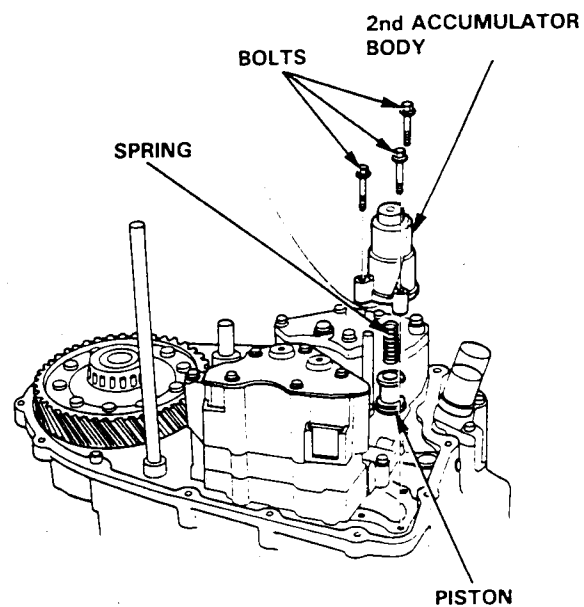

(cont'd)

# Main Valve Body

## Removal (cont'd)

3. Remove the baffle plate and accumulator cover.

**CAUTION:** Accumulator cover is spring loaded; to prevent stripping the threads in the torque converter housing, press down on the accumulator cover while unscrewing the bolts in a crisscross pattern.

4. Remove the accumulator springs.

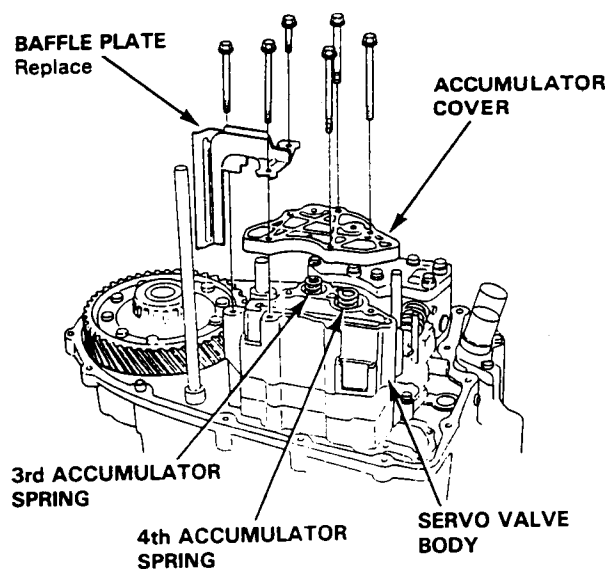

5. Remove the fore bolts and servo valve body assembly.

**NOTE:** Do not forget to remove the bolts in the oil strainer chamber.

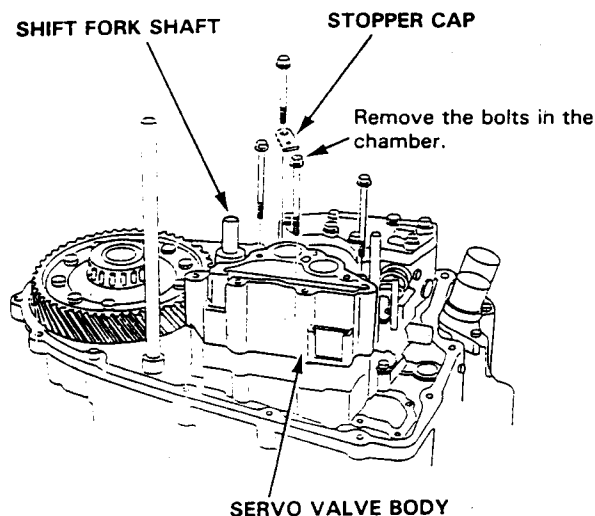

6. Remove the filter screen, magnet, 3rd accumulator piston, 4th accumulator piston, shift fork shaft and spring.

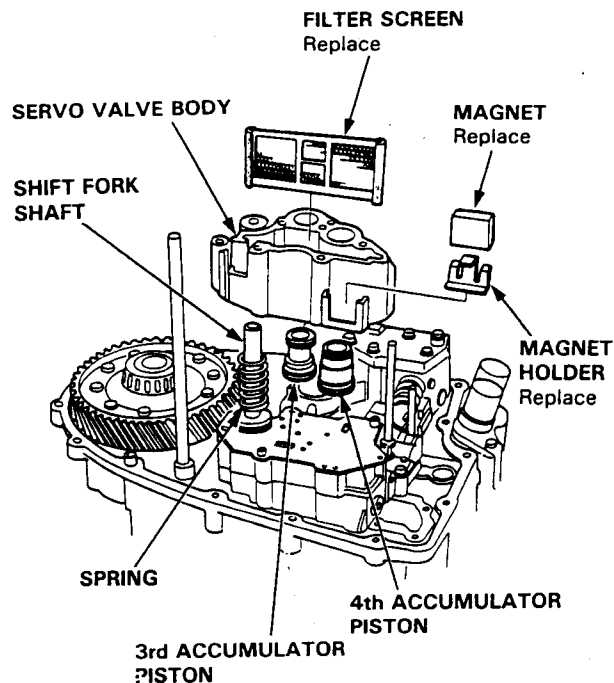

7. Remove the servo separator plate and dowel pins.

**NOTE:** With the dowel pins removed the secondary valve body can be accidentally shifted out of position; take care not to lose the check balls and check ball spring in the oil passage.

8. Remove the E-clip, then remove the throttle control shaft from the secondary separator plate.

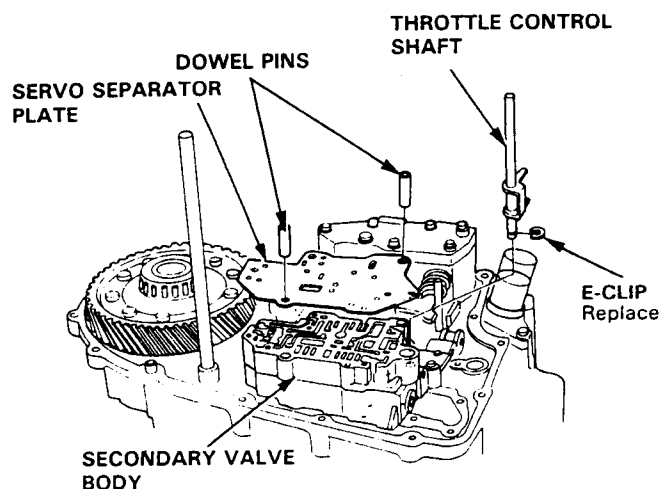

9. Remove the steel balls, ball spring and secondary filters from the oil passages of the secondary valve body assembly.

**CAUTION:** Do not use a magnet to remove the steel balls; it may magnetize the balls.

10. Remove the secondary valve body assembly.

11. Remove the secondary separator plate.

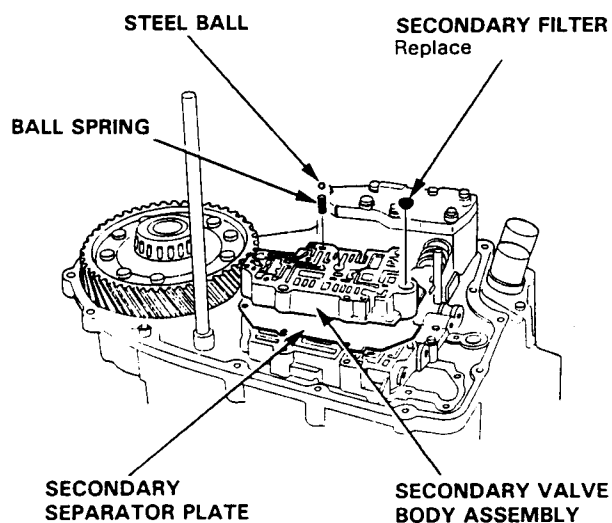

12. Remove the 7 bolts, lock-up timing valve body assembly, lock-up timing valve separator plate and 2 dowel pins from the regulator valve body assembly.

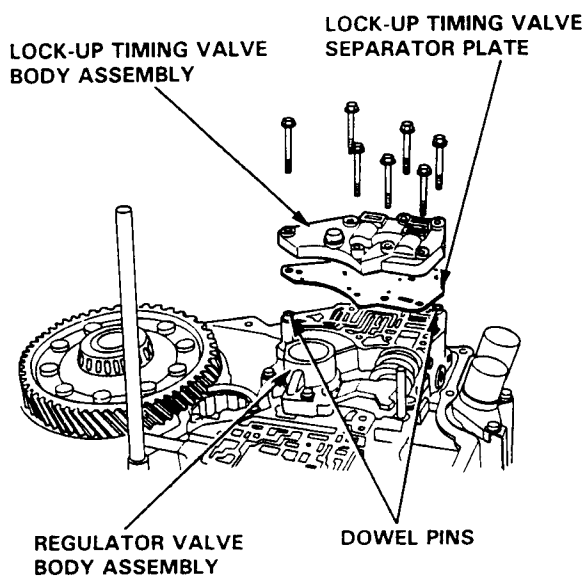

13. Remove the bolt from the regulator valve body assembly and remove the regulator valve body.

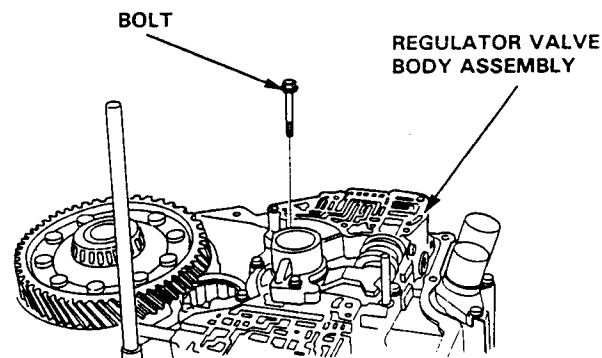

14. Remove the stator shaft arm, dowel pins and stop pin.

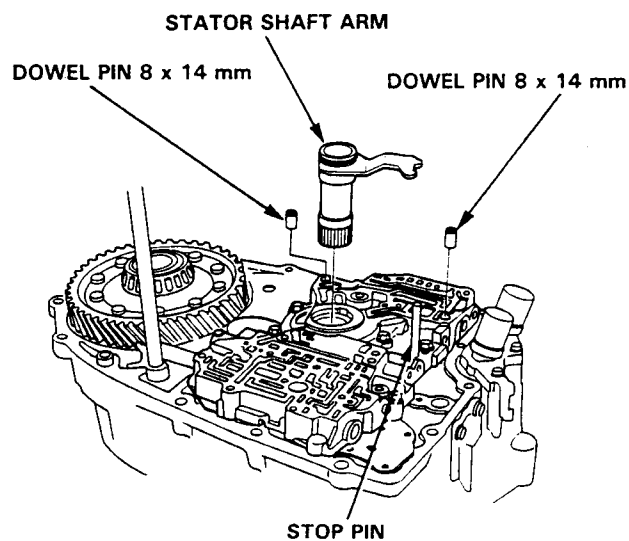

(cont'd)

# Main Valve Body

## Removal (cont'd)

15. Remove the cotter pin, washer, rollers, and pin from the manual valve.

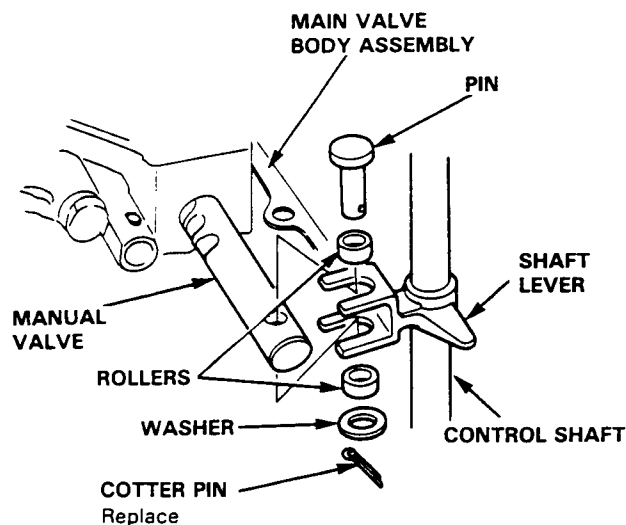

16. Remove the 4 steel balls and 5 bolts from the main valve body assembly and remove the main valve body assembly.

NOTE: Take care not to lose the torque converter check valve and spring.

CAUTION: Do not use a magnet to remove the steel balls; it may magnetize the balls.

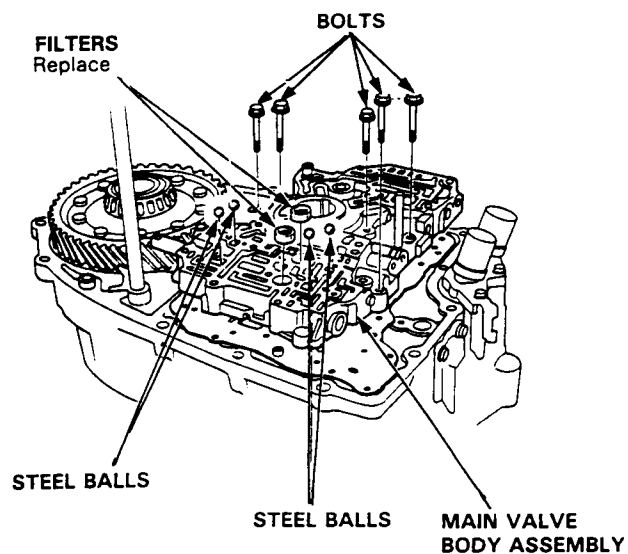

17. Remove the pump gears and shaft.

18. Remove the main separator plate, dowel pins, check valve, and spring.

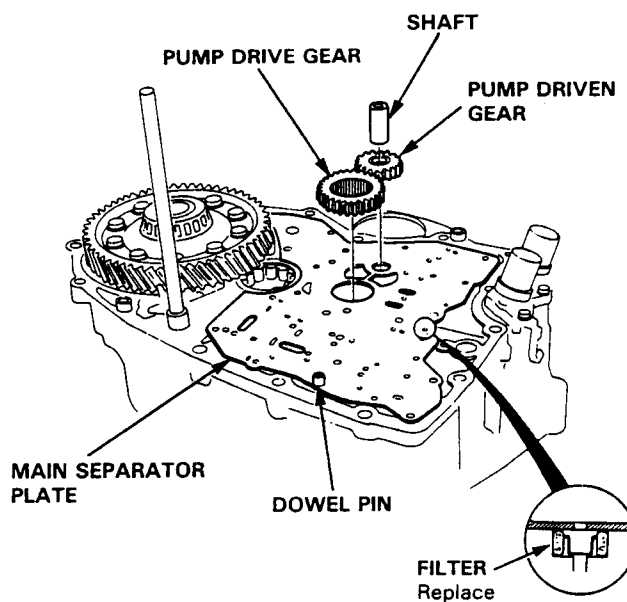

NOTE: Take care not to damage the filter under the main separator plate.

## Control Shaft

### Removal

1. Bend down the tab on the lock plate under the bolt in the control lever, then remove the bolt and lever.

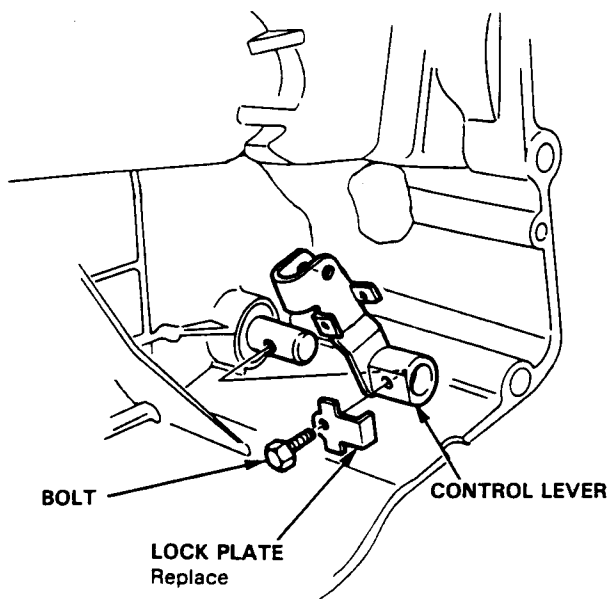

2. Remove the control shaft.

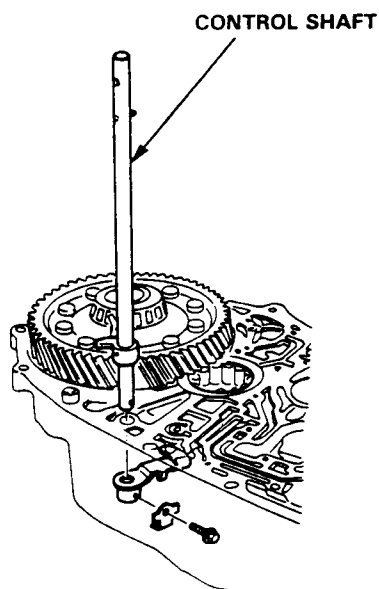

## One-Way Clutch/ Parking Gear

### Disassembly/Inspection

1. Separate the countershaft 1st gear from the parking gear by turning the parking gear in the direction shown.

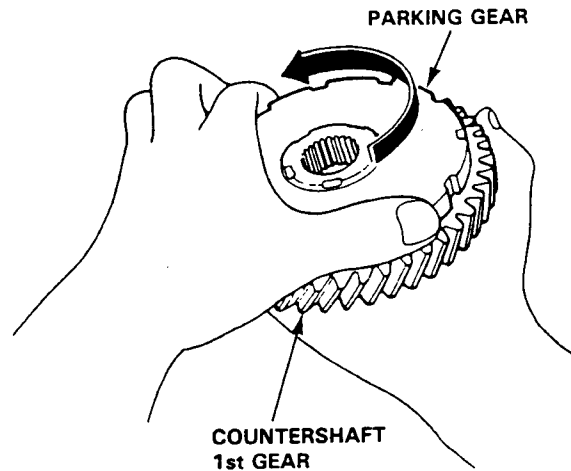

2. Remove the one-way clutch by prying it up with the end of a screwdriver.

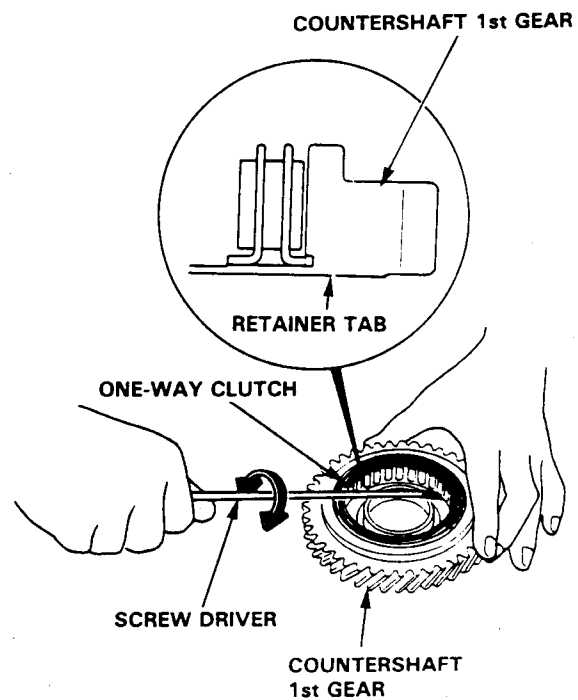

(cont'd)



# One-Way Clutch/Parking Gear

## Disassembly/Inspection (cont'd)

Inspect the parts as follows:

Inspect the parking gear for wear or scoring

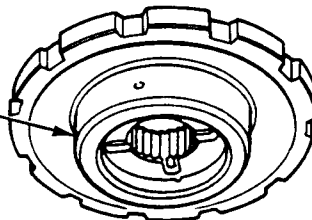

Inspect the one-way clutch for damage or faulty movement

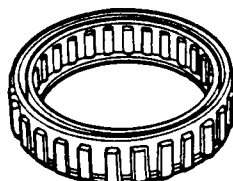

Inspect the counter-shaft 1st gear for wear or scoring

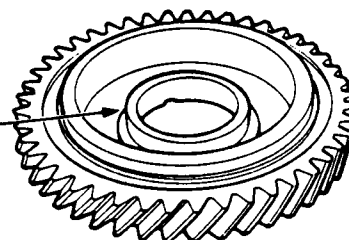

3. After the parts are assembled, hold the counter-shaft 1st gear and turn the parking gear in direction shown to be sure it turns freely.

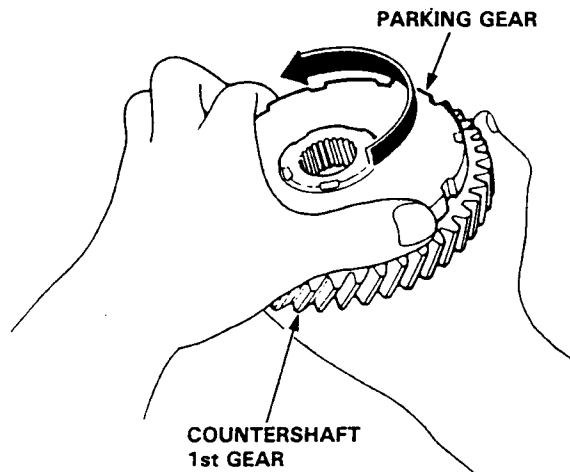

# Main Valve Body

## Disassembly

### NOTE:

- Clean all parts thoroughly in solvent or carburetor cleaner, and dry with compressed air. Blow out all passages.
- Replace valve body as an assembly if any parts are worn or damaged.
- Check all valves for free movement. If any fail to slide freely, see Valve Body Repair on page
- See Section 3 for spring specifications.
- Coat all parts with ATF before reassembly.

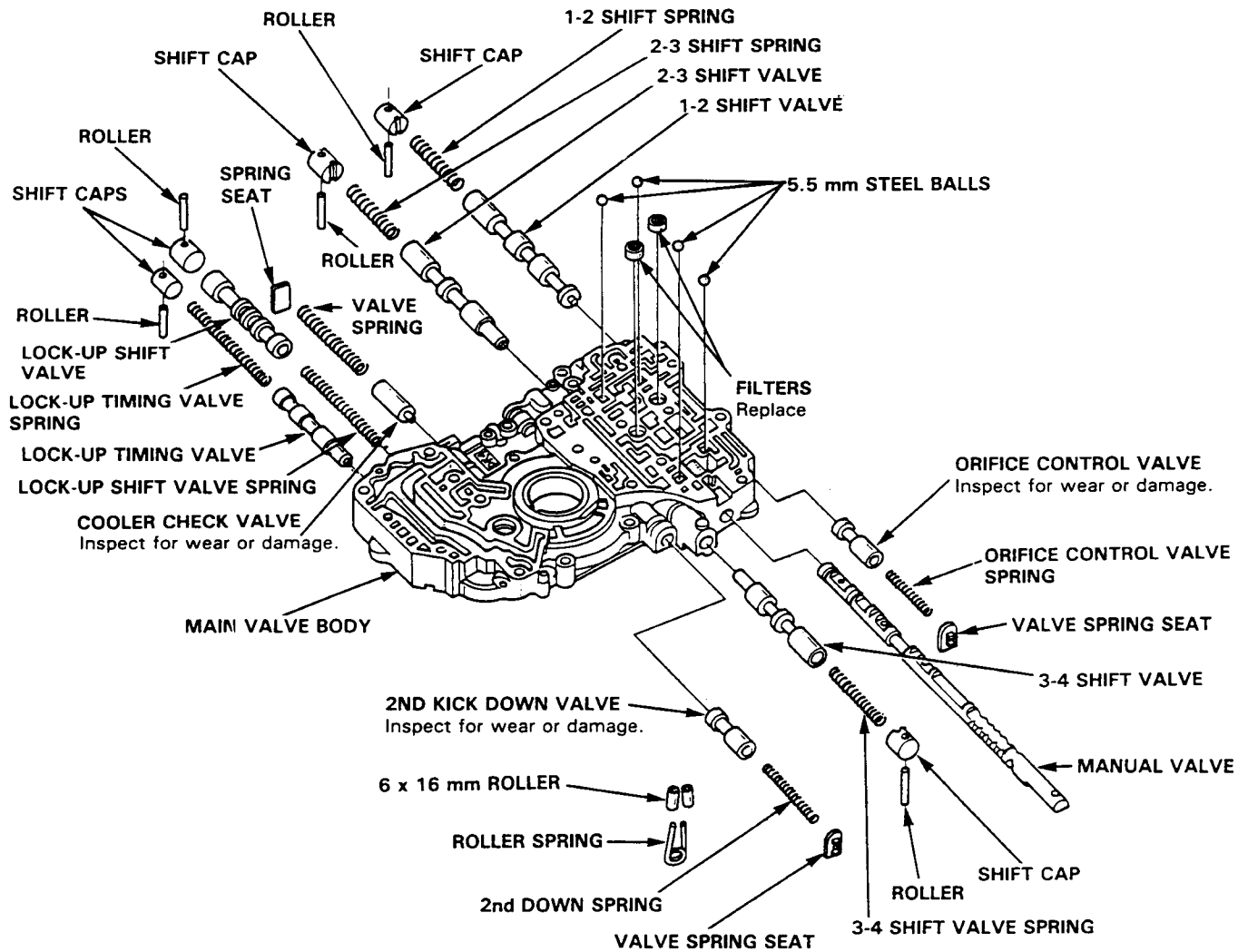

# Secondary Valve Body

## Disassembly/Inspection/Reassembly

**NOTE:**

- Clean all parts thoroughly in solvent or carburetor cleaner, and dry with compressed air.  
Blow out all passages.
- Check all valves for free movement. If any fail to slide freely, see Valve Body Repair on page
- See Section 3 for any spring specifications which are not listed below.
- Replace as assembly if any parts are worn or damaged.

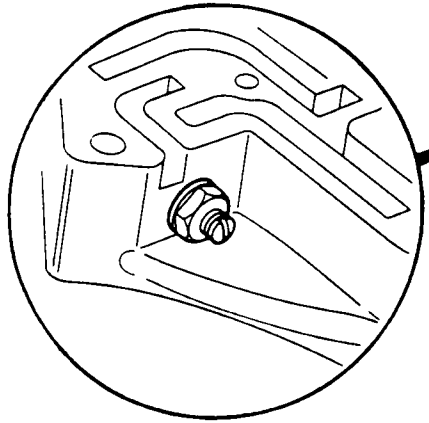
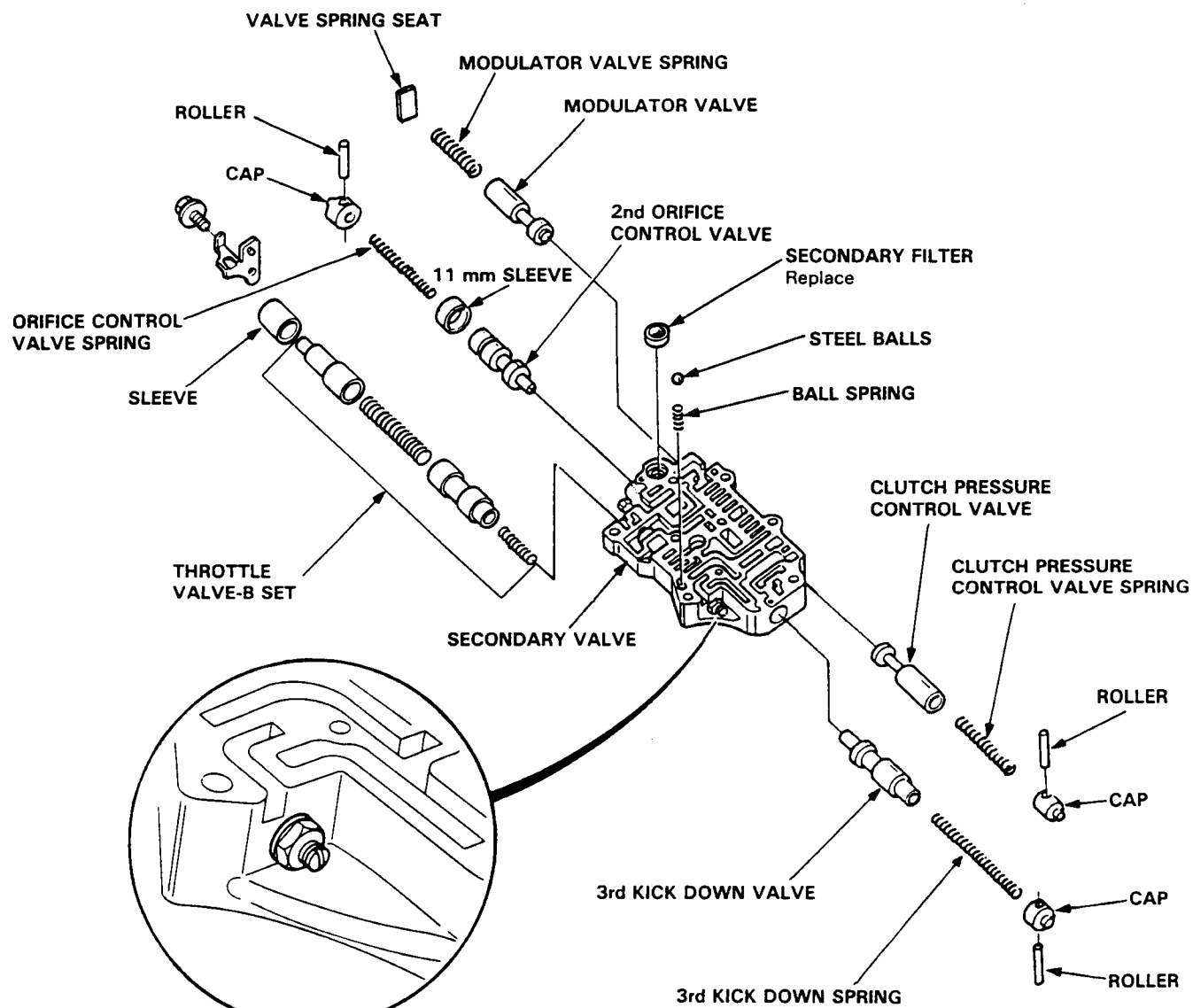

**THROTTLE PRESSURE BOLT B**  
 NOTE: Do not adjust or remove this bolt; it is adjusted at the factory for proper shift point.

# Valve Body

## Repair

**NOTE:** This repair is only necessary if one or more of the valves in a valve body do not slide smoothly in their bores. You may use this procedure to free the valves in the main valve body, regulator valve body, lock-up timing valve body and servo valve body.

1. Soak a sheet of #600 abrasive paper in ATF for about 30 minutes.
2. Carefully tap the valve body so the sticking valve drops out of its bore.

**CAUTION:** It may be necessary to use a small screwdriver to pry the valve free. Be careful not to scratch the bore with the screwdriver.

3. Inspect the valve for any scuff marks. Use the ATF-soaked #600 paper to polish off any burrs that are on the valve, then wash the valve in solvent and dry it with compressed air.
4. Roll up half a sheet of ATF-soaked paper and insert it in the valve bore of the sticking valve. Twist the paper slightly, so that it unrolls and fits the bore tightly, then polish the bore by twisting the paper as you push it in and out.

**CAUTION:** The valve body is aluminum and doesn't require much polishing to remove any burrs.

ATF-soaked  
#600 abrasive  
paper

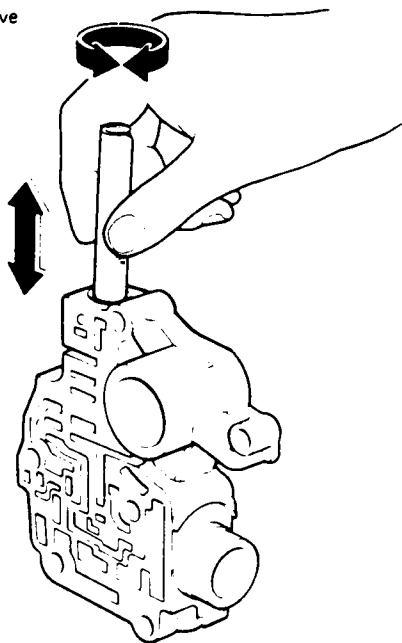

5. Remove the #600 paper and thoroughly wash the entire valve body in solvent, then dry with compressed air.
6. Coat the valve with ATF then drop it into its bore. It should drop to the bottom of the bore under its own weight. If not, repeat step 4, then retest.

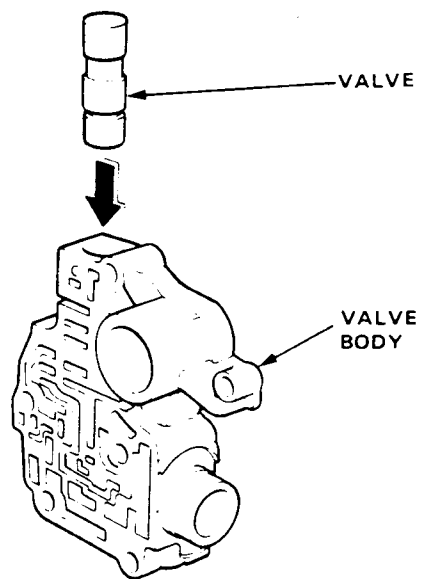

7. Remove the valve and thoroughly clean it and the valve body with solvent. Dry all parts with compressed air, then reassemble using ATF as a lubricant.

# Main Valve Body

## Reassembly

NOTE: Coat all parts with ATF before assembling.

1. Install the 3-4 shift valve, 3-4 shift valve spring and shift cap in the main valve body and secure with the roller.

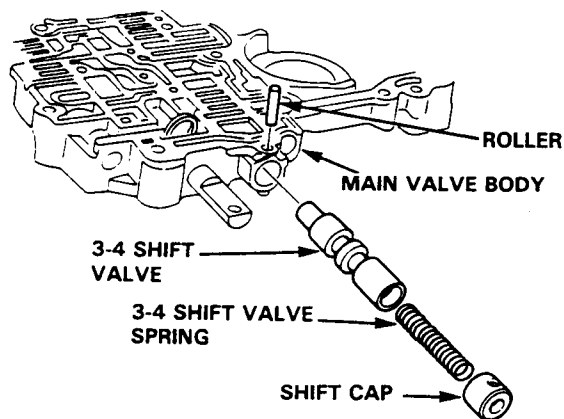

2. Install the 1-2 and 2-3 shift valves in the main valve body in the same procedure as for 3-4 shift valve.
3. Install the manual valve, 6 x 16 mm rollers and spring.

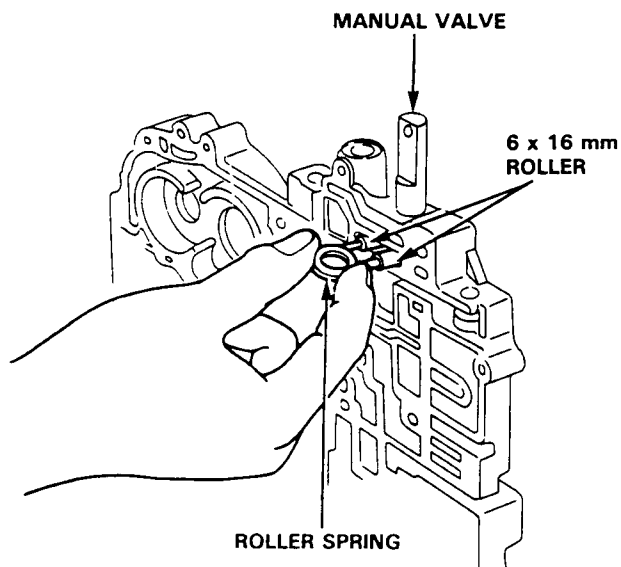

4. Set the relief spring in the relief valve and install it in the main valve body.
5. Install the spring with a screwdriver, then install the check valve cap with the cutout aligned with the screwdriver.

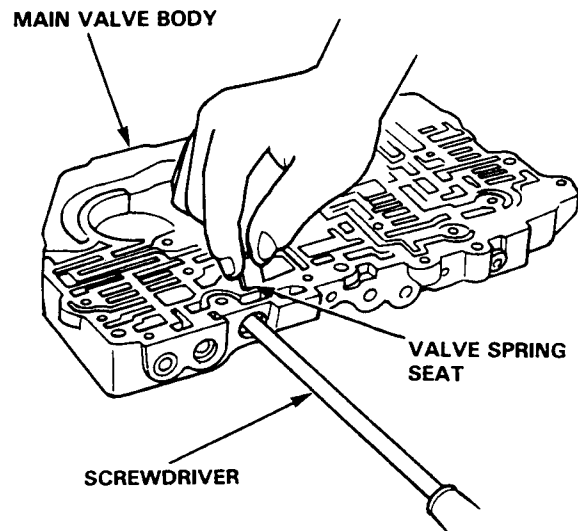

6. Install the orifice control valve in the main valve body in the same manner described in step 5.

# Oil Pump

## Inspection

1. Install the pump gears and shaft in the main valve body.

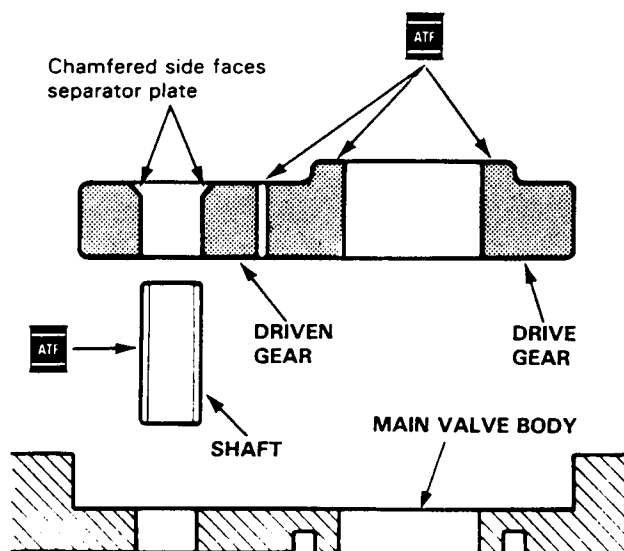

2. Install the oil pump shaft and measure the side clearance of the drive and driven gears.

**Pump Gears Side (Radial) Clearance:**  
**Standard (New): Drive gear (diameter)**  
0.210–0.265 mm  
(0.0083–0.0104 in)

**Driven gear (radius)**  
0.035–0.063 mm  
(0.0014–0.0025 in)

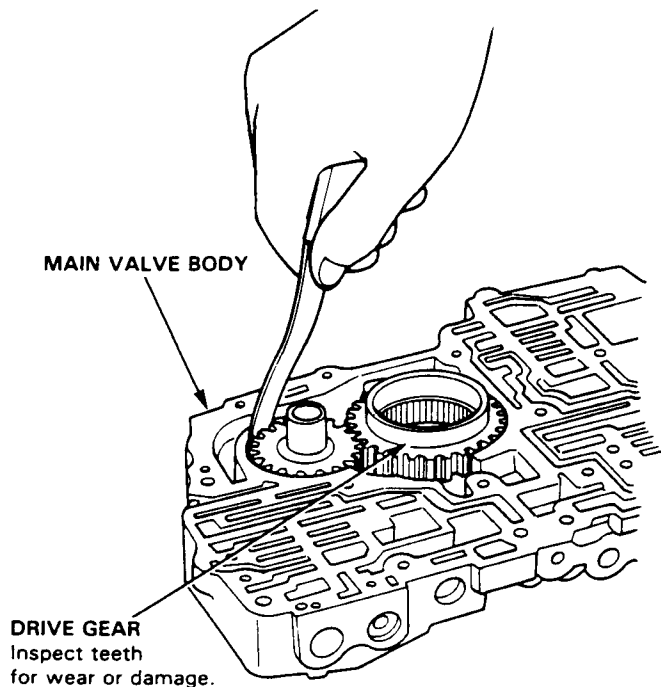

3. Measure the thrust clearance of the driven gear-to-valve body.

**Drive/Driven Gear thrust (Axial) Clearance:**  
**Standard (New): 0.03–0.05 mm**  
(0.001–0.002 in.)  
**Service Limit: 0.07 mm (0.0028 in.)**

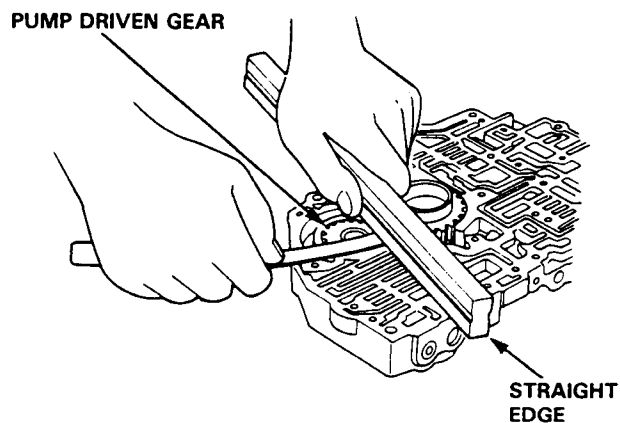

# Regulator Valve Body

## Disassembly/Inspection

### NOTE:

- Clean all parts thoroughly in solvent or carburetor cleaner, and dry with compressed air. Blow out all passages.
- Replace valve body as assembly if any parts are worn or damaged.
- Check all valves for free movement. If any fail to slide freely, see Valve Body Repair on page
- Coat all parts with ATF before reassembly.

1. Hold the retainer in place while removing the lock bolt. Once the bolt is removed, release the retainer slowly.

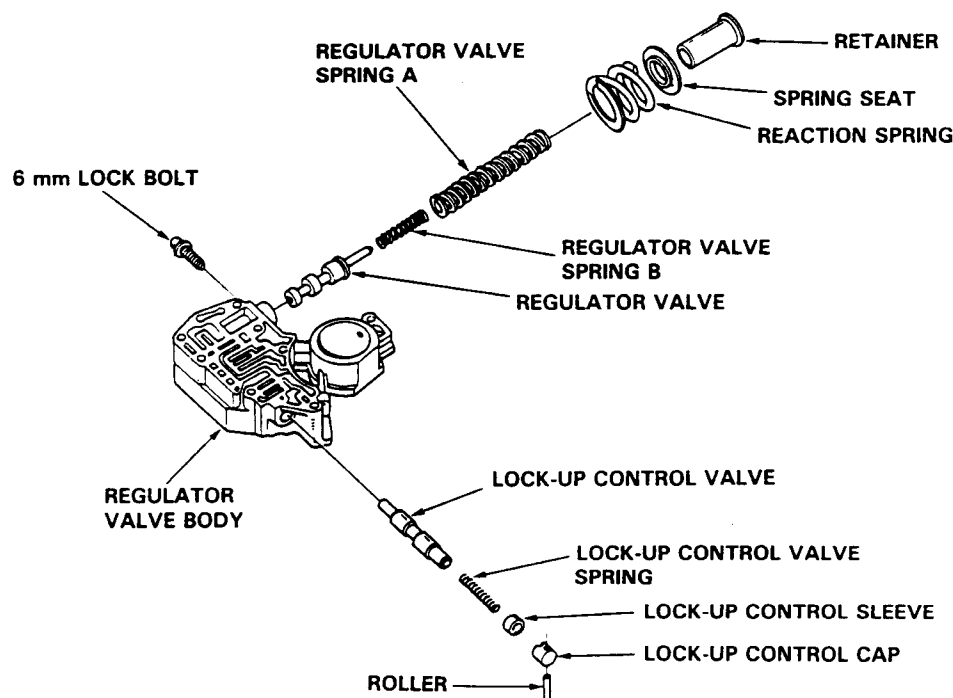

## Reassembly

1. Clean all parts thoroughly in solvent or carburetor cleaner, and dry with compressed air. Blow out all passages.
2. Coat all valves with ATF.
3. Install the pressure regulator valve, and regulator valve spring A and B.
4. Install the reaction spring, spring seat, and retainer. Align the hole in the retainer with the hole in the valve body, then press the retainer into the valve body and tighten the lock bolt.

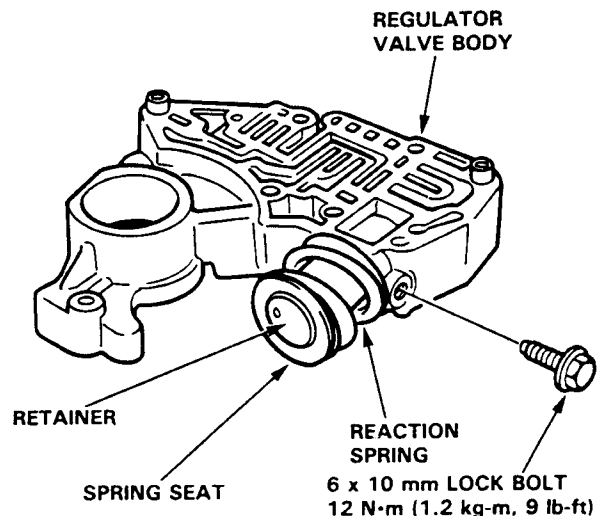

# Lock-up Timing Valve Body

## Disassembly/Inspection

### NOTE:

- Clean all parts thoroughly in solvent or carburetor cleaner, and dry with compressed air. Blow out all passages.
- Replace valve body as assembly if any parts are worn or damaged.
- Check all valves for free movement. If any fail to slide freely, see Valve Body Repair on page
- Coat all parts with ATF before reassembly.

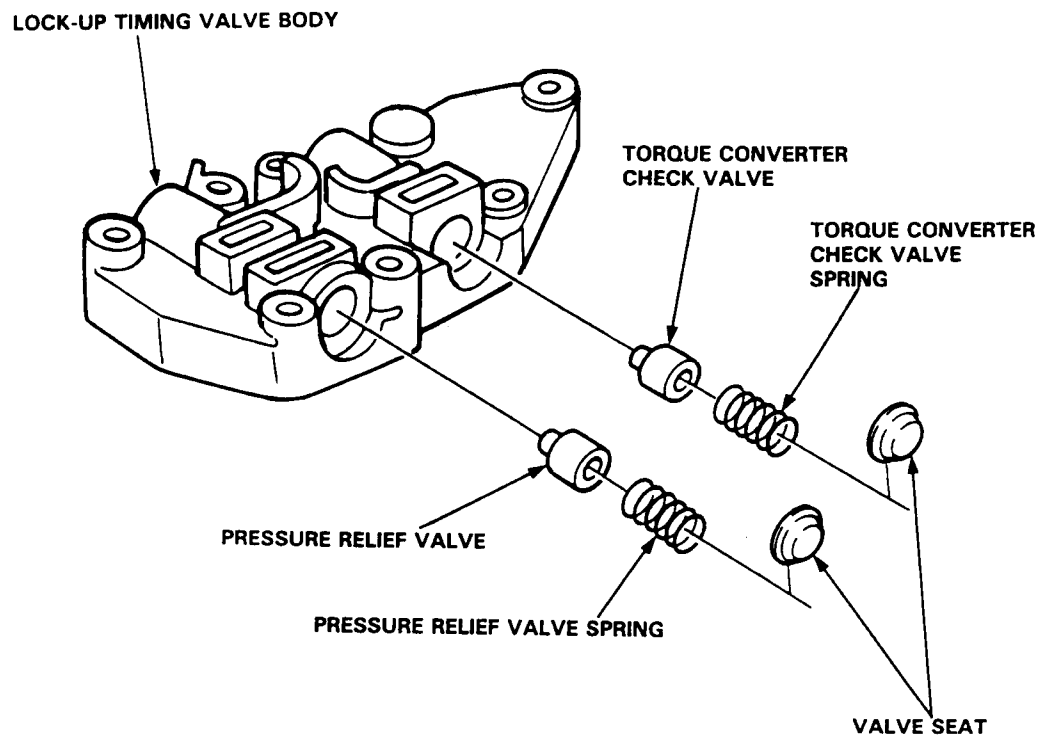



# Servo Valve Body

## Disassembly/Inspection/Reassembly

### NOTE:

- Clean all parts thoroughly in solvent or carburetor cleaner, and dry with compressed air. Blow out all passages.
- Check all valves for free movement. If any fail to slide freely, see Valve Body Repair on page
- Replace valve body as assembly if any parts are worn or damaged.

### SERVO VALVE RETURN SPRING FREE LENGTH

Standard : 40.3 mm (1.59 in)  
 Service Limit: 36.7 mm (1.44 in)  
 Accumulator Spring O.D.  
 2nd Accumulator Spring: 16.5 mm (0.65 in)  
 3rd Accumulator Spring: 16.0 mm (0.63 in)  
 4th Accumulator Spring: 18.6 mm (0.73 in)

### Accumulator Spring Free Length

2nd Accumulator Spring  
 Standard 87.7 mm (3.45 in)  
 Service Limit: 86.4 mm (3.40 in)  
 3rd Accumulator Spring  
 Standard: 78.3 mm (3.08 in)  
 Service Limit: 77.1 mm (3.04 in)  
 4th Accumulator Spring  
 Standard: 78.0 mm (3.07 in)  
 Service Limit: 76.8 mm (3.02 in)

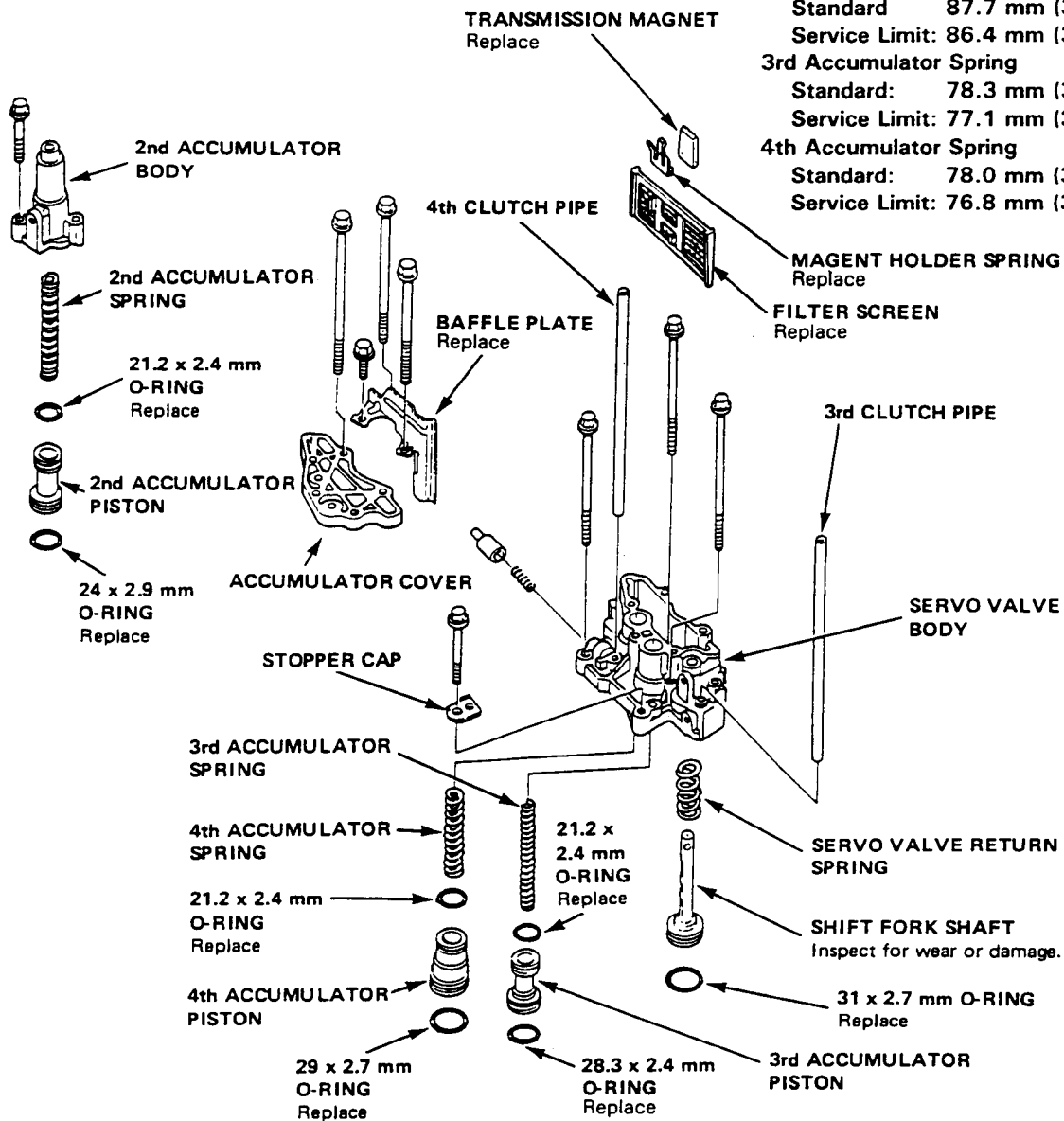

# Mainshaft

## Disassembly/Inspection/Reassembly

**NOTE:**

- Lubricate all parts with ATF during reassembly.
- Install thrust needle bearings with unrolled edge of bearing retainer facing washer.

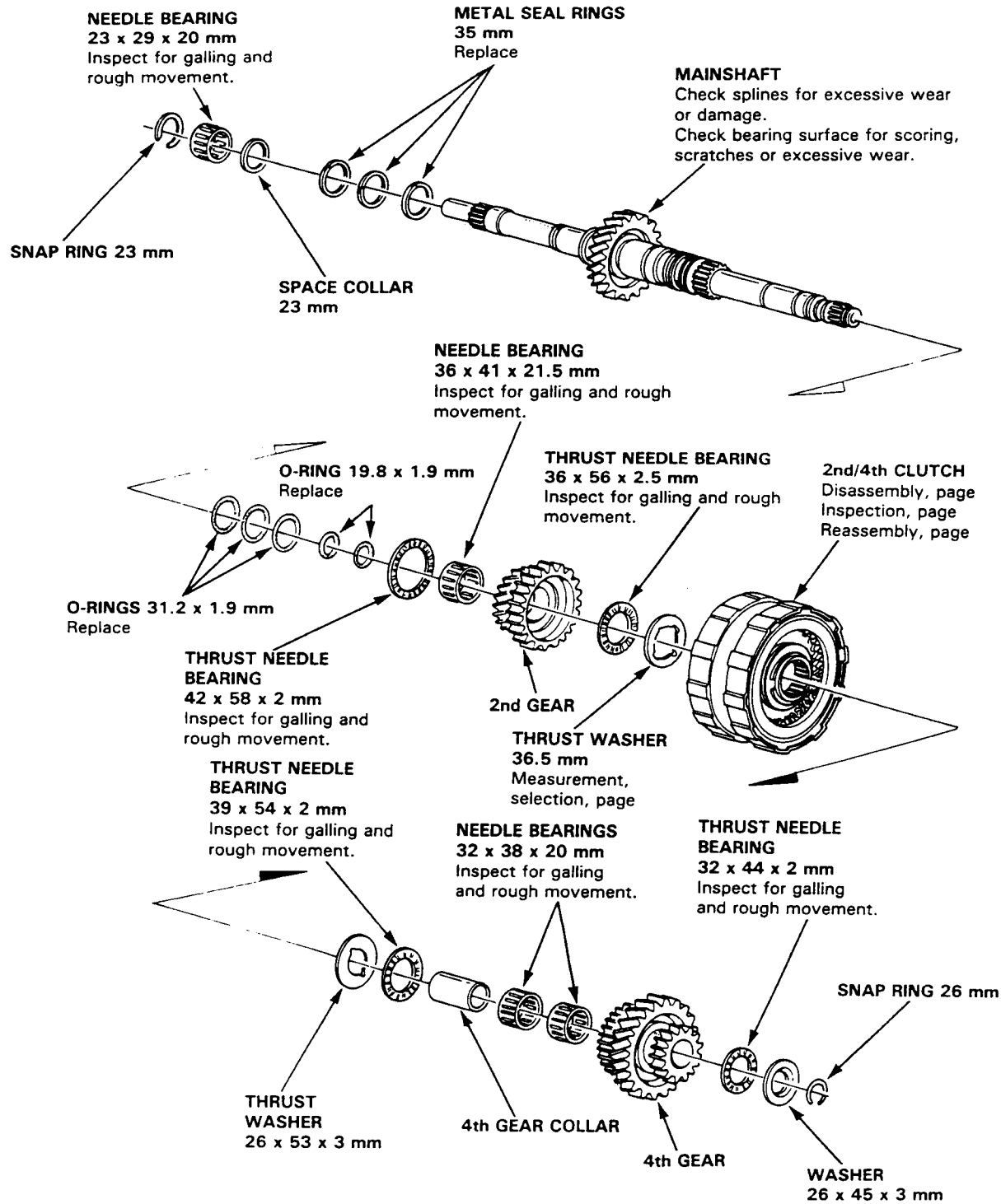

# Countershaft

## Disassembly/Inspection/Reassembly

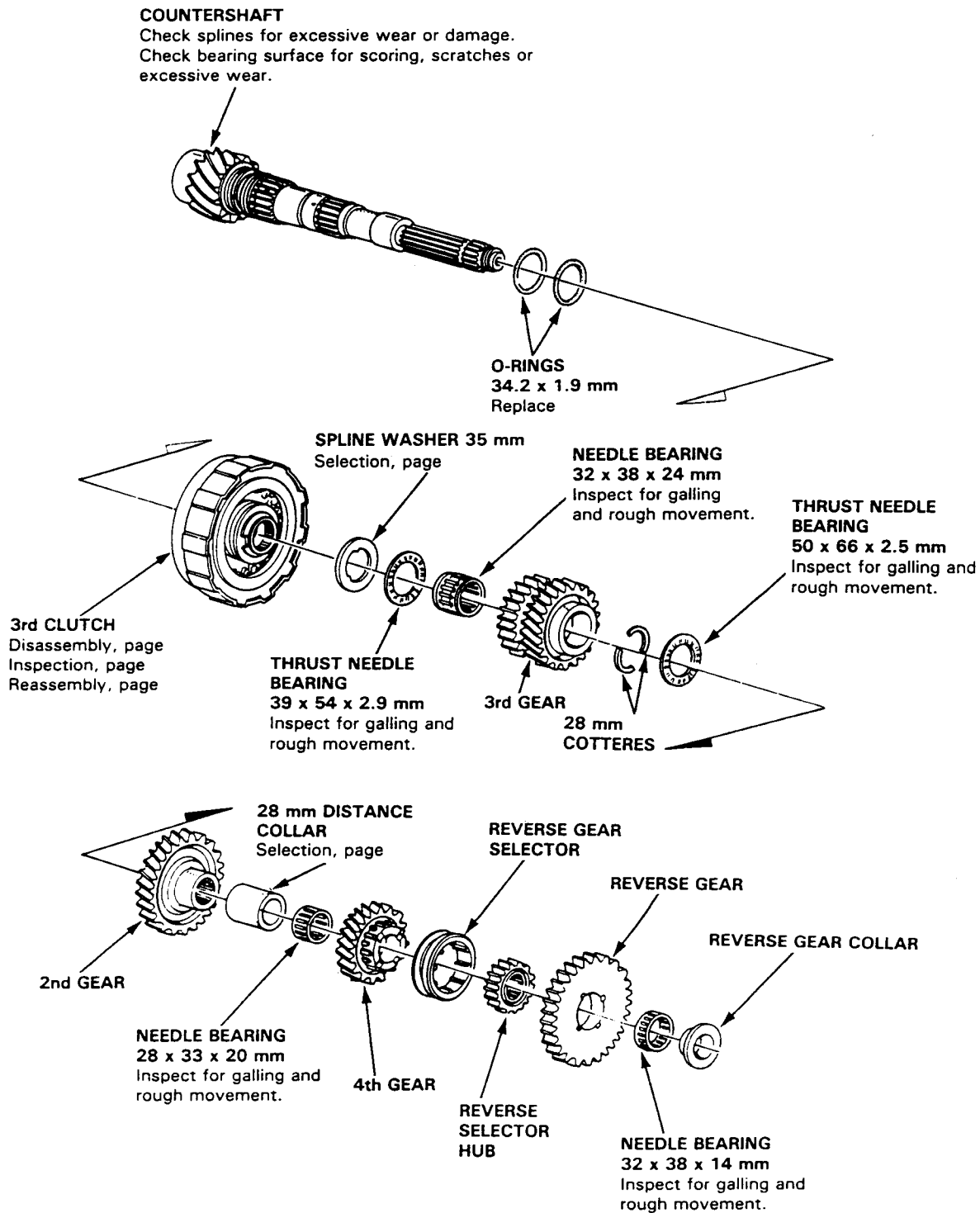

# Countershaft/Mainshaft

## Clearance Measurement

1. Remove both the mainshaft and countershaft bearings from the transmission housing.
2. Assemble the mainshaft and the countershaft including bearings and all parts shown to the right.
3. Torque the mainshaft and countershaft lock nut to 30 N·m (3.0 kg·m, 22 lb·ft).

NOTE: The countershaft lock nut has left-hand threads.

4. Measure clearances as described on the next page.



Lubricate all parts with ATF before final reassembly.

## Countershaft Assembly

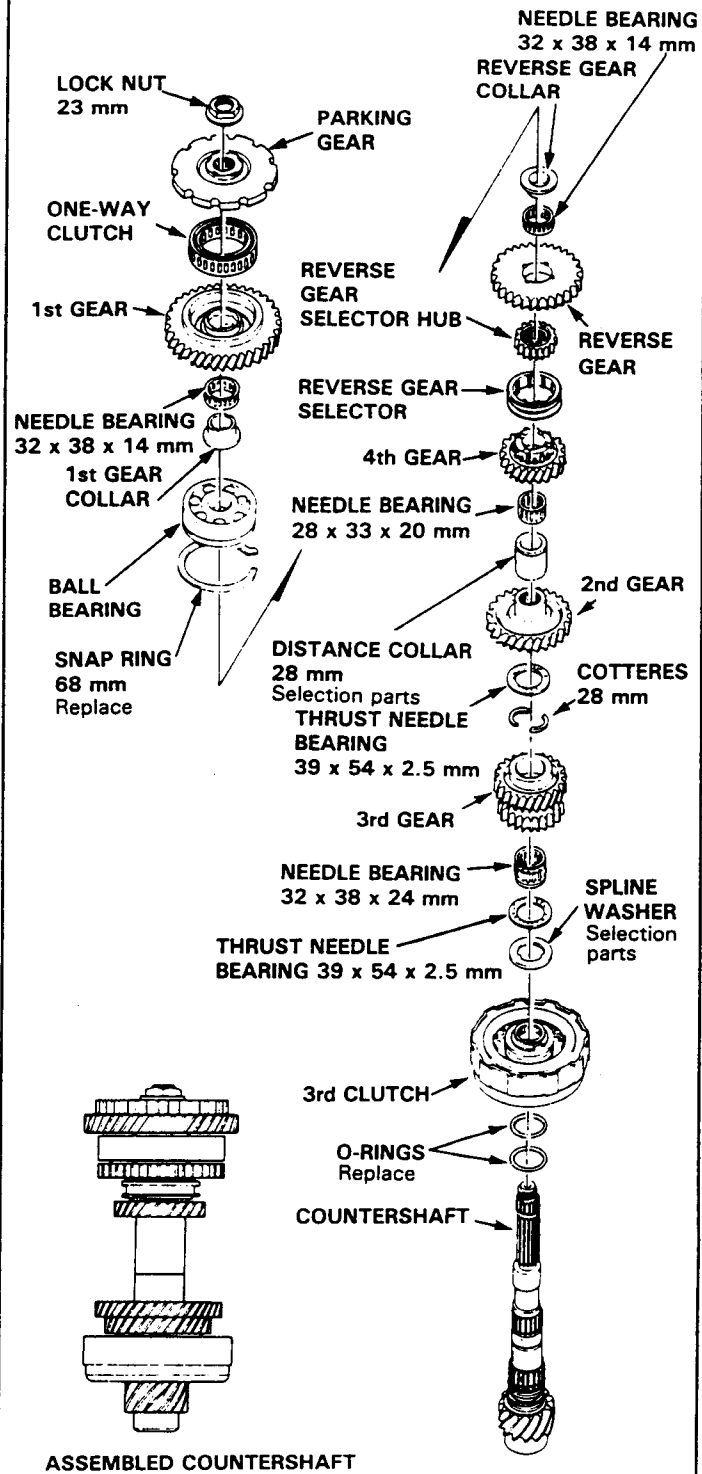

(cont'd)

# Countershaft/Mainshaft

## Clearance Measurements (cont'd)

5. On the countershaft, measure the clearance between the shoulder on the selector hub and the shoulder on 4th gear.

**Countershaft 4th Gear Clearance:**  
**Standard: 0.07–0.15 mm (0.003–0.006 in.)**

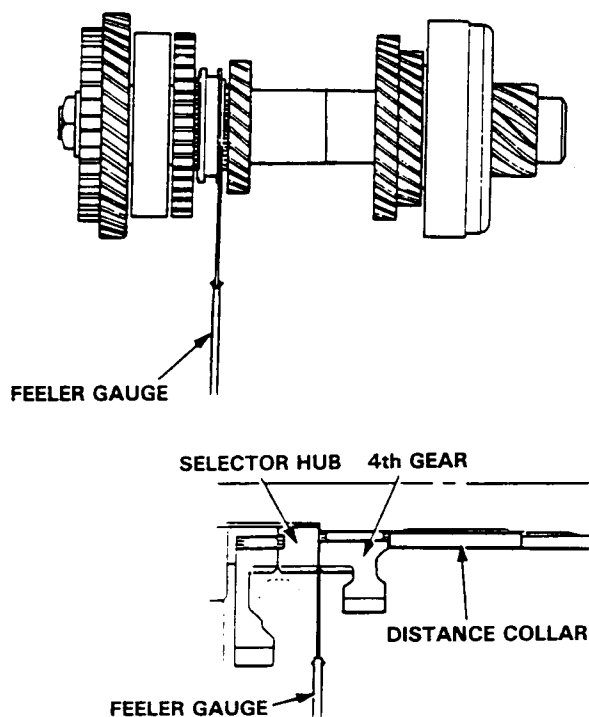

If clearance exceeds the service limit, measure the thickness of the distance collar and select one which will give the correct clearance.

**Replacement distance collar:**

P/N	THICKNESS
90503-PC9-000	38.97–39.00 mm (1.534–1.535 in)
90508-PC9-000	39.02–39.05 mm (1.536–1.537 in)
90504-PC9-000	39.07–39.10 mm (1.538–1.539 in)
90509-PC9-000	39.12–39.15 mm (1.540–1.541 in)
90505-PC9-000	39.17–39.20 mm (1.542–1.543 in)
90510-PC9-000	39.22–39.25 mm (1.544–1.545 in)
90507-PC9-000	39.27–39.30 mm (1.546–1.547 in)

6. Slide the 3rd gear out fully. Measure and record the clearance between the 2nd and 3rd gear with a feeler gauge.

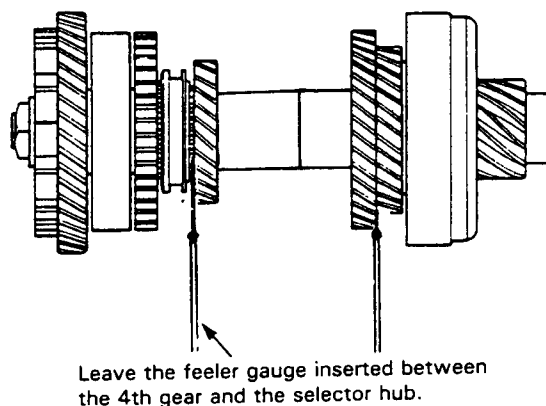

- Slide the 3rd gear in fully and again measure the clearance between 2nd and 3rd gears.
- Calculate the difference between the two readings to determine the actual clearance.

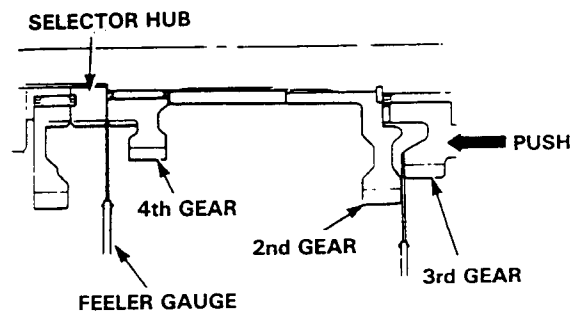

If the clearance exceeds the service limit, measure the thickness of the spline washer and select one which will give the correct clearance.

**Service Limit: 0.07–0.15 mm (0.003–0.006 in)**

P/N	THICKNESS
90411-PF4-000	2.97–3.00 mm (0.117–0.118 in)
90412-PF4-000	3.02–3.05 mm (0.119–0.120 in)
90413-PF4-000	3.07–3.10 mm (0.121–0.122 in)
90414-PF4-000	3.12–3.15 mm (0.123–0.124 in)
90415-PF4-000	3.17–3.20 mm (0.125–0.126 in)
90416-PF4-000	3.22–3.25 mm (0.127–0.128 in)
90417-PF4-000	3.27–3.30 mm (0.129–0.130 in)
90418-PF4-000	3.32–3.35 mm (0.131–0.132 in)
90419-PF4-000	3.37–3.40 mm (0.133–0.134 in)

## Mainshaft Assembly

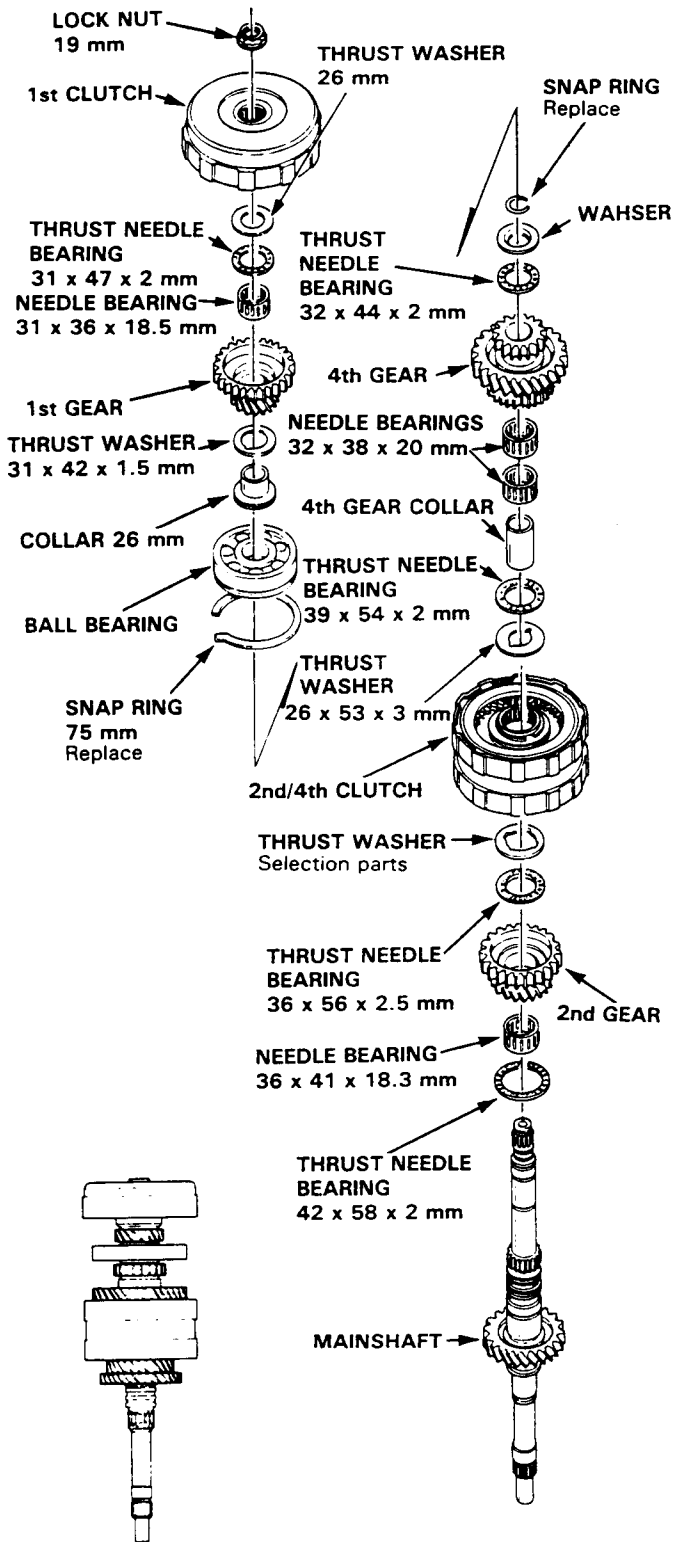

ASSEMBLED MAINSHAFT

NOTE: Make all measurements before changing the thrust washers. Recheck after making the adjustments.

- On the mainshaft measure the clearance between the shoulder of 2nd gear and main 3rd gear, the same way you did on the countershaft in step 6.

**Mainshaft 2nd Gear Clearance:**  
**Standard (New): 0.07–0.15 mm**  
 (0.003–0.006 in.)

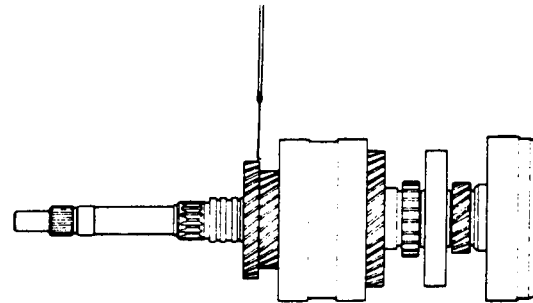

If the clearance exceeds the service limit, measure the thickness of the 2nd clutch thrust washer (36.5 mm I.D.) and select one which gives the correct clearance.

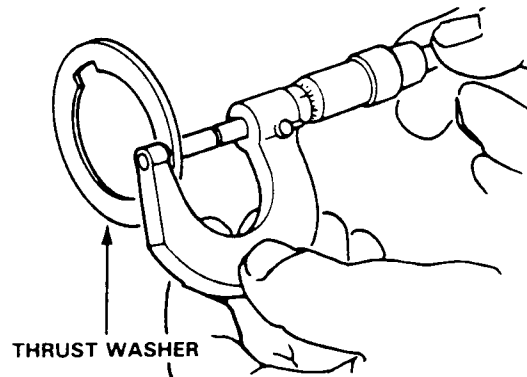

Replacement washer (36.5 mm I.D.)

P/N	THICKNESS
90441-PL5-000	3.97–4.00 mm (0.156–0.157 in)
90442-PL5-000	4.02–4.05 mm (0.158–0.159 in)
90443-PL5-000	4.07–4.10 mm (0.160–0.161 in)
90444-PL5-000	4.12–4.15 mm (0.162–0.163 in)
90445-PL5-000	4.17–4.20 mm (0.164–0.165 in)
90446-PL5-000	4.22–4.25 mm (0.166–0.167 in)
90447-PL5-000	4.27–4.30 mm (0.168–0.169 in)
90448-PL5-000	4.32–4.35 mm (0.170–0.171 in)
90449-PL5-000	4.37–4.40 mm (0.172–0.173 in)

# Clutch

## Disassembly

### 1. 1st Clutch

- 1. Remove the snap ring.
- 2. Remove the end plate, clutch discs and plates.

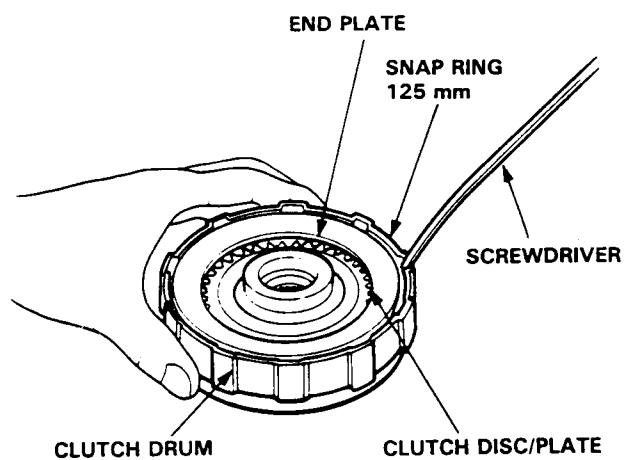

- 3. Remove the spring washer.

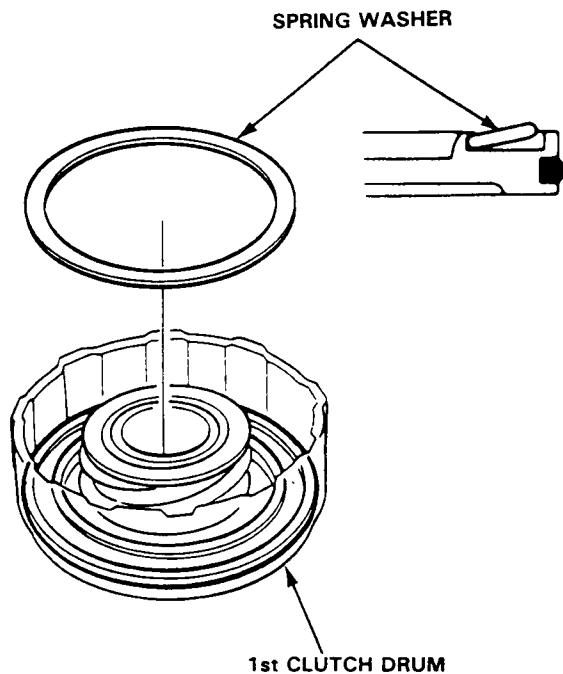

- 4. Install the clutch spring compressor as shown and compress the clutch return spring.

**CAUTION:** If either end of the compressor attachment is set over an area of the retainer which is unsupported by the spring, the retainer may be damaged.

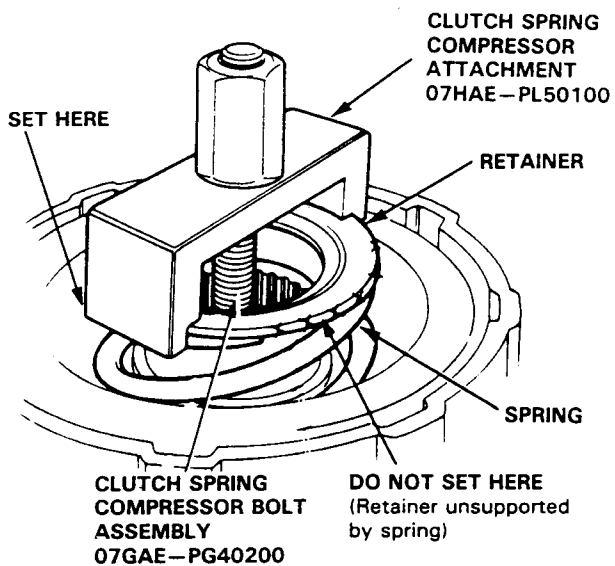

### 2. 2nd Clutch

- 1. Remove the snap ring.
- 2. Remove the end plate, clutch discs and plates.

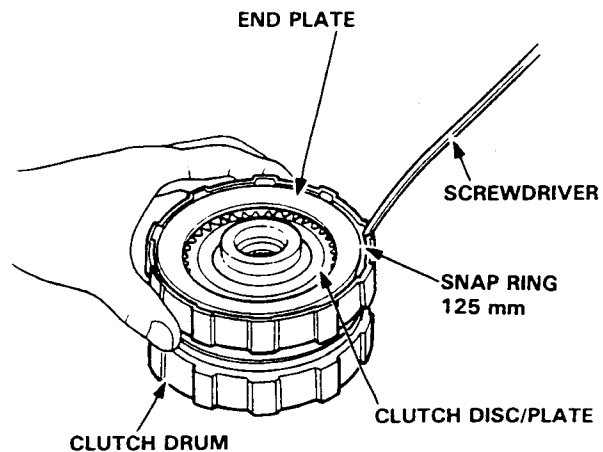

-3. Remove the spring washer.

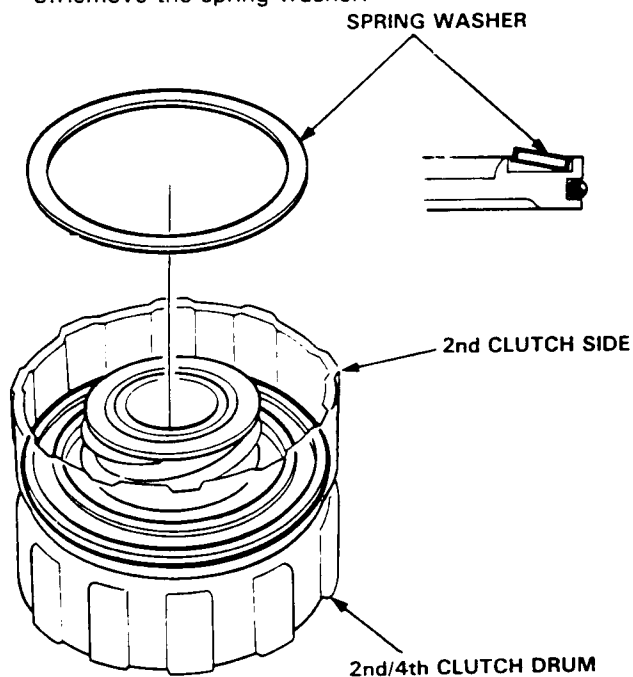

-4. Install the clutch spring compressor as shown and compress the clutch return spring.

**CAUTION:** If either end of the compressor attachment is set over an area of the retainer which is unsupported by the spring, the retainer may be damaged.

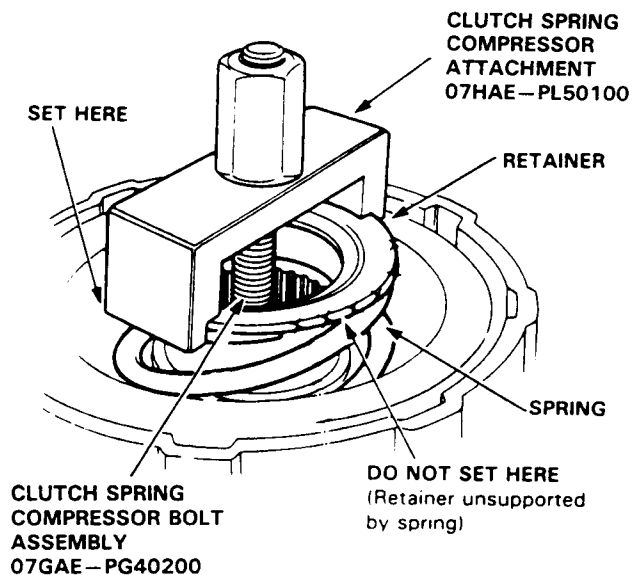

### 3. 3rd Clutch

-1. Remove the snap ring.

-2. Remove the end plate, clutch discs and plates.

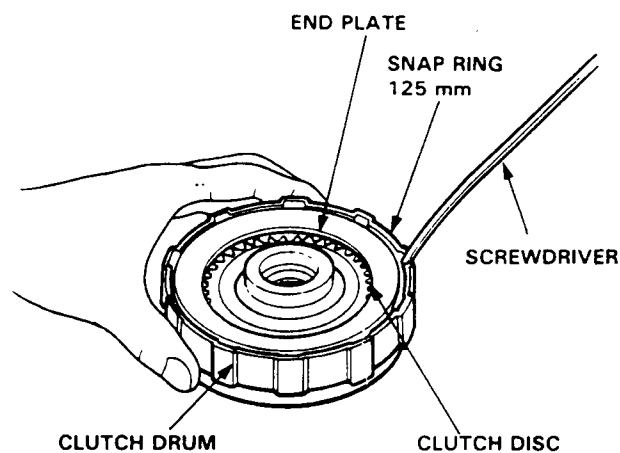

-3. Install the clutch spring compressor as shown and compress the clutch return spring.

**CAUTION:** If either end of the compressor attachment is set over an area of the retainer which is unsupported by the spring, the retainer may be damaged.

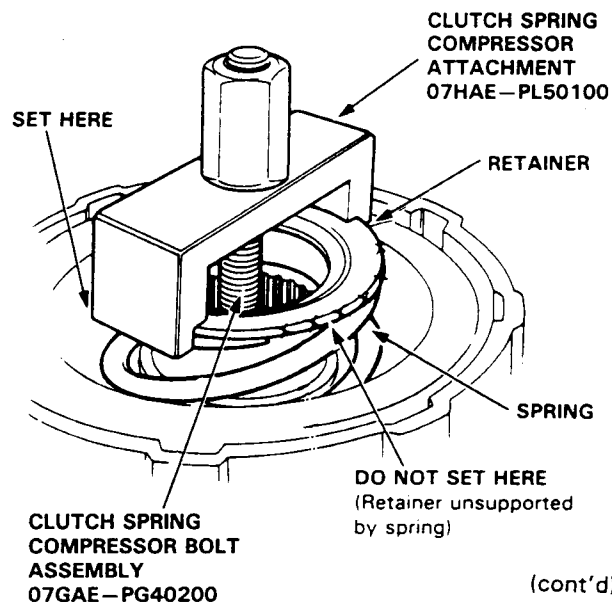

(cont'd)



# Clutch

## Disassembly (cont'd)

### 4. 4th Clutch

- 1. Remove the snap ring.
- 2. Remove the end plate, clutch discs and plates.

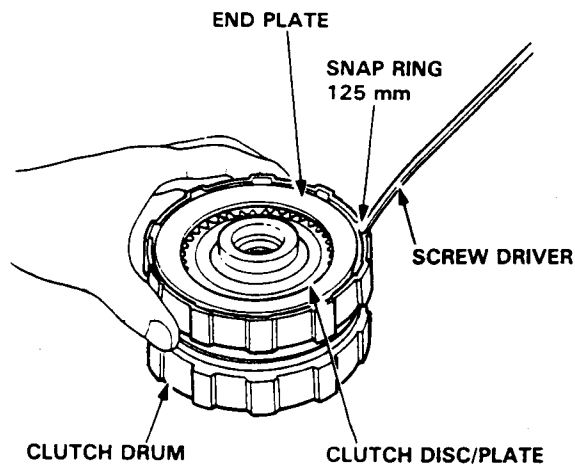

- 3. Install the clutch spring compressor as shown and compress the clutch return spring.

**CAUTION:** If either end of the compressor attachment is set over and area of the retainer which is unsupported by the spring, the retainer may be damaged.

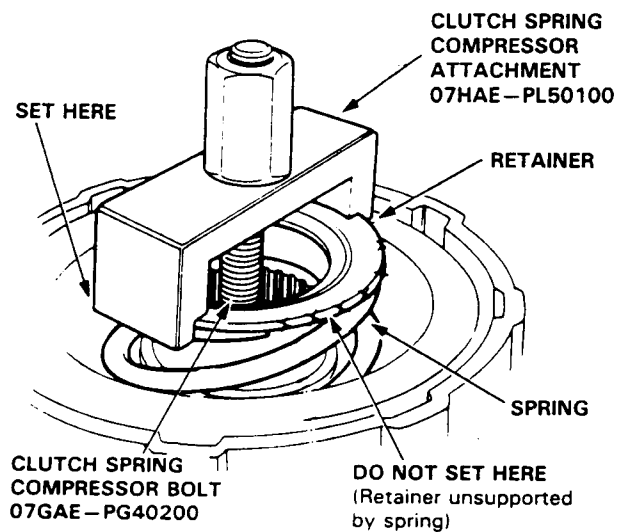

### 5. 1st and 3rd Clutch

- 1. Assemble the spring compressor on the clutch drum.

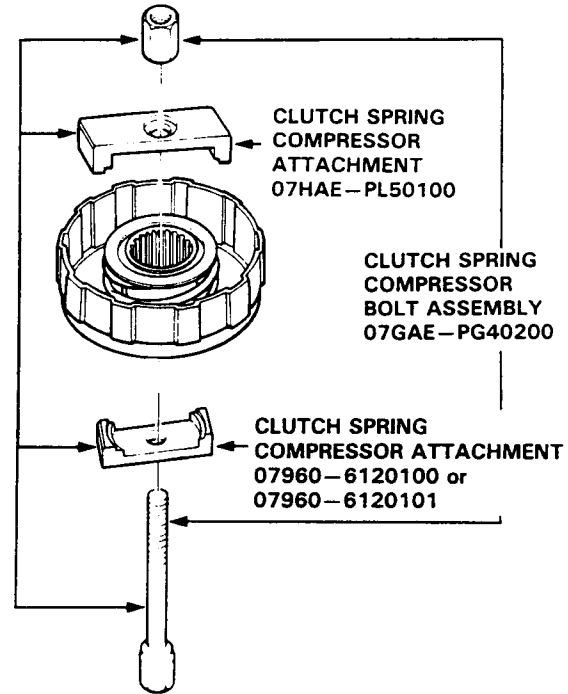

- 2. Compress the clutch return spring.

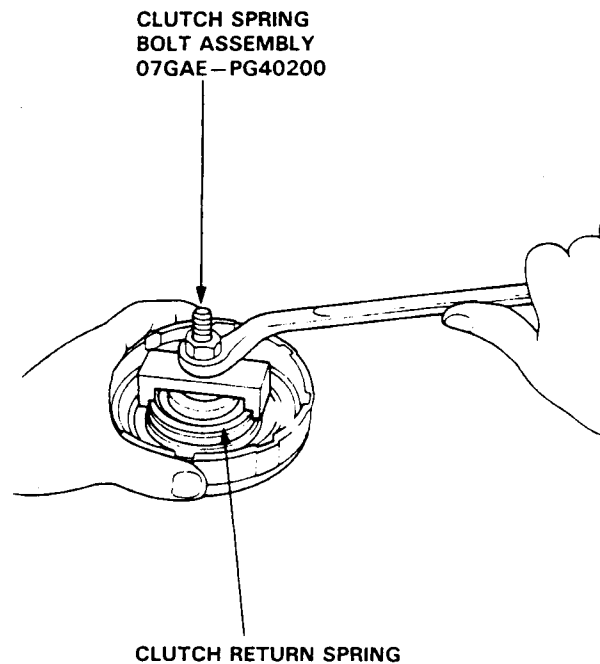

## 6. 2nd/4th Clutch

- 1. Assemble the spring compressor on the clutch drum.

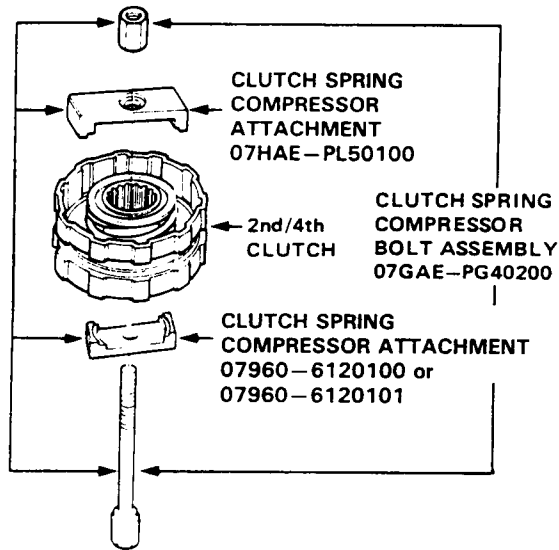

- 2. Compress the clutch return spring.

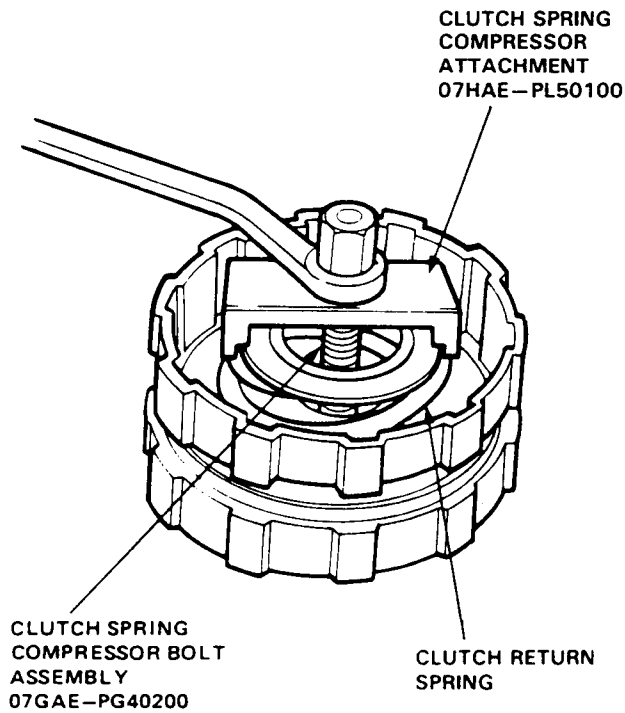

NOTE: Steps 7 and 8 are for all clutches.

- 7. Remove the snap ring. Then remove the clutch spring compressor, spring retainer and spring.

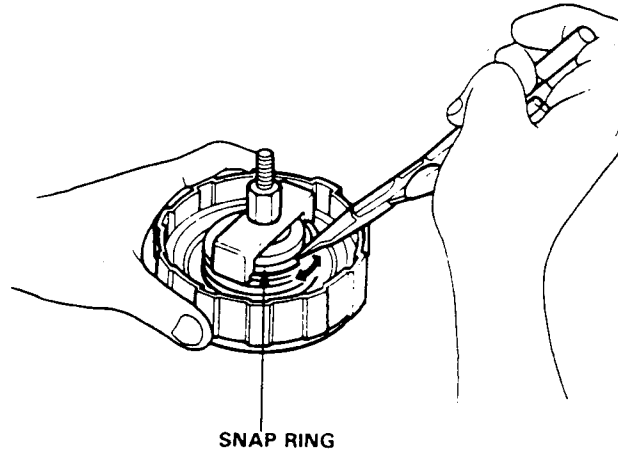

- 8. Wrap a shop rag around the clutch drum and apply air pressure to the oil passage to remove the piston. Place a finger tip on the other end while applying air pressure.

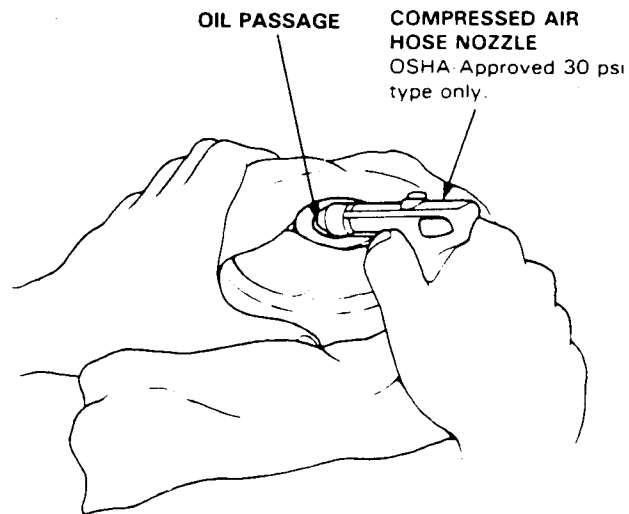

# Clutch

## Disassembly/Inspection

### 1st Clutch

NOTE: Spring washer can be removed from 1st clutch and spring washer can be removed from the 2nd clutch.

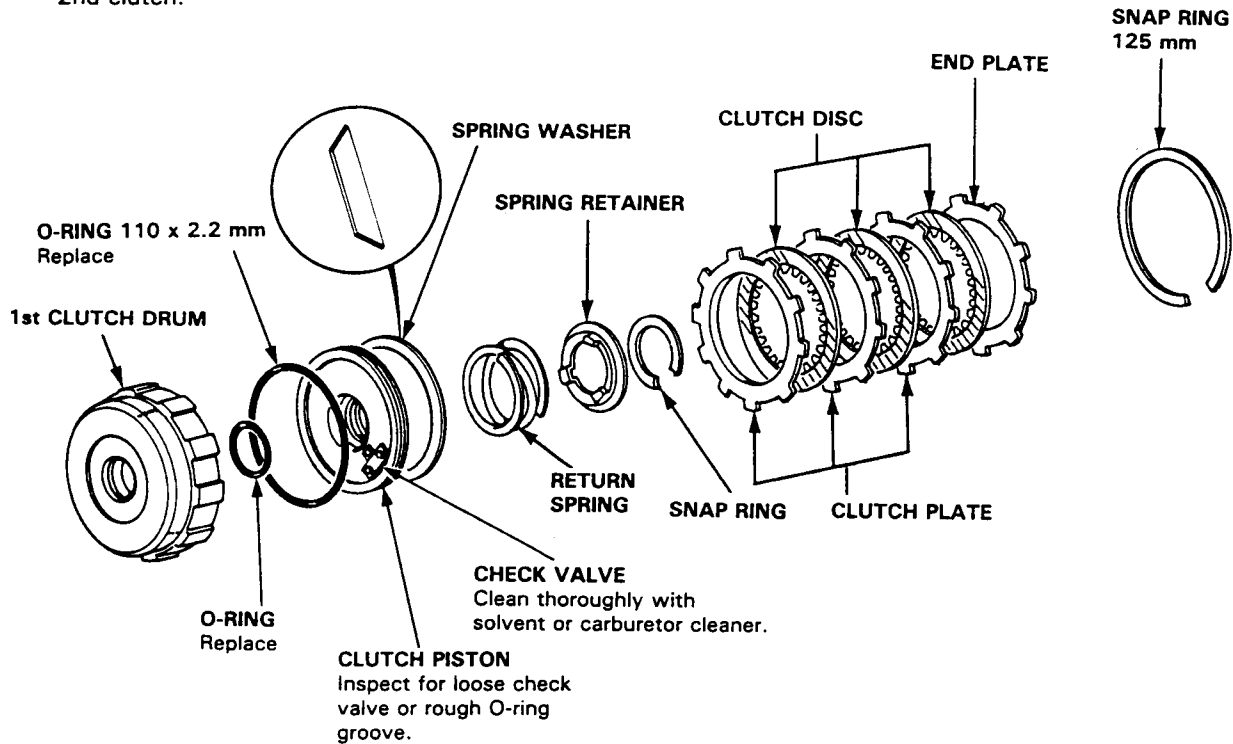

### 3rd Clutch

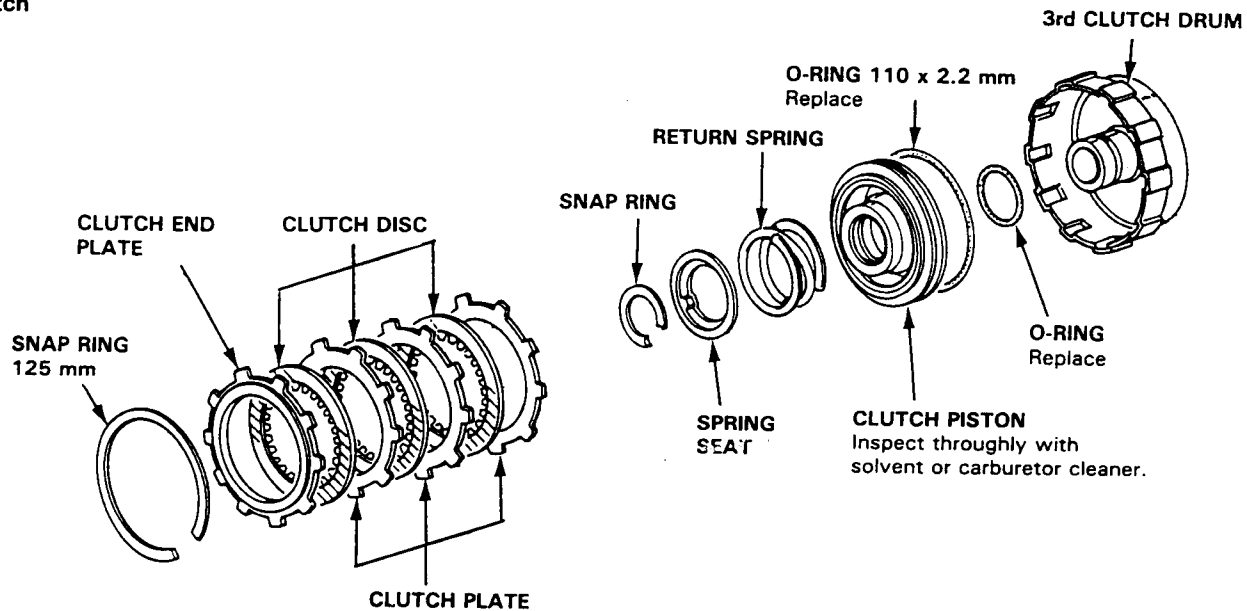

## 2nd/4th Clutch

NOTE: The 2nd clutch spring washer faces the opposite direction of the 3rd and 4th clutch spring washers.

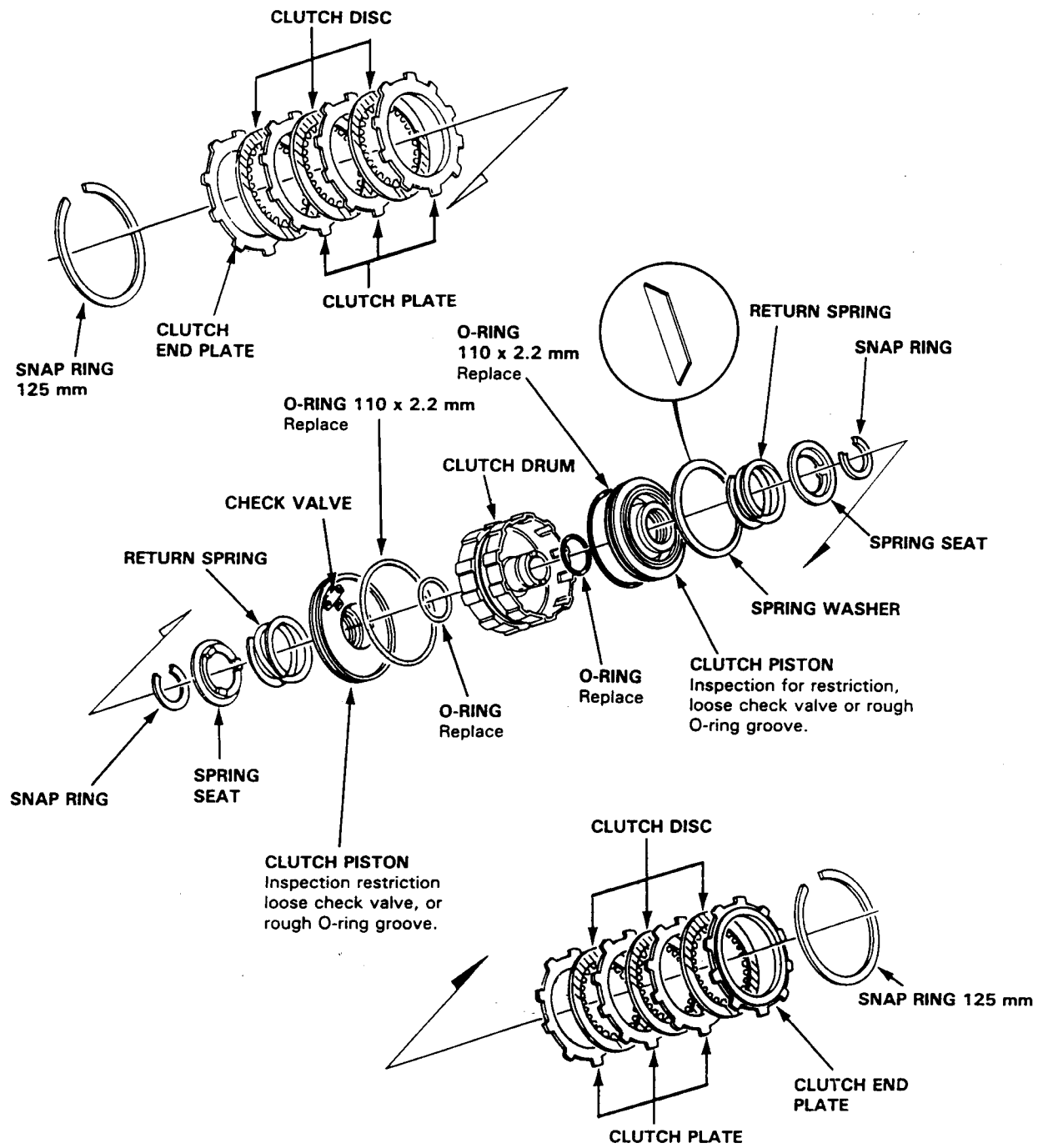

# Clutch

## Reassembly

### NOTE:

- Clean all parts thoroughly in solvent, and dry with compressed air. Blow out all passages.
- Lubricate all parts with ATF before reassembly.

### 1. 1st Clutch

- 1. Install new O-ring on the clutch piston.

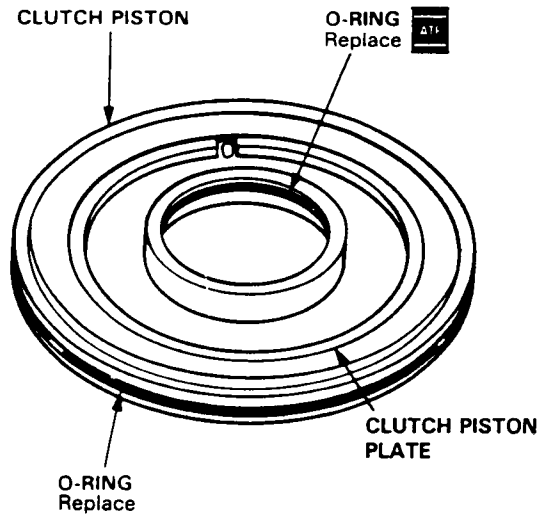

- 2. Install the piston in the clutch drum. Apply pressure and rotate to ensure proper seating.

NOTE: Lubricate the piston O-ring with ATF before installing.

CAUTION: Do not pinch O-ring by forcing piston installation.

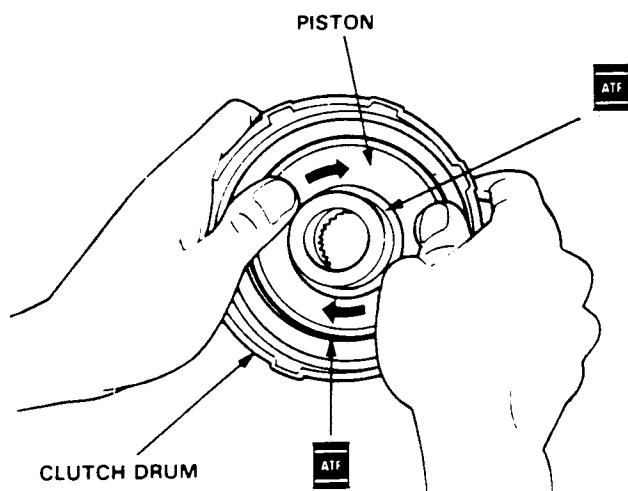

- 3. Install the spring washer.

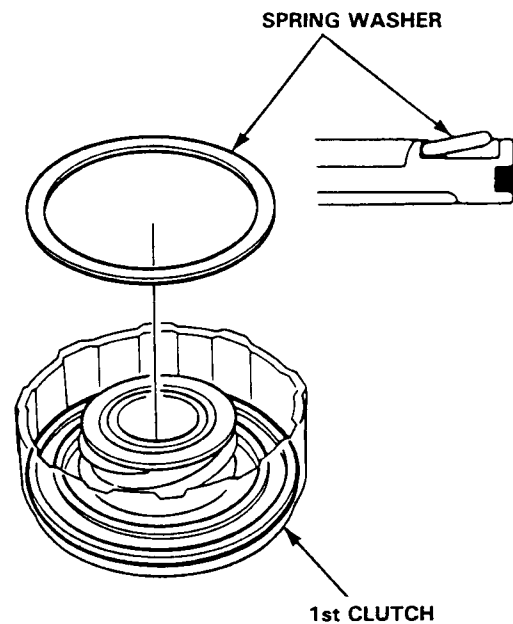

- 4. Install the return spring and retainer.

- 5. Position the snap ring on the spring retainer.

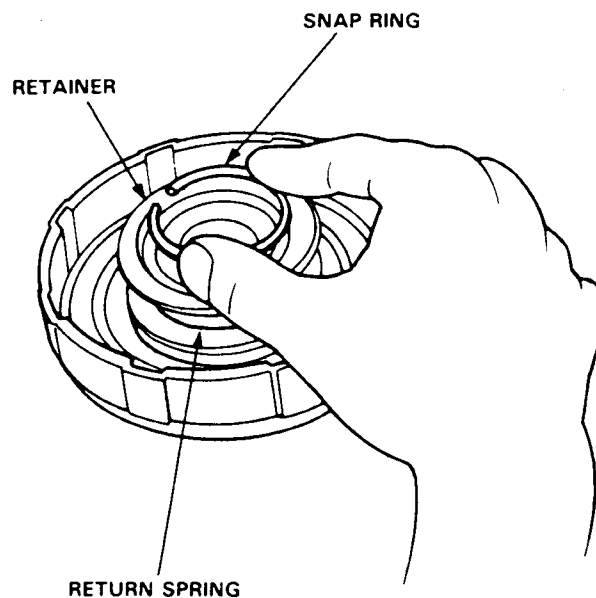

## 2. 2nd Clutch

- 1. Install new O-ring on the clutch piston.

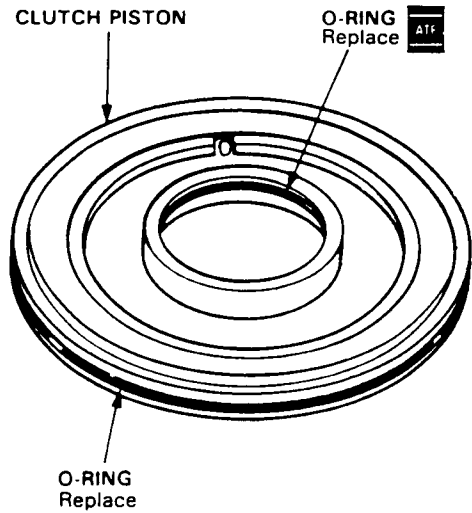

- 2. Install the piston in the clutch drum. Apply pressure and rotate to ensure proper seating.

NOTE: Lubricate the piston O-ring with ATF before installing.

CAUTION: Do not pinch O-ring by forcing piston installation.

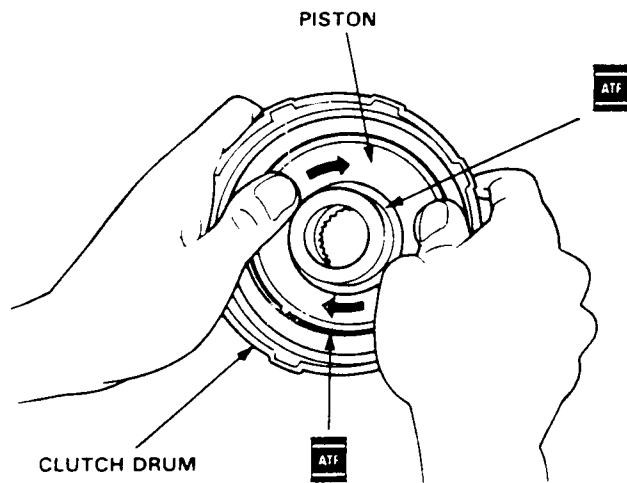

- 3. Install the spring washer.

NOTE: Note the spring washer direction.

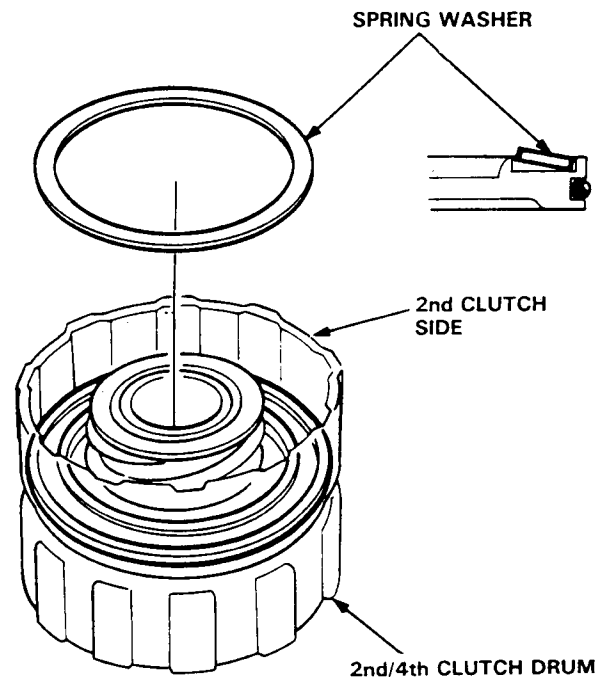

- 4. Install the return spring and retainer.
- 5. Position the snap ring on the spring retainer.

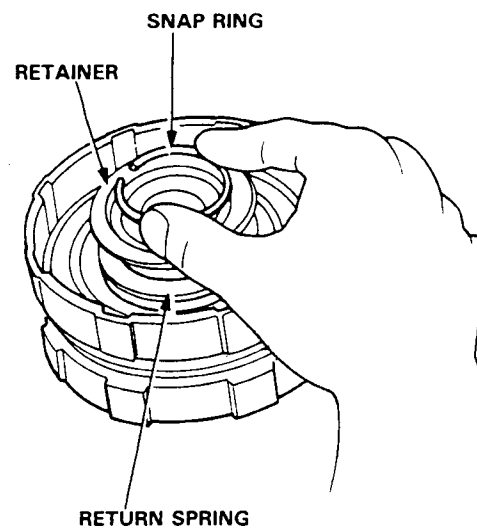

(cont'd)

# Clutch

## Reassembly (cont'd)

### 3. 3rd Clutch

- 1. Install a new O-ring on the clutch piston. Be sure that the disc spring is securely staked.

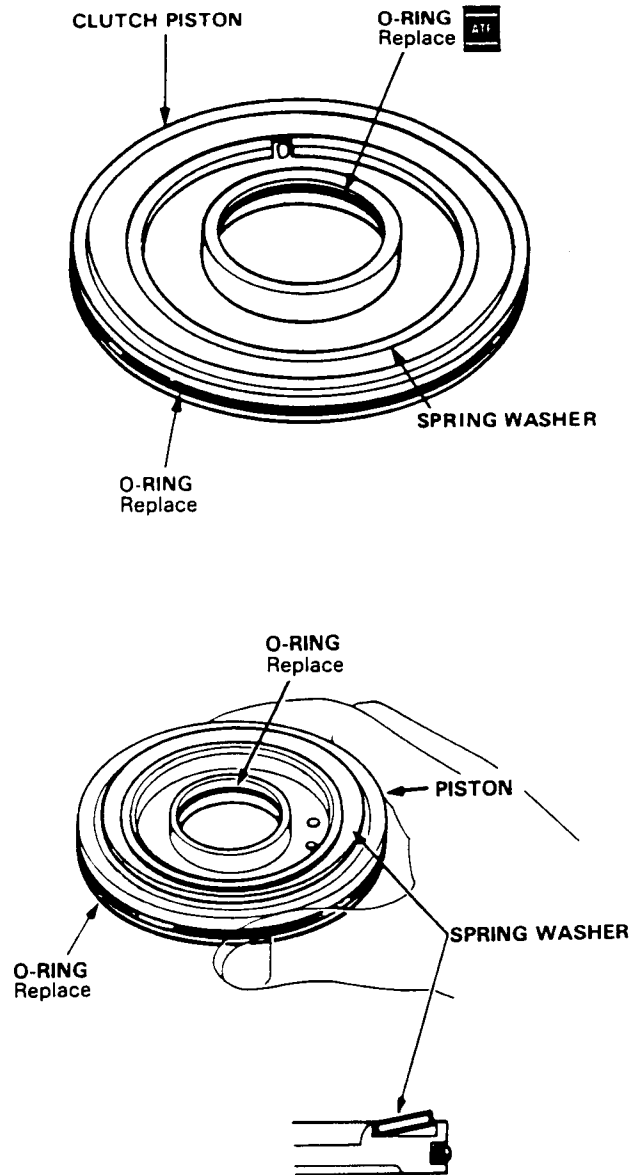

- 2. Install the piston in the clutch drum. Apply pressure and rotate to ensure proper seating.

NOTE: Lubricate the piston O-ring with ATF before installing.

CAUTION: Do not pinch O-ring by forcing piston installation.

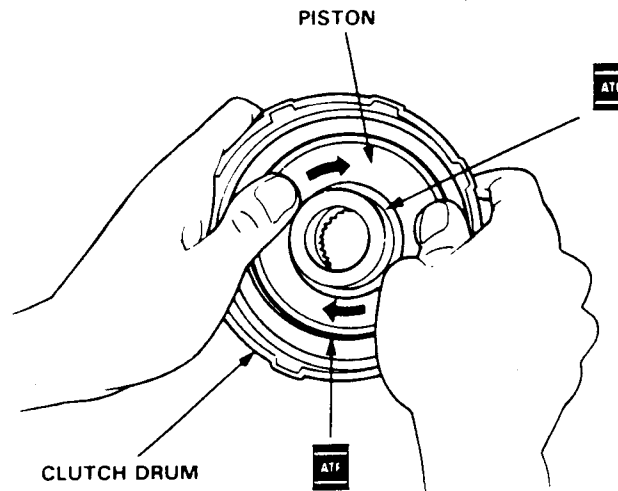

- 3. Install the return spring and retainer.
- 4. Position the snap ring on the spring retainer.

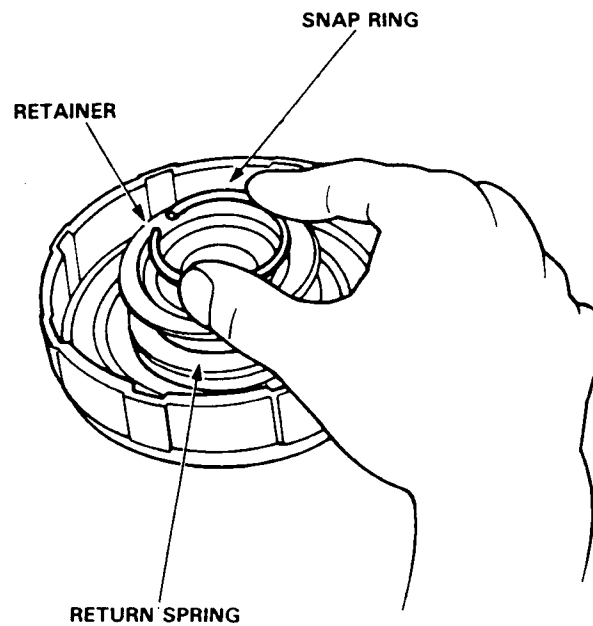

#### 4. 4th Clutch

- 1. Install a new O-ring on the clutch piston.  
Be sure that the disc spring is securely staked.

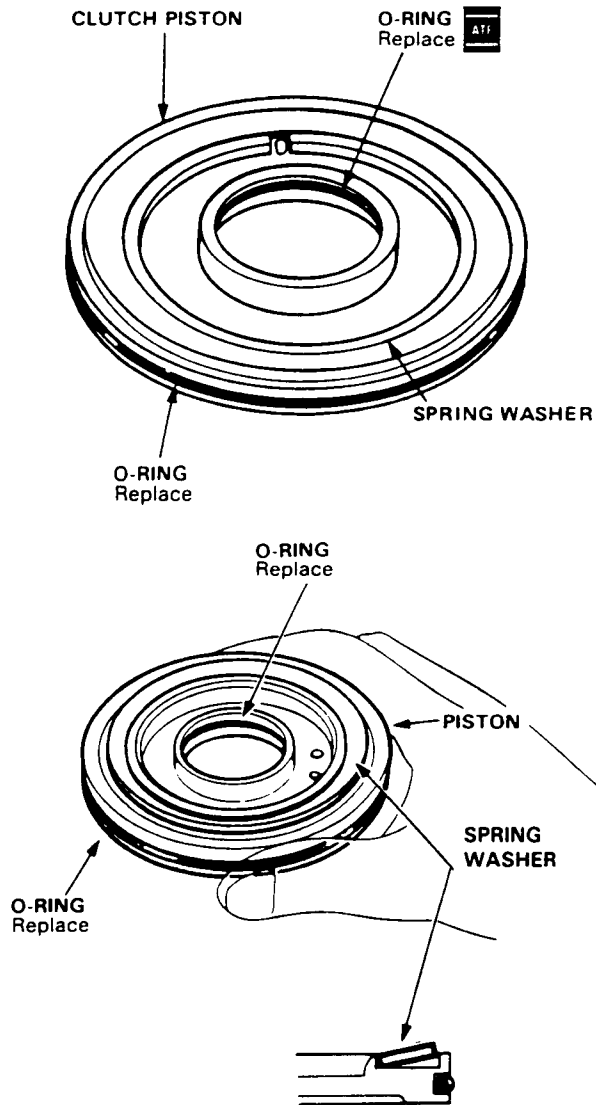

- 2. Install the piston in the clutch drum. Apply pressure and rotate to ensure proper seating.

NOTE: Lubricate the piston O-ring with ATF before installing.

CAUTION: Do not pinch O-ring by forcing piston installation.

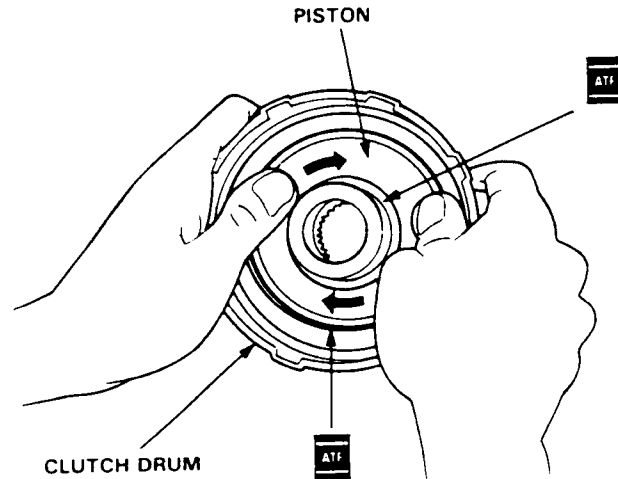

- 3. Install the return spring and retainer.
- 4. Position the snap ring on the spring retainer.

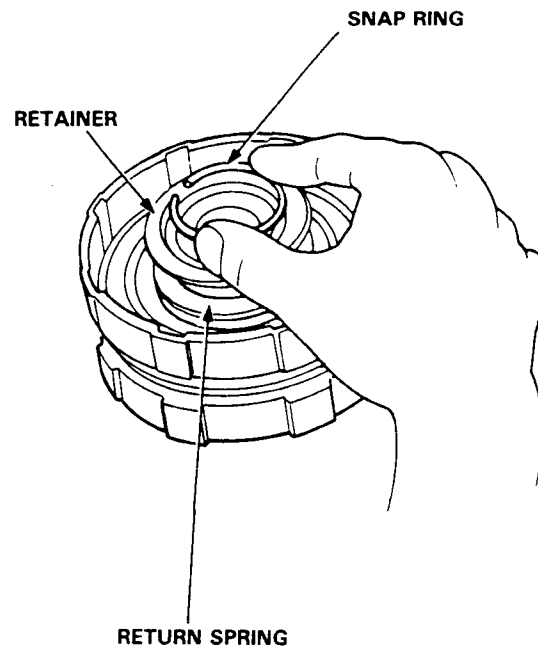

(cont'd)



# Clutch

## Reassembly (cont'd)

NOTE: Step 5 is for all clutches.

5. Install the spring compressor on the clutch drum and compress the clutch return spring.

**CAUTION:** If either end of the compressor attachment is set over an area of the retainer which is unsupported by the spring, the retainer may be damaged.

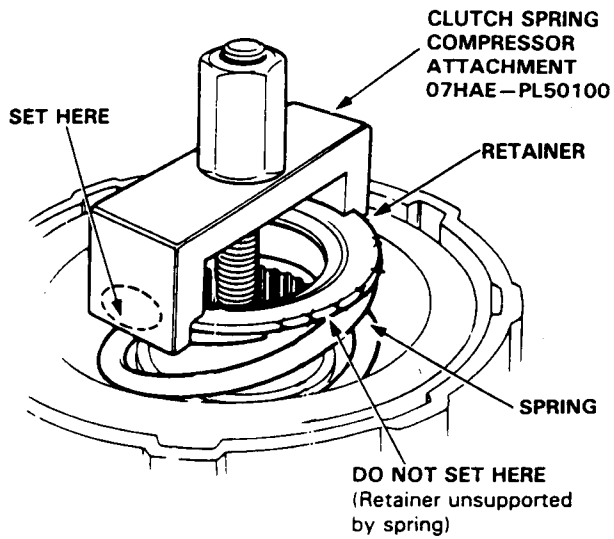

### 6. 1st and 3rd Clutch

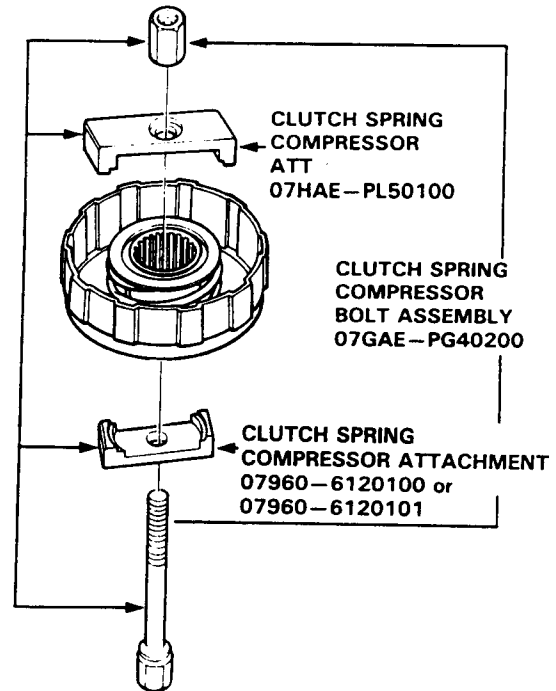

- 1. Compress the clutch return spring.

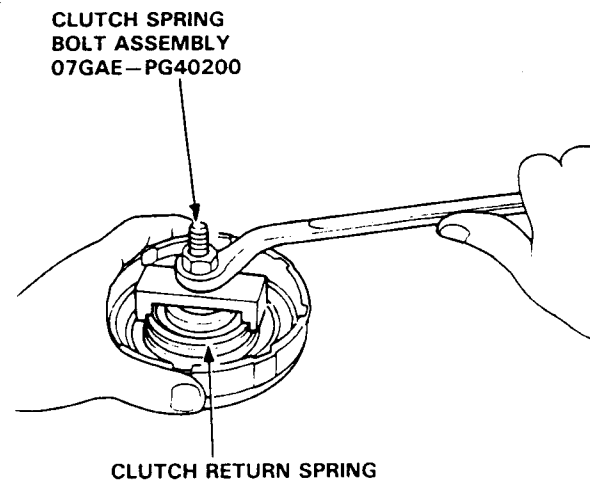

7. 2nd/4th Clutch

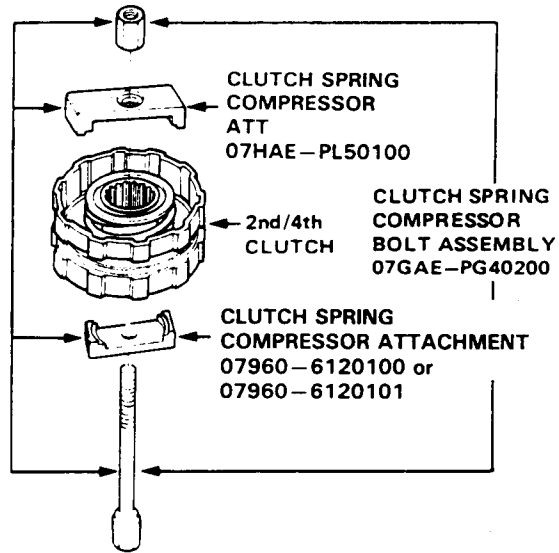

- 1. Compress the clutch return spring.

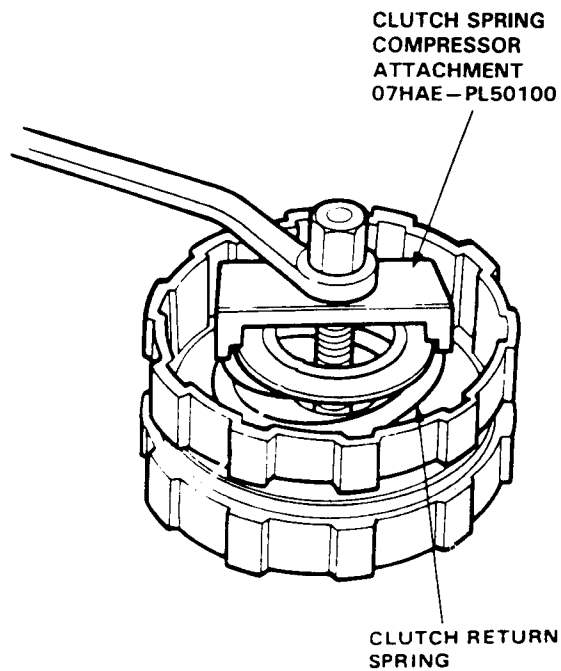

NOTE: Steps 8 thru 15 are for all clutches.

8. Remove the snap ring.
9. Remove the clutch spring compressor, spring retainer and spring.

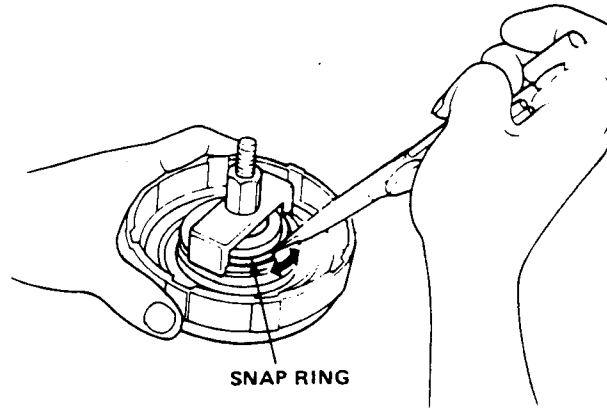

10. Soak the clutch discs thoroughly in automatic transmission fluid for a minimum of 30 minutes.
11. Starting with a clutch plate, alternately install the clutch plates and discs. Install the clutch end plate with flat side toward the disc.

NOTE: Before installing the plates and discs, make sure the inside of the clutch drum is free of dirt or other foreign matter.

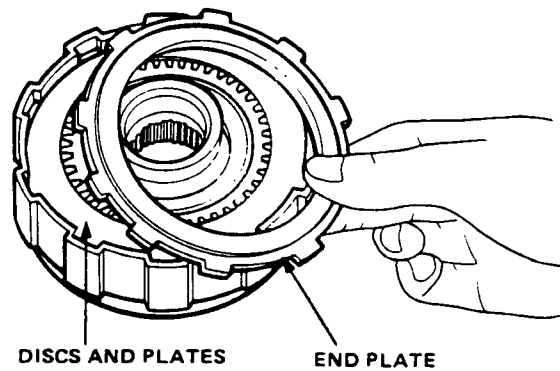

(cont'd)

# Clutch

## Reassembly (cont'd)

12. Install the 125 mm snap ring.

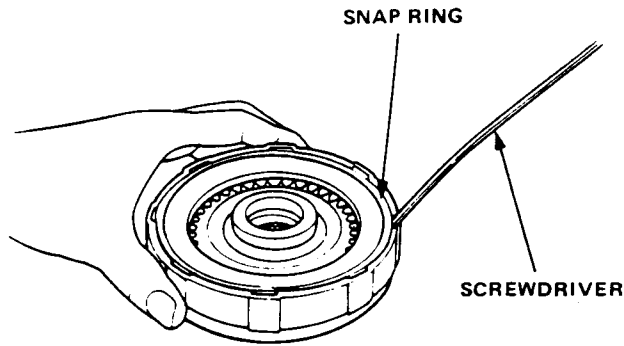

13. Check the clutch engagement by blowing air into the oil passage in the clutch drum hub. Remove the air pressure and check that the clutch releases.

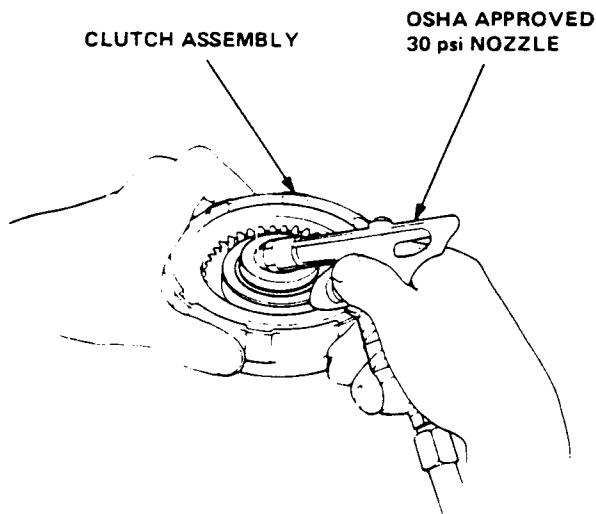

14. Measure the clearance between the clutch end plate and top disc with a dial indicator.

Zero the dial indicator with the clutch end plate lowered and lift it up to the snap ring. Distance where the clutch end plate moves is the clearance between the clutch end plate and top disc.

NOTE: Measure at three locations.

End Plate-to-Top Disc Clearance:

	Service Limit	
LOW	0.65–0.85 mm	(0.026–0.033 in.)
2ND	0.40–0.60 mm	(0.016–0.024 in.)
3RD	0.40–0.60 mm	(0.016–0.024 in.)
4TH	0.40–0.60 mm	(0.016–0.024 in.)

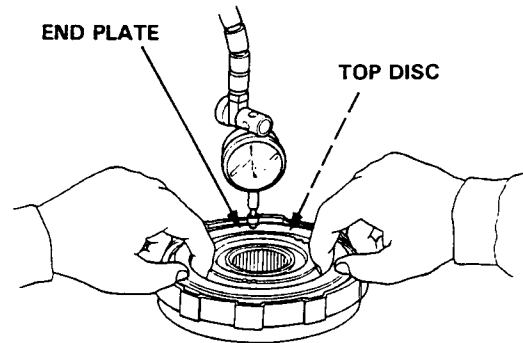

15. If the clearance is not within the service limits, select a new clutch end plate from the following table.

NOTE: If the thickest clutch and plate is installed but the clearance is still over the standard, replace the clutch discs and clutch plates.

P/N	PLATE NO.	THICKNESS
22551–PF4–000	1	2.1 mm (0.082 in.)
22552–PF4–000	2	2.2 mm (0.086 in.)
22553–PF4–000	3	2.3 mm (0.090 in.)
22554–PF4–000	4	2.4 mm (0.094 in.)
22555–PF4–000	5	2.5 mm (0.098 in.)
22556–PF4–000	6	2.6 mm (0.102 in.)
22557–PF4–000	7	2.7 mm (0.106 in.)
22558–PF4–000	8	2.8 mm (0.110 in.)
22559–PF4–000	9	2.9 mm (0.114 in.)
22560–PF4–000	10	3.0 mm (0.118 in.)
22561–PF4–000	11	3.1 mm (0.122 in.)
22562–PF4–000	12	3.2 mm (0.126 in.)
22563–PF4–000	13	3.3 mm (0.130 in.)
22564–PF4–000	14	3.4 mm (0.134 in.)

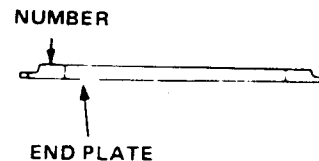

# Bearings and Seals

## Replacement

### Torque converter housing

1. Remove the differential assembly.
2. Remove the countershaft bearing.
3. Replace the oil guide plate.

Commercially Available  
3/8 x 16 Slide Hammer

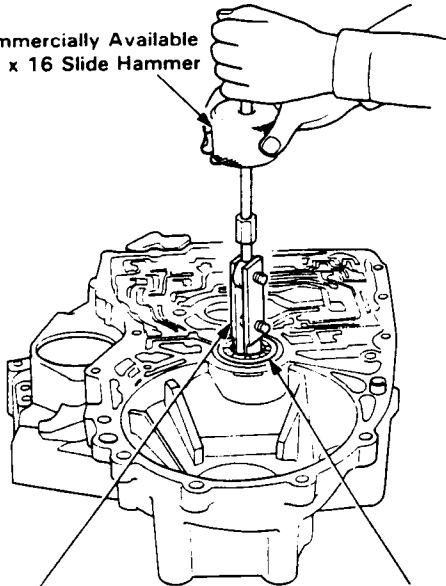

ADJUSTABLE BEARING TULLER  
(25-40 mm)  
07736-A01000A

COUNTERSHAFT  
NEEDLE BEARING  
Replace with new  
bearing if removed.

4. Drive in the new bearing until it bottoms in the housing.

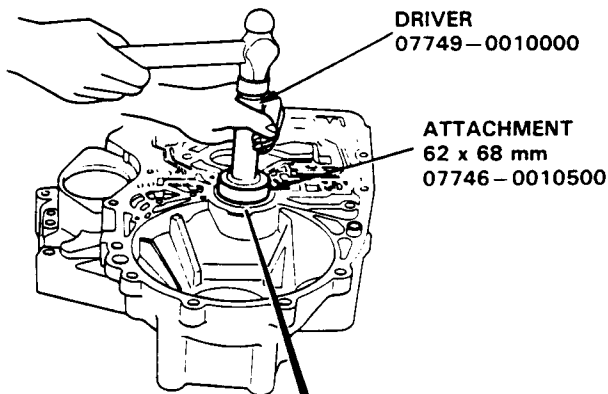

DRIVER  
07749-0010000

ATTACHMENT  
62 x 68 mm  
07746-0010500

HOUSING

BEARING

OIL GUIDE PLATE  
Replace

5. Drive out the mainshaft bearing and oil seal.

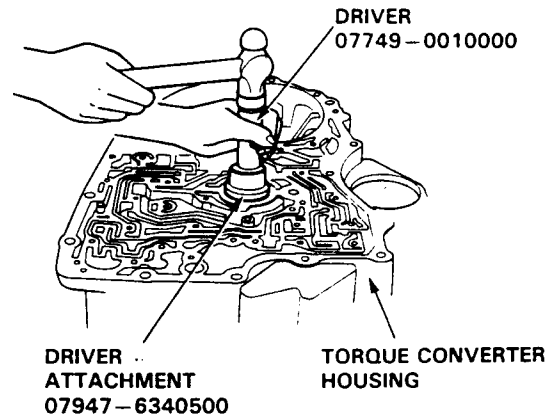

DRIVER  
07749-0010000

DRIVER  
ATTACHMENT  
07947-6340500

TORQUE CONVERTER  
HOUSING

6. Drive in the new mainshaft bearing until it bottoms in housing.

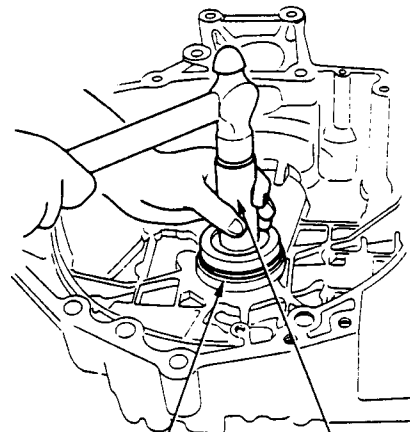

ATTACHMENT  
62 x 68 mm  
07746-0010500

DRIVER  
07749-0010000

7. Install the oil seal flush with the housing.

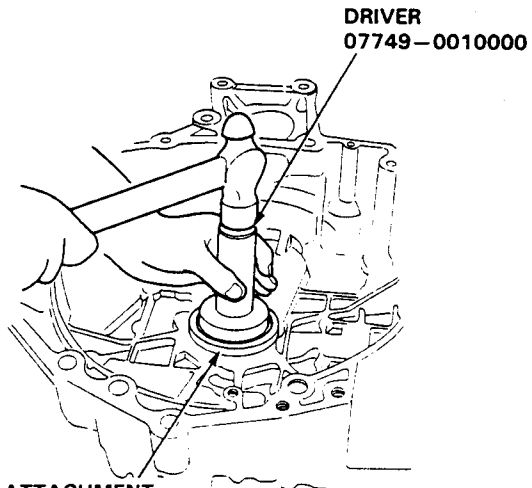

DRIVER  
07749-0010000

DRIVER ATTACHMENT  
07947-6340201

(cont'd)

# Bearing and Seals

## Replacement (cont'd)

### Transmission housing

8. To remove the mainshaft bearing from the transmission housing, expand the snap ring with snap ring pliers, then push the bearing out by hand.

NOTE: Do not remove the snap ring unless it's necessary to clean the groove in the housing.

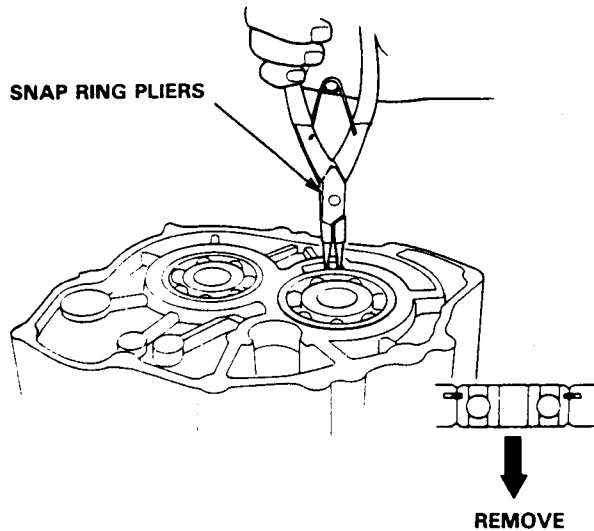

9. Expand the snap ring with snap ring pliers, insert the new bearing part-way into it, then release the pliers. Push the bearing down into the transmission until the ring snaps in place around it.

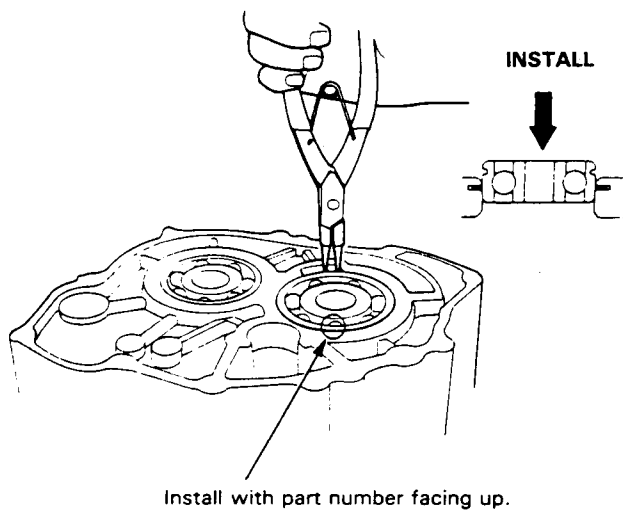

10. Make sure the snap ring is seated in the bearing and housing grooves.

11. To remove the countershaft bearing from the transmission housing, expand the snap ring with snap ring pliers, then push the bearing out by hand.

NOTE: Do not remove the snap ring unless it's necessary to clean the grooves in the housing.

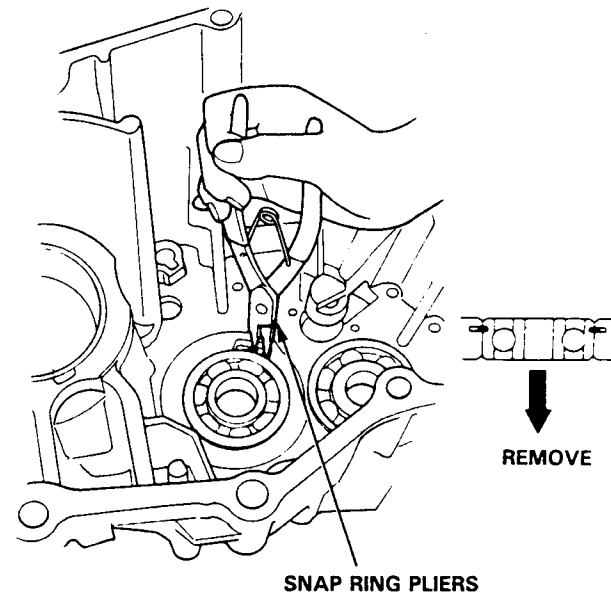

12. Expand the snap ring with snap ring pliers, insert the new bearing part-way into it, then release the pliers. Push the bearing down into the transmission until the ring snaps in place around it.

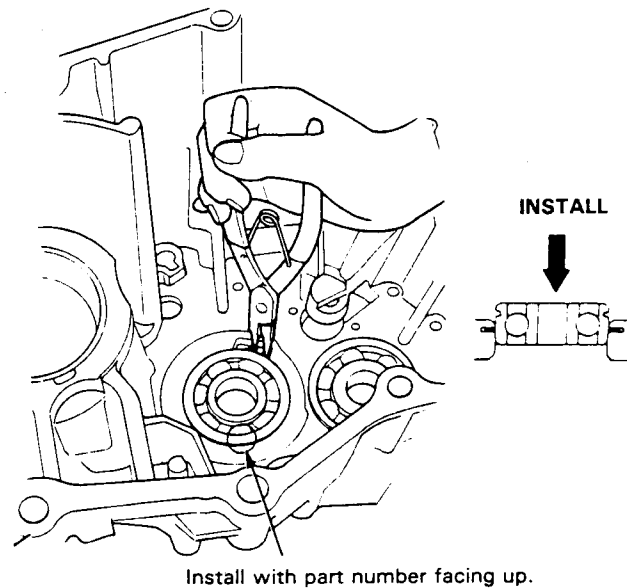

13. Make sure the snap ring is seated in the bearing and housing grooves.

# Reverse Idler Gear

## Installation

1. Install the reverse idler gear from the inner side of the housing.

NOTE: Be sure to install the reverse idler gear with the chamfered side toward torque converter housing.

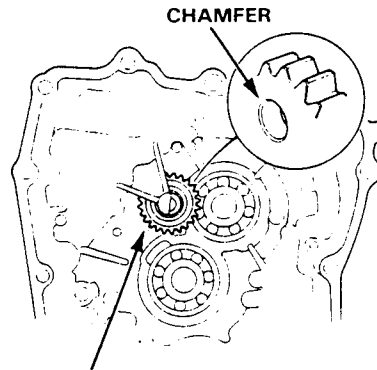

REVERSE IDLER GEAR

2. Install the reverse idler gear shaft, spring, new washer and holder bolt on the reverse idler gear shaft holder.
3. Set the spring and steel ball in the idler gear shaft hole, then install the needle bearing.
4. Install the idler shaft holder in the transmission housing with care not to drop the needle bearing.

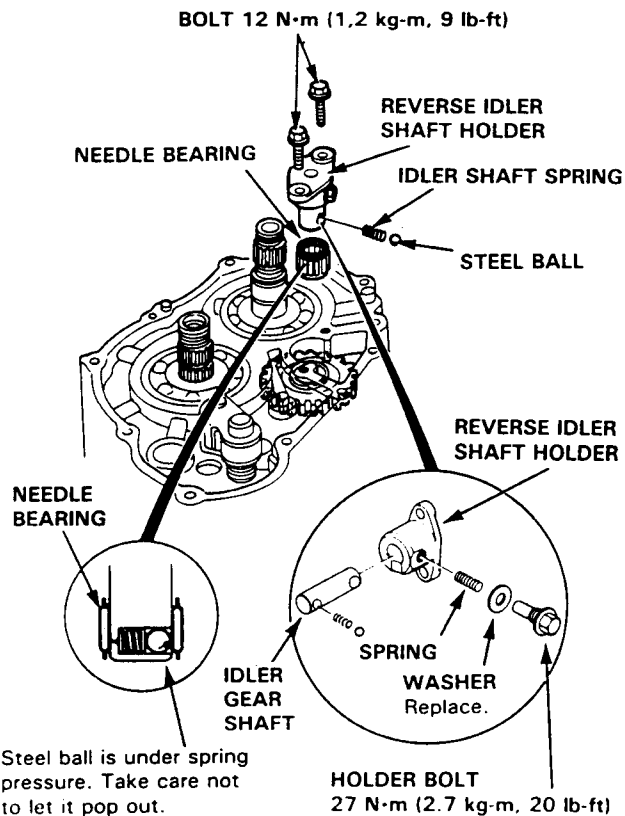

# End Cover

## Disassembly/Inspection

**CAUTION:** Remove and install parts carefully to avoid damaging them.

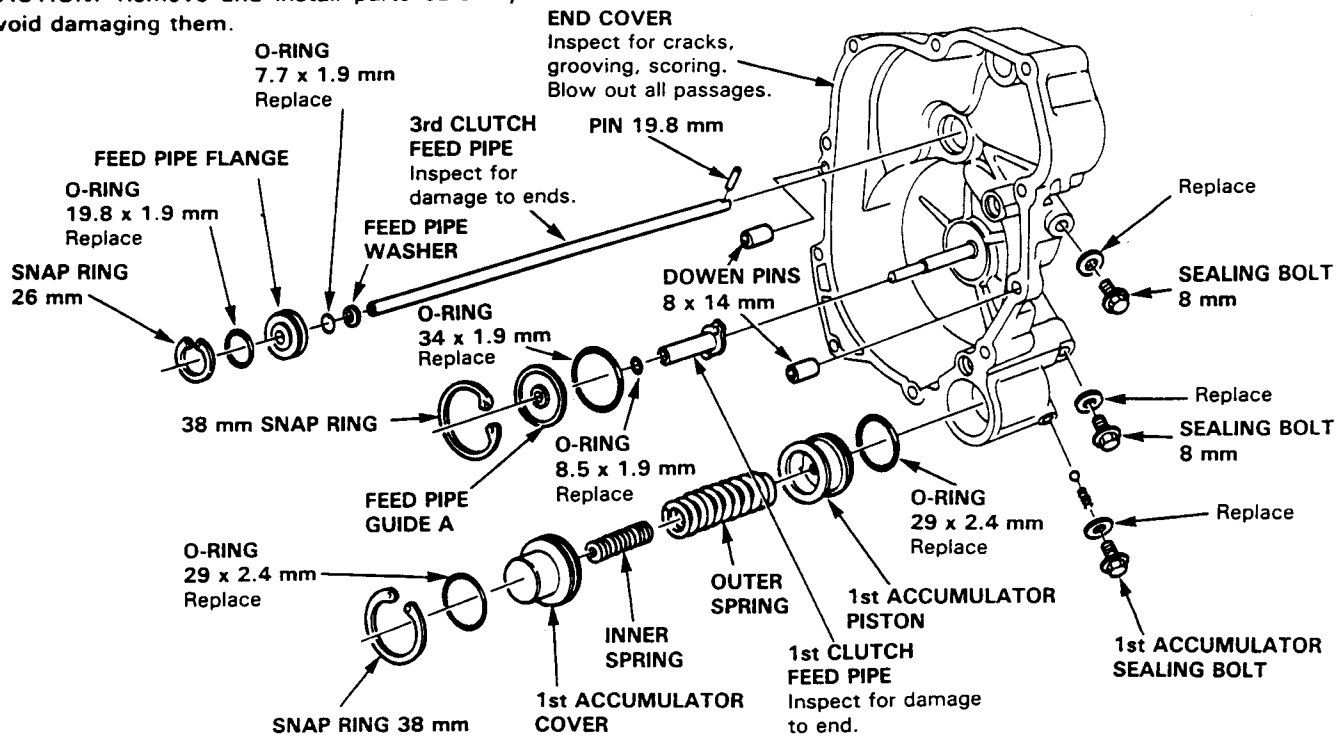

## Reassembly

1. Seat a new O-ring in the groove of the 1st accumulator, and slide the accumulator piston into the right side transmission cover. Install the outer spring, inner spring, another new O-ring and the accumulator cover, in that order.
2. Install 38 mm snap ring.

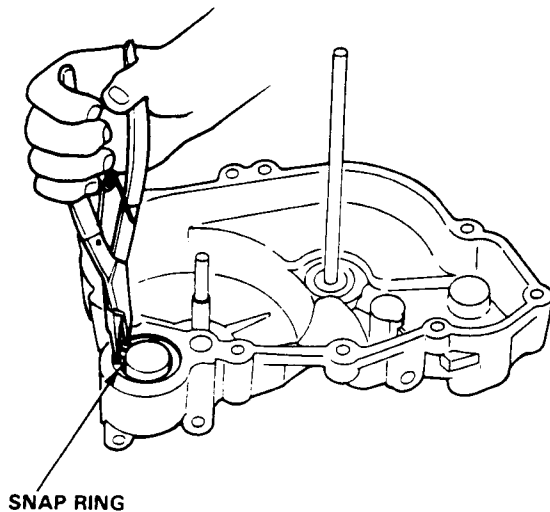

3. With feed pipes assembled, align lugs on the collars with slot in end cover.
4. Install the snap ring.
5. Install the feed pipes in the end cover, aligning the lugs of the 1st clutch feed pipe with the grooves of the end cover.
6. Install the snap ring.

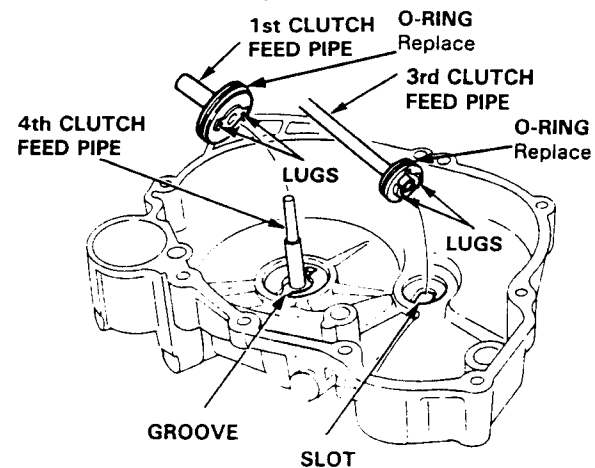

# Control Shaft

## Installation

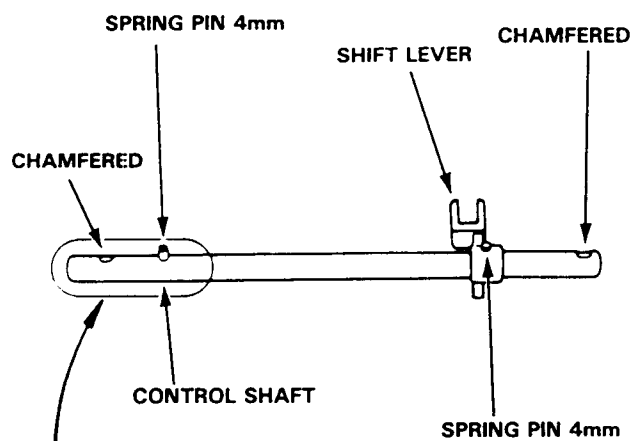

Drive the 4 mm spring pin in from the side with the chamfered hole, to a depth of 1mm from the opposite side.

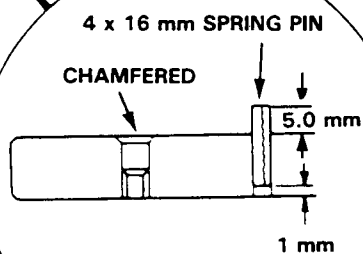

# Transmission

## Reassembly

NOTE: Lubricate all parts with ATF during reassembly.

1. Install the differential assembly. If the torque converter housing, transmission housing and/or differential side bearings were replaced, the differential taper roller bearing preload must be checked.
2. Assemble the manual valve lever on the control shaft, then install in the torque converter housing as shown.

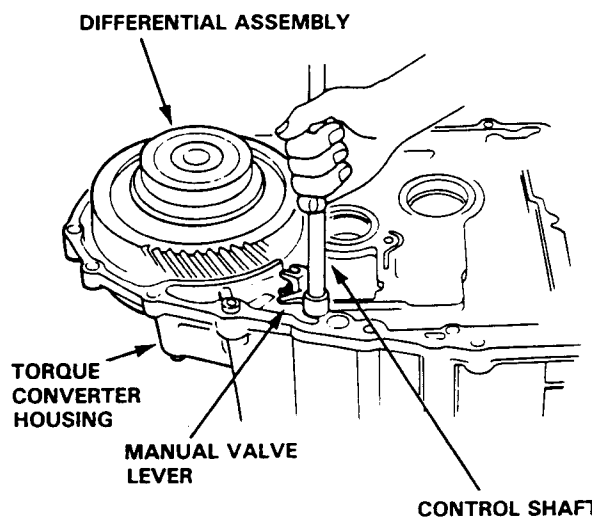

3. Install the control lever and new lock plate on the other end of the shaft. Tighten the bolt to the torque shown, then bend the tab over against the bolt head.

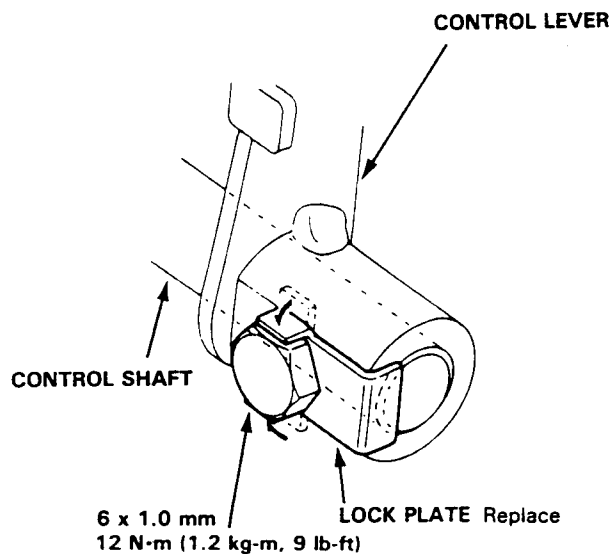

(cont'd)



# Transmission

## Reassembly (cont'd)

4. Install the main separator plate and dowel pin on the torque converter housing.

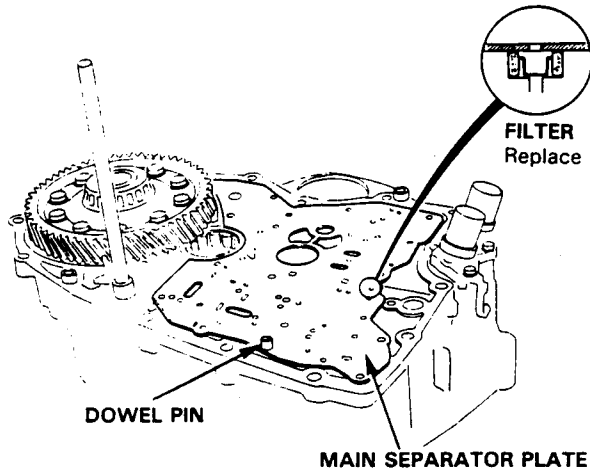

5. Install the oil pump gears and shaft on the torque converter housing.

NOTE: Install the oil pump driven gear with its chamfered side facing down.

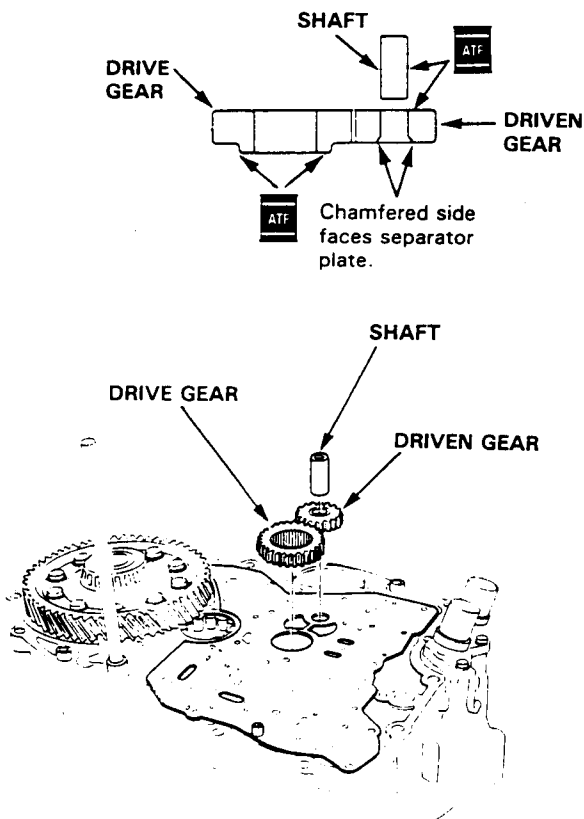

6. Install the main valve body on the torque converter housing and loosely tighten with 5 bolts in the sequence shown.

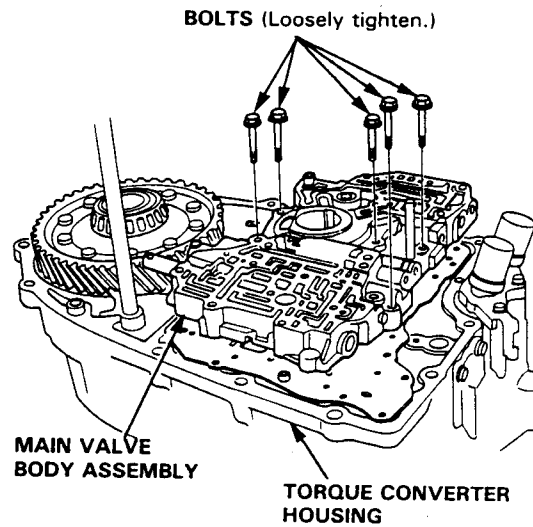

7. Securely tighten the 5 bolts in the sequence shown in step 6.

8. Make sure the pump drive gear rotates smoothly in the normal operating direction and the pump shaft moves smoothly in the axial and normal operating directions.

**CAUTION:** If the pump gear and pump shaft do not move freely, loosen the valve body bolts, realign the shaft, and then retighten to the specified torque.

Failure to align the pump shaft correctly will result in seized pump gear or pump shaft.

9. Install the 4 steel balls in main valve body oil passages.

10. Install the filter in main valve body.

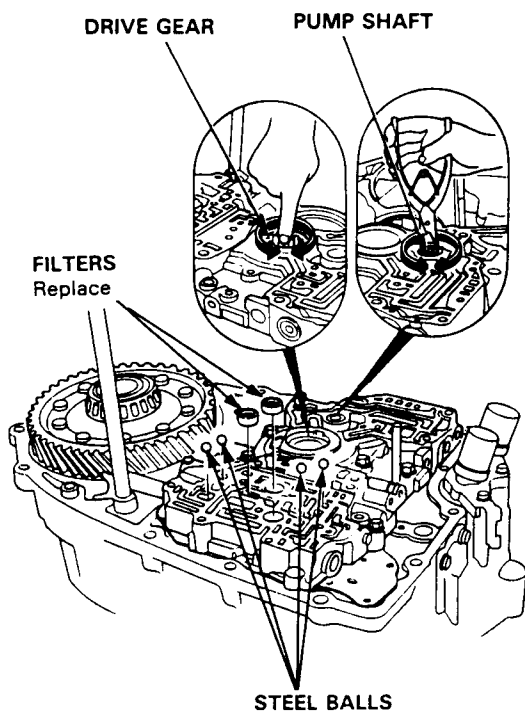

11. Install the stator shaft arm, stop pin and dowel pins.

**TORQUE: 12 N·m (1.2 kg-m, 9 lb-ft)**

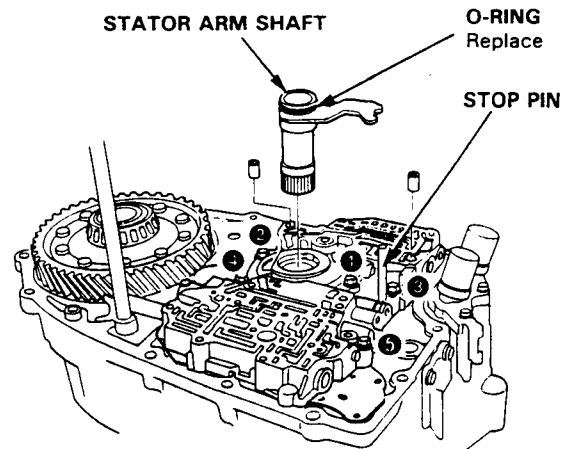

12. Install the regulator valve body assembly on the main valve body assembly.

**12 N·m (1.2 kg-m, 9 lb-ft)**

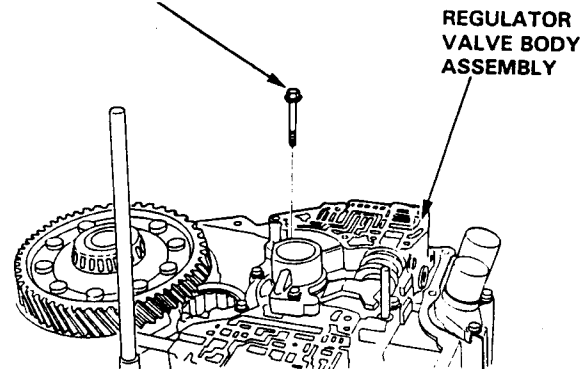

(cont'd)

# Transmission

## Reassembly (cont'd)

13. Install the lock-up timing valve separator plate with 2 dowel pins and lock-up timing valve body assembly with 7 bolts as shown.

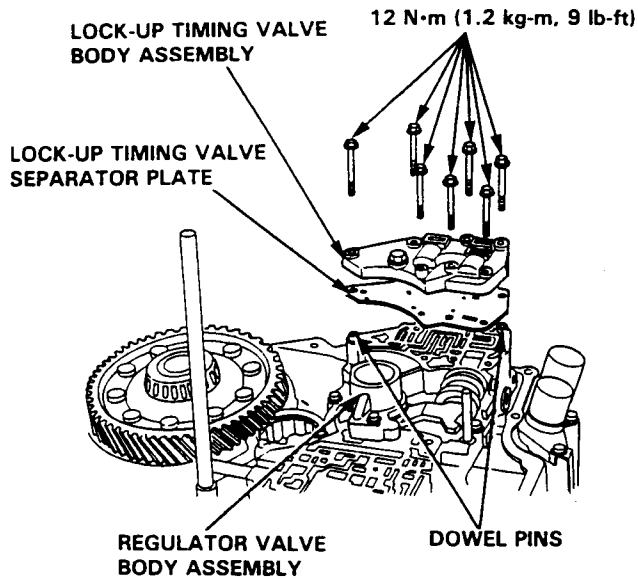

14. Install the secondary separator plate and secondary valve body assembly on the main valve body assembly.

15. Install the secondary filter, ball spring and steel balls in the secondary valve body assembly.

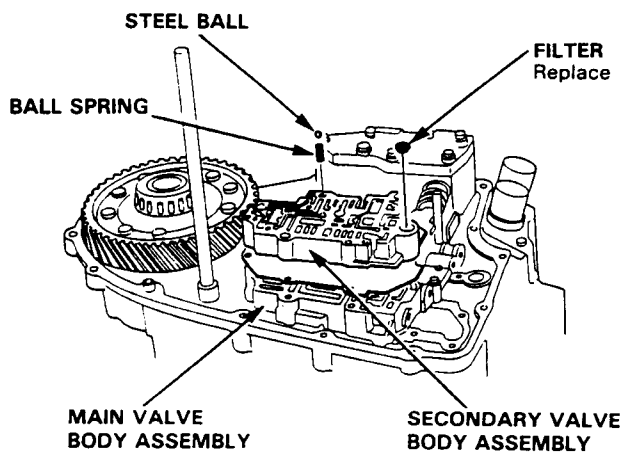

16. Install the separator plate and dowel pins, then install the throttle control shaft.

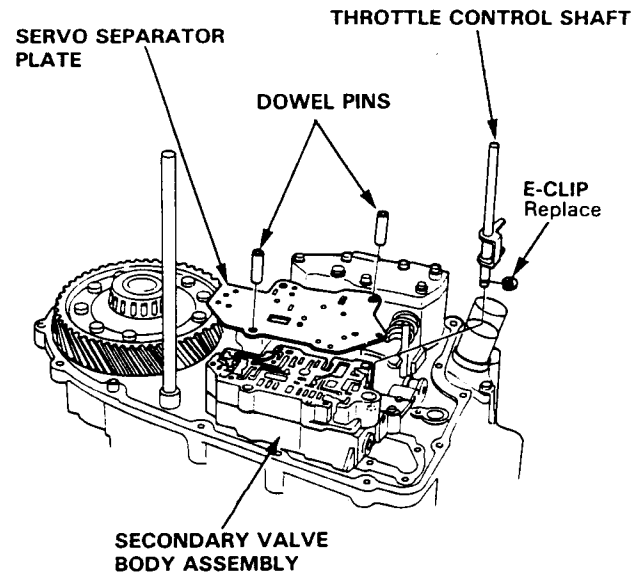

17. Install the shift fork shaft, servo return spring, 3rd, 4th accumulator piston, filter screen and magnet on the servo valve body assembly.

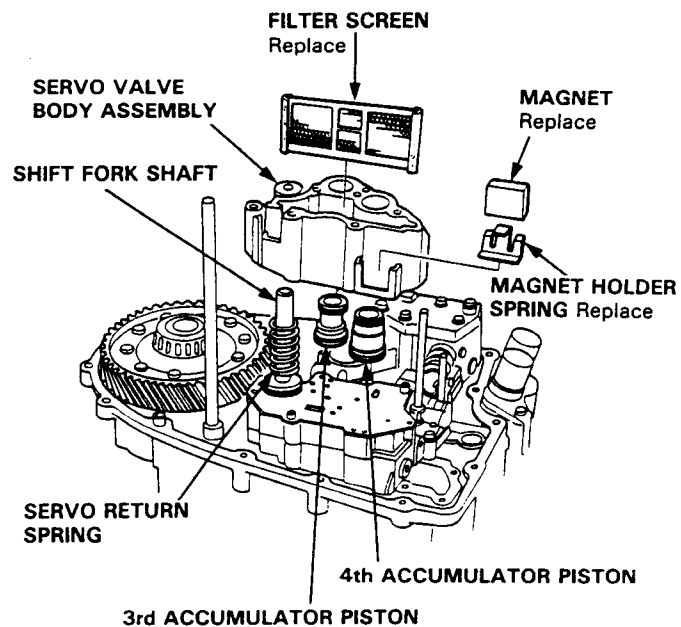

18. Install the servo valve body assembly and tighten the fore bolts.

**NOTE:**

- Install the stopper cap as shown.
- Do not forget to install the bolts in the oil strainer chamber.

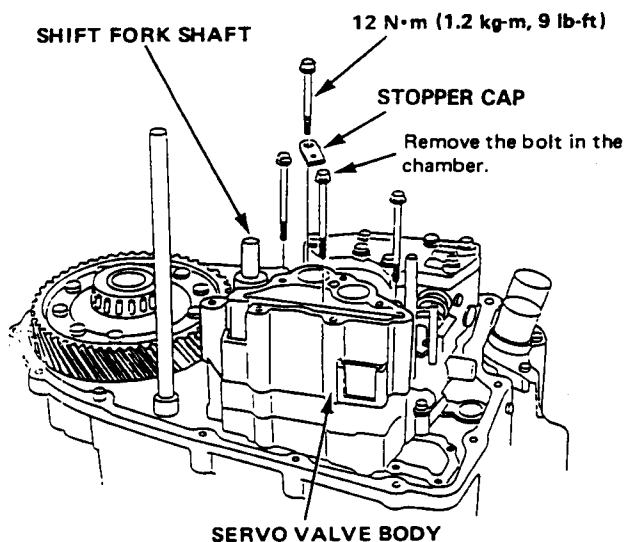

19. Install the accumulator springs.
20. Install the accumulator cover, and torque the bolts to 12 N·m (1.2 kg-m, 9 lb-ft) in a crisscross pattern.

**CAUTION:** To prevent stripping the threads, press down on accumulator cover, then install the bolts.

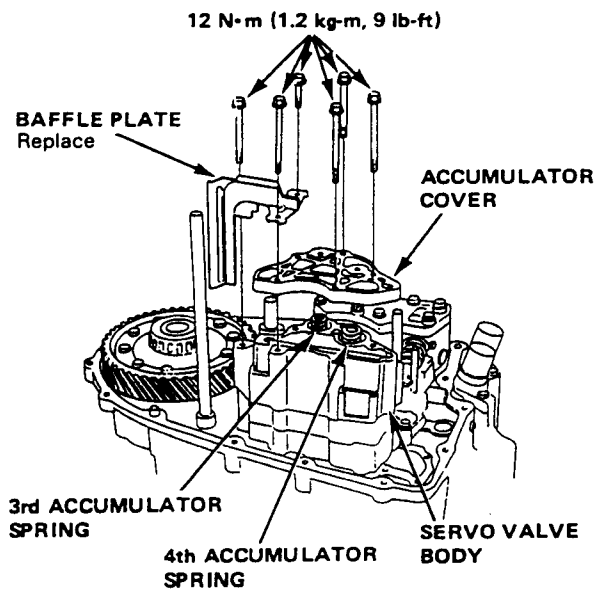

21. Install the 2nd accumulator spring and piston in the 2nd accumulator body.
22. Install the 2nd accumulator body assembly on the torque converter housing.

**CAUTION:** To prevent stripping the threads, press down on 2nd accumulator body assembly, then install the bolts.

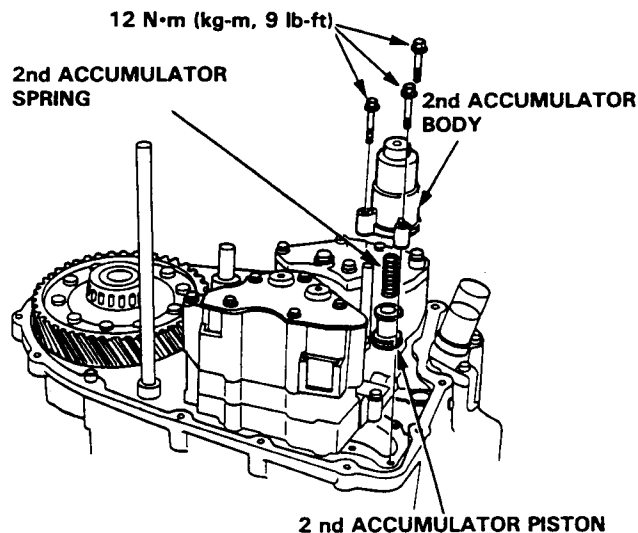

23. Install the shift control solenoid valve B in the main valve body and the shift control solenoid A valve in the servo valve body. Pass the connector through a hole to the outside of the valve body, install the connector in the torque converter housing, then install the rubber seal.

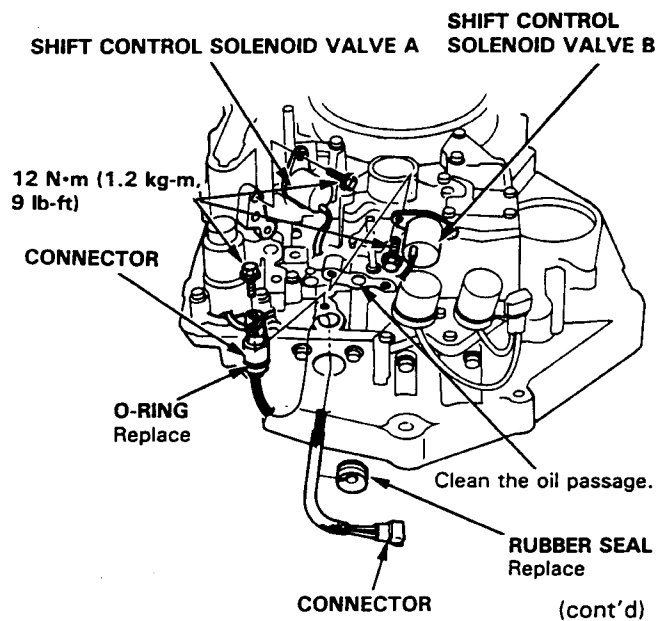

# Transmission

## Reassembly (cont'd)

24. Put the rollers on each side of the manual valve stem, then attach the valve to the lever with the pin. Secure with the cotter pin.

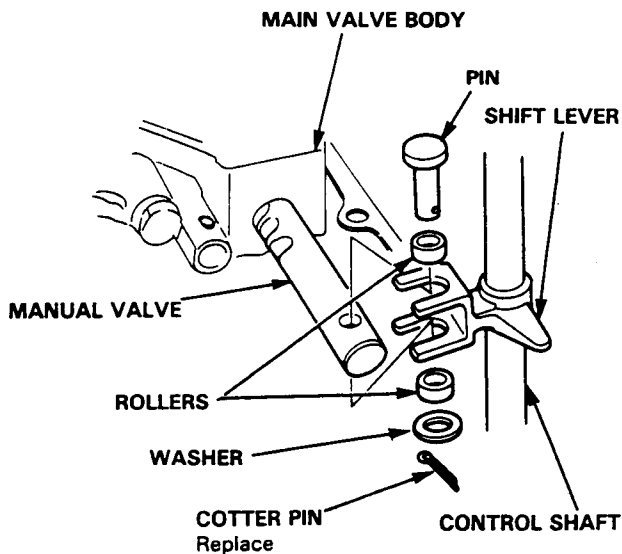

25. Install the 1st, 3rd and 4th clutch feed pipes.

**CAUTION:** Do not install feed pipes by force.

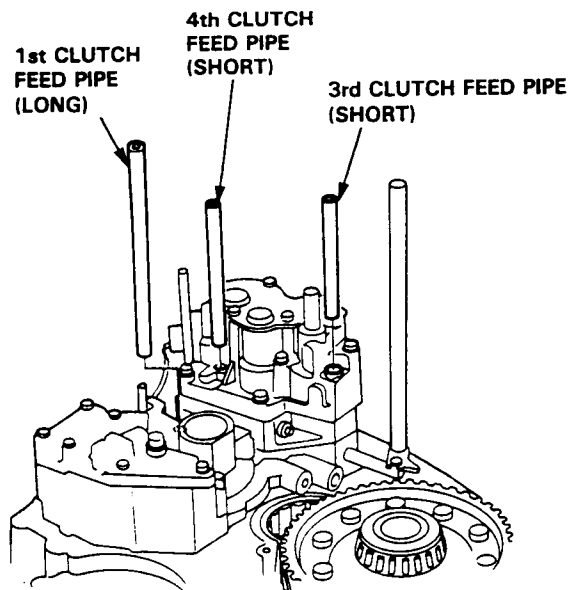

26. Install the transmission pulser rotor using new lock plates, and the three 6 mm bolts. Bend the tabs on the lock plate to secure.

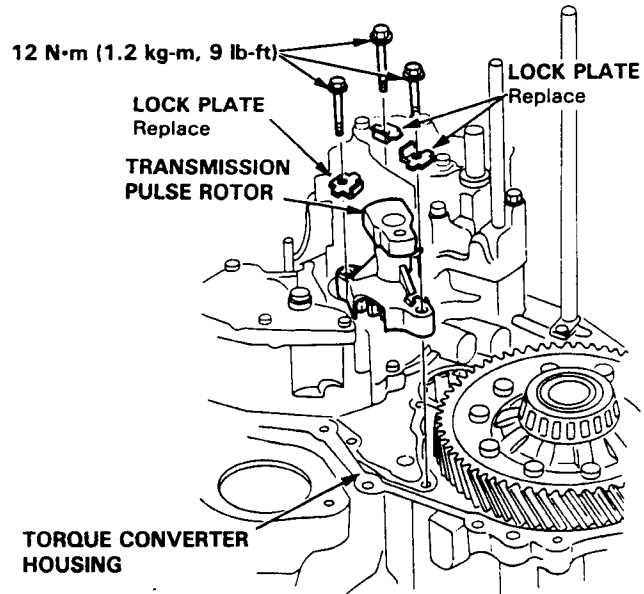

27. Set the countershaft and mainshaft in place as an assembly.

**NOTE:** Do not tap on the shafts with a hammer to drive in.

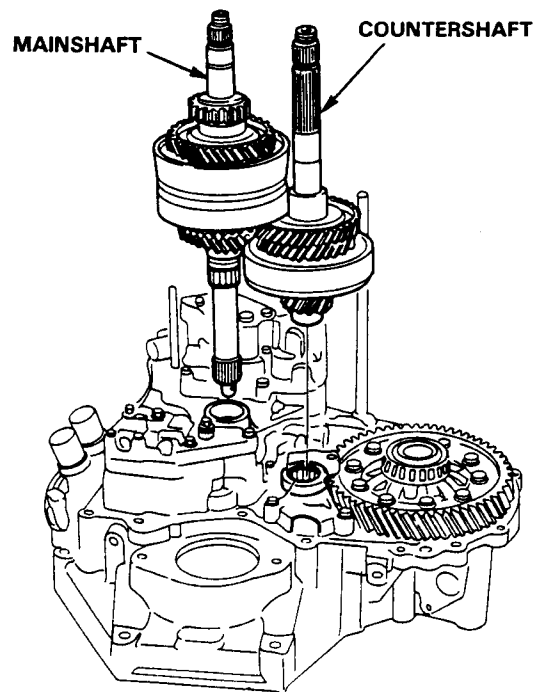

28. Install the distance collar, needle bearing, countershaft 4th gear, reverse shaft fork, reverse gear selector and reverse selector hub.

**NOTE:**

- Install the reverse gear selector with its flat face up.
- Install the reverse gear selector hub with the groove facing up.

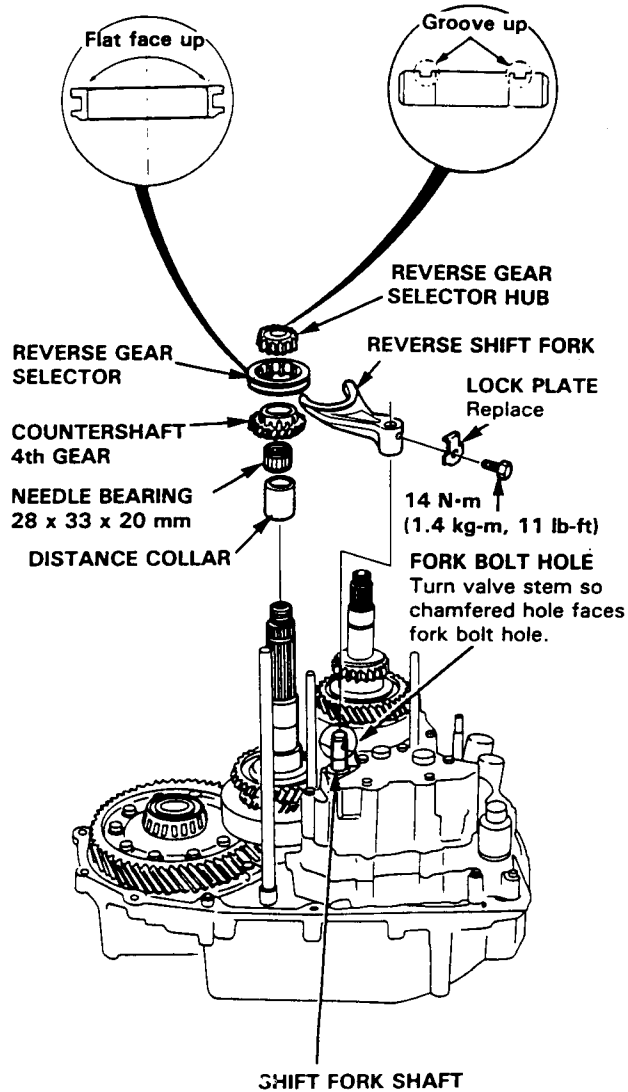

29. Install the reverse shift fork over the servo valve stem. Align the hole in the stem with hole in fork as shown, and install the bolt and new lock plate. Bend the lock tab against the bolt head.

30. Install the countershaft reverse gear, needle bearing, and reverse gear collar.

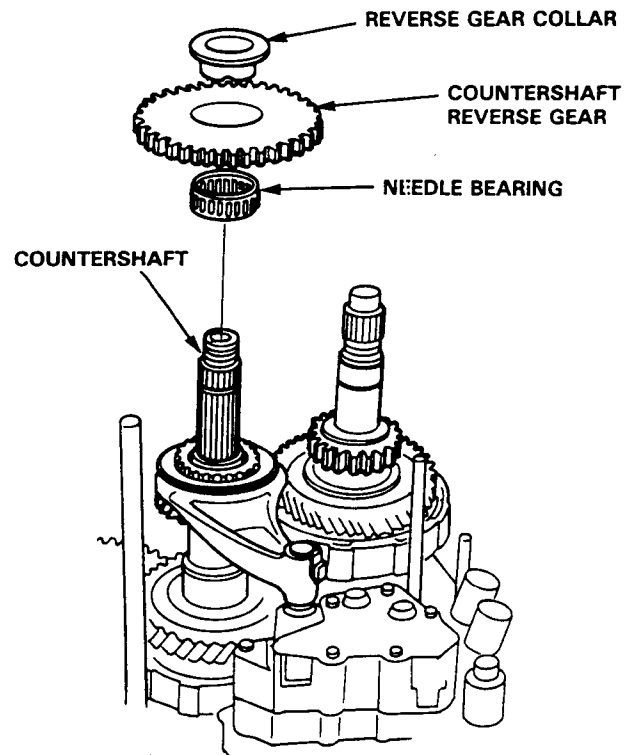

31. Install the new gasket and three dowel pins in the torque converter housing.

**NOTE:** Dowel pins are different in length. Be sure to install properly.

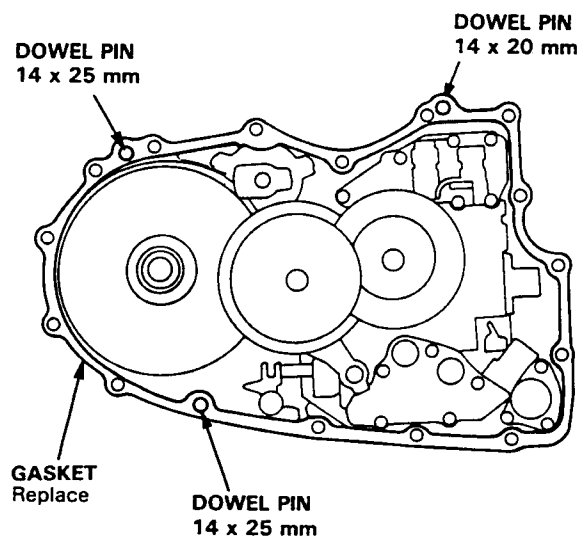

(cont'd)

# Transmission

## Reassembly (cont'd)

32. Place the transmission housing on the torque converter housing.

NOTE: Be sure the main valve control shaft lines up with the hole in the housing and that the reverse idler gear meshes with the mainshaft and countershaft, or the housing will not go on.

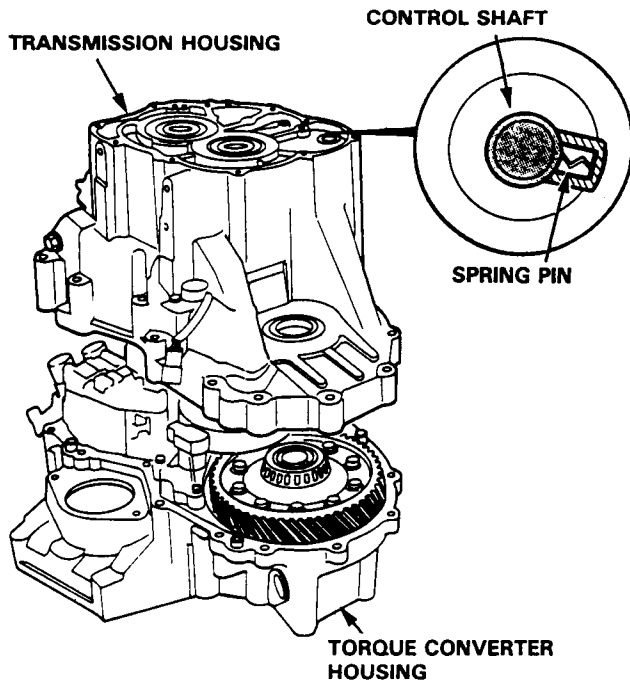

33. Torque bolts to 55 N·m (5.5 kg-m, 40 lb-ft) in order of (1) thru (16) in two or more steps.

NOTE: When tightening the transmission housing bolts, take care that you do not distort or damage the throttle control bracket; distortion or damage to the bracket will change transmission shift points.

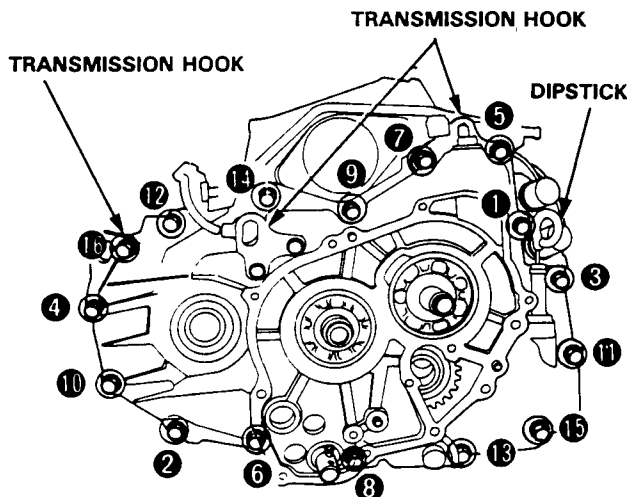

34. Install the throttle control lever and spring on the throttle control shaft.

35. Install the bolt and new lock plate. Bend the lock tab against the bolt head.

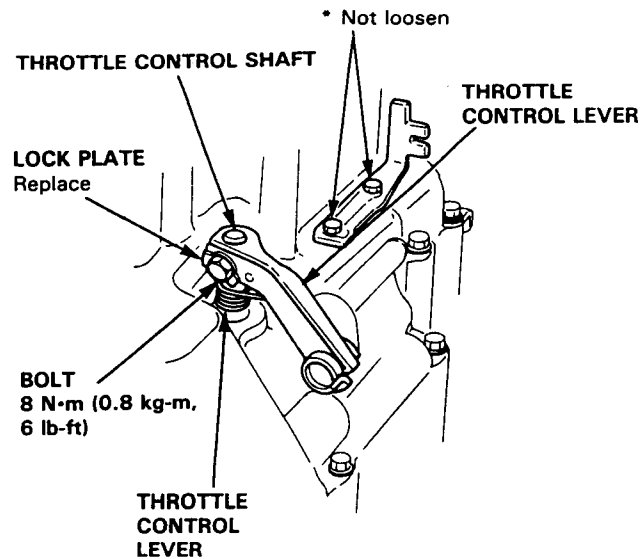

36. Install the parking brake roller, roller pin and washer on the parking shift arm and secure with a new cotter pin.

37. Install the parking brake spring, parking shift arm and parking brake stopper on the shift shaft with the bolt. Bend the lock tab against the bolt head.

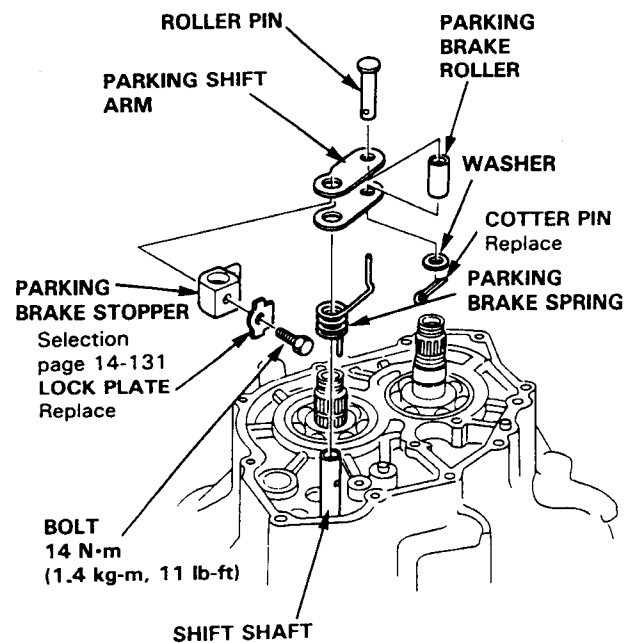

38. Install the countershaft 1st gear collar and needle bearing on the countershaft. Install the 1st gear collar and new O-rings on the mainshaft.

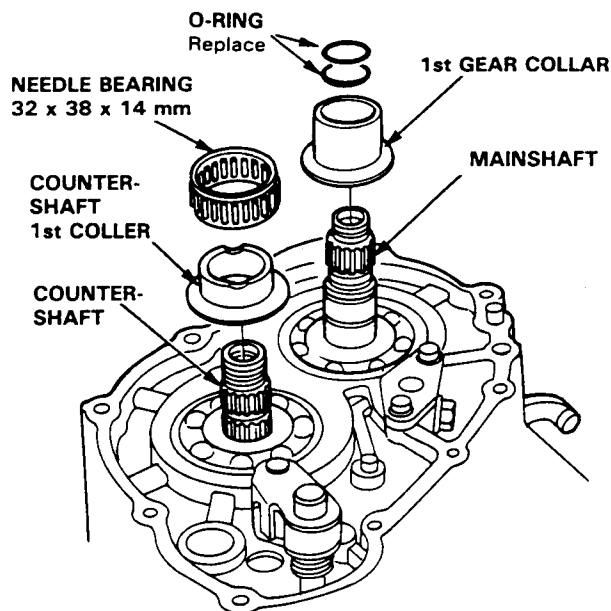

39. Install the parking gear and countershaft 1st gear on the countershaft with a 30 mm socket wrench and mallet. Loosely install a new lock nut on the countershaft.

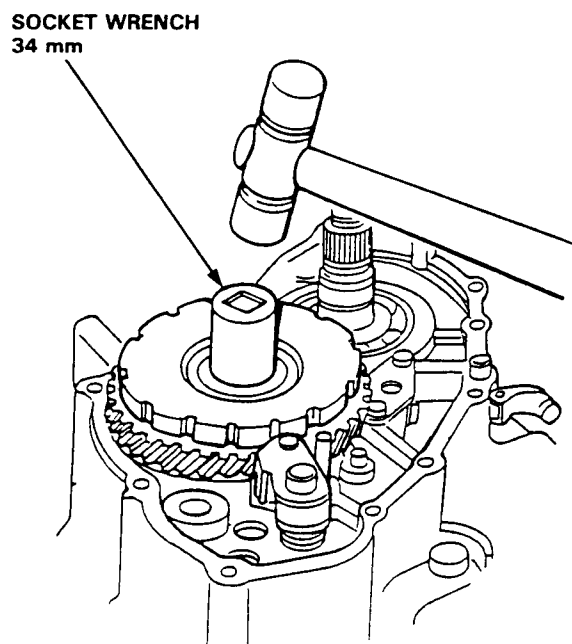

40. Install the stop pin, parking pawl shaft parking pawl, and pawl release spring.

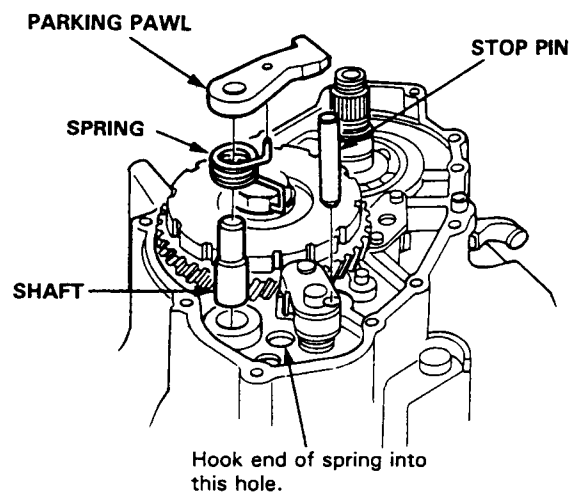

**NOTE:**

- One end of the parking pawl release spring fits into the hole in the parking pawl, the other end into the hole in the transmission housing as shown.
- The release spring should put clockwise tension on the pawl, forcing it away from the parking gear.

41. Shift to PARK and install the mainshaft holder.
42. Install and torque the new countershaft locknut. Tighten to specified torque, then loosen and retighten to same torque.

**COUNTERSHAFT LOCK NUT**

140 → 0 → 140 N·m  
 (14.0 → 0 → 14.0 kg·m, 102 → 0 → 102 lb·ft)

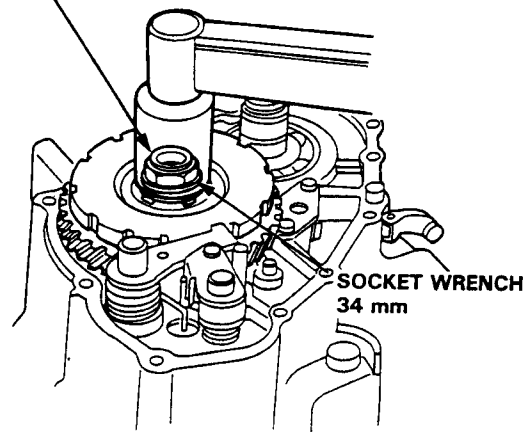

(cont'd)



# Transmission

## Reassembly (cont'd)

43. Stake the lock nut flange at two places into the gear grooves using a 3.5 mm punch.

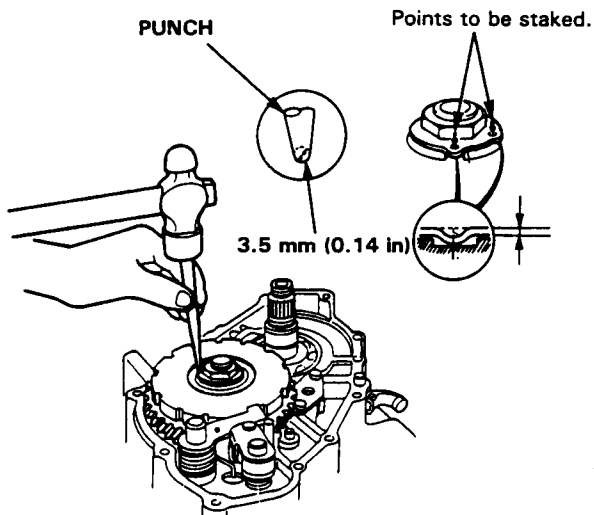

44. Install 31 x 36 x 18.5 mm needle bearing and thrust washer on the mainshaft.

45. Install 1st gear, thrust needle bearing, and the thrust washer on the mainshaft.

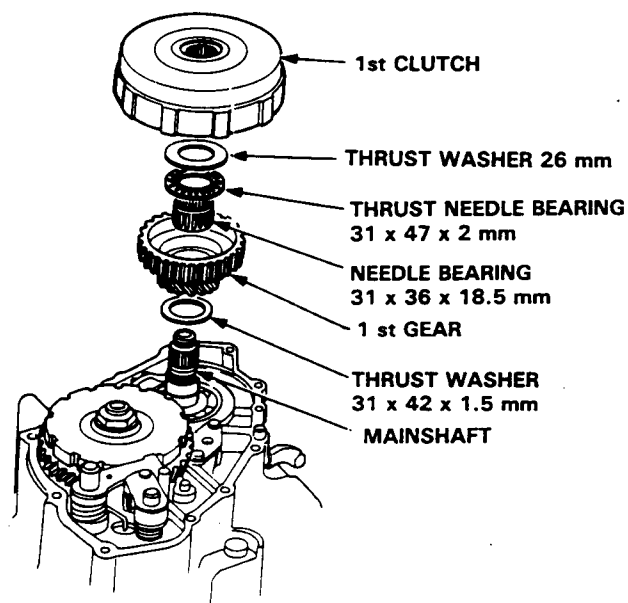

46. Install the 1st clutch assembly on the mainshaft.

47. Attach the mainshaft holder from the underside of the torque converter case.

48. Torque the new mainshaft lock nut.

Tighten to specified torque, then loosen and retighten to same torque.

**CAUTION:** Lock nut has left-hand threads.

**LOCK NUT 19 mm**  
95 → 0 → 95 N·m  
(9.5 → 0 → 9.5 kg-m, 70 → 0 → 70 lb-ft)

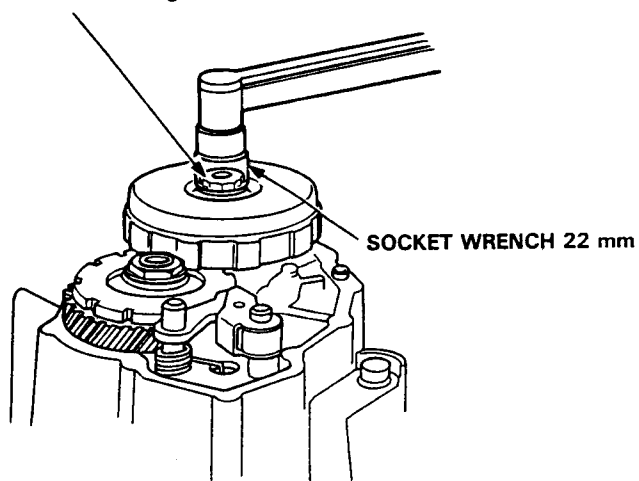

49. Stake the lock nut flange into the groove in the 1st clutch.

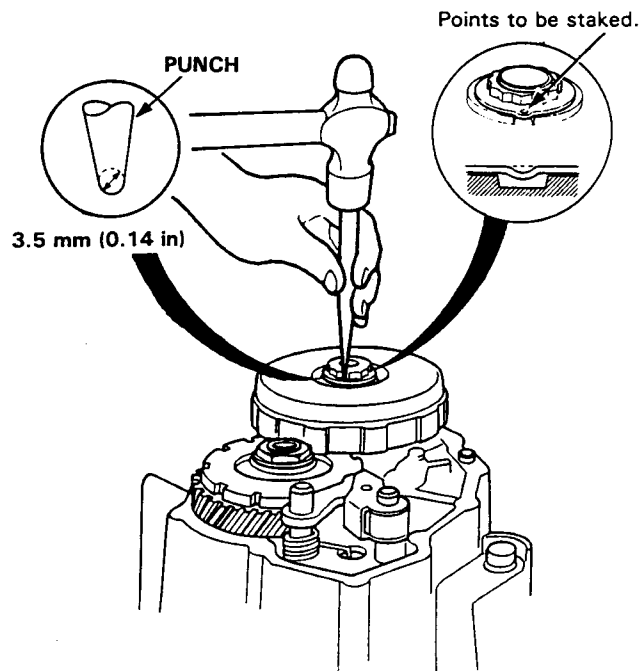

# Parking Brake Stopper

## Inspection/Adjustment

1. Set the parking shift arm in the PARK position.
2. Measure the distance between the outer face of the parking pawl shaft and outer face of the parking shift arm roller pin.

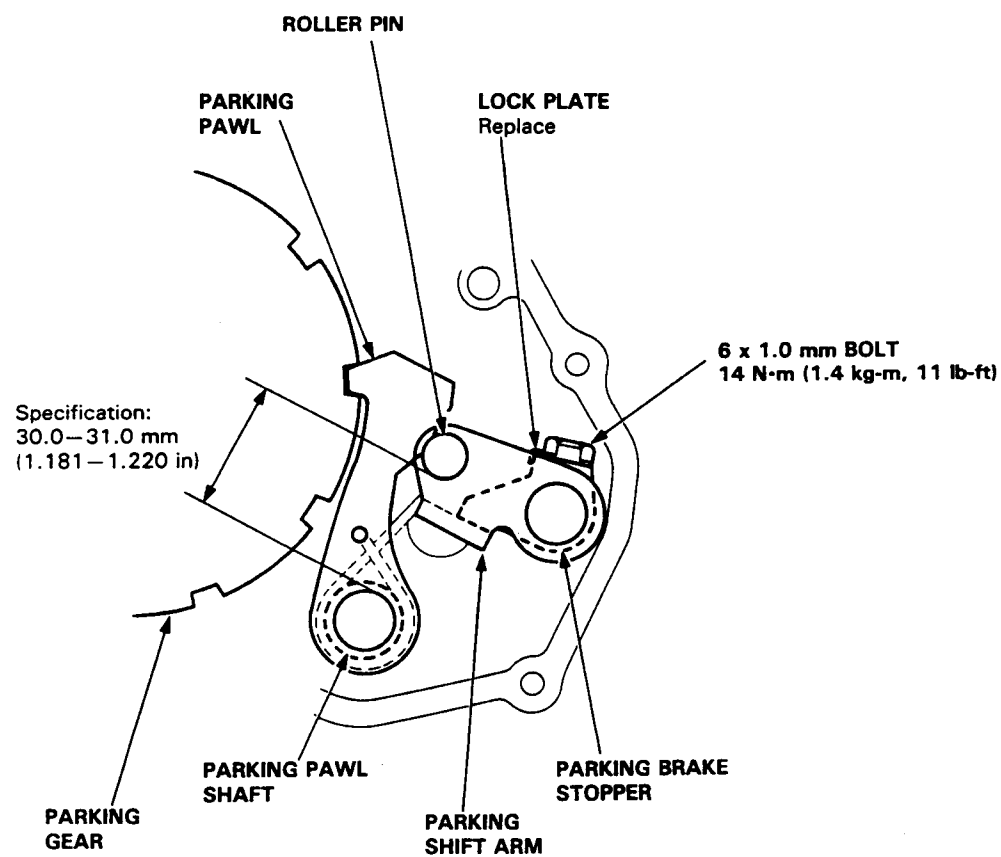

3. If the measurement is out of specification, select the appropriate parking brake stopper using the table below, and install it on the parking shift arm.

No.	PART NUMBER
1	24537-PA9-003
2	24538-PA9-003
3	24539-PA9-003

# Transmission Housing

## Reassembly

1. Install the gasket, dowel pins, and O-rings on the transmission housing.

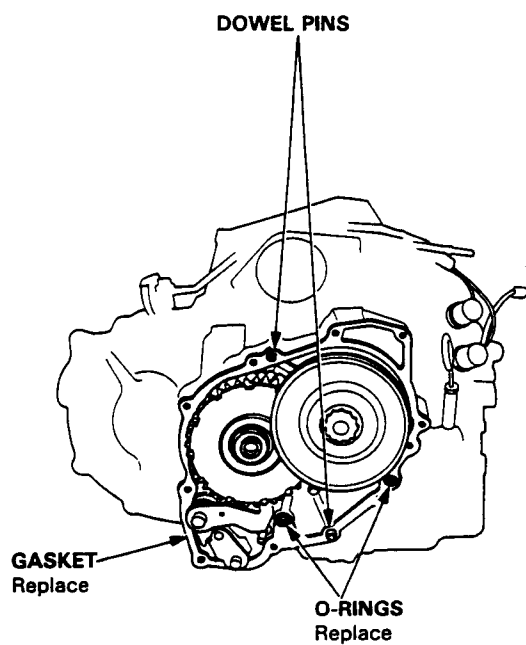

2. Install the end cover and torque all 10 bolts to 12 N·m (1.2 kg·m, 9 lb·ft).

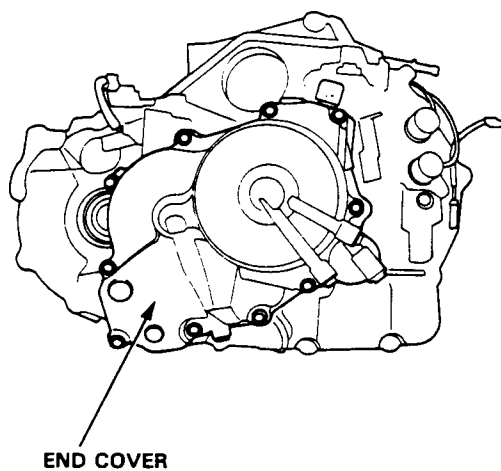

3. Install the transmission oil cooler pipes A and B on the transmission housing with new sealing washers.

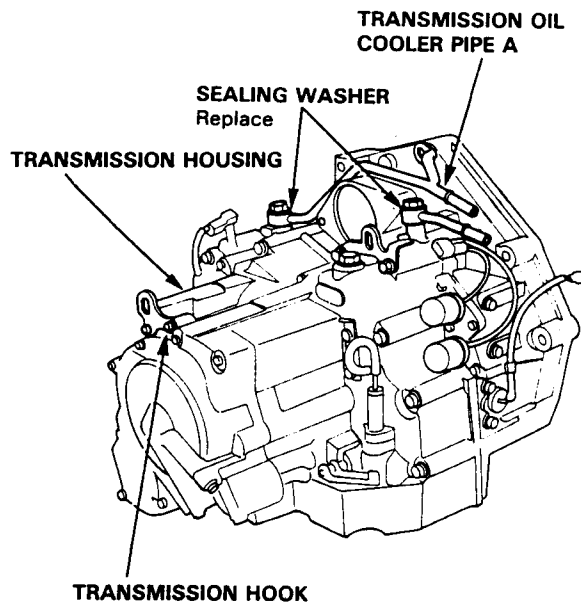

4. Install the speed sensor assembly.

NOTE: Speed sensor assembly removal/installation is required only if the power steering is to be overhauled.

BOLT  
12 N·m (1.2 kg·m, 9 lb·ft)

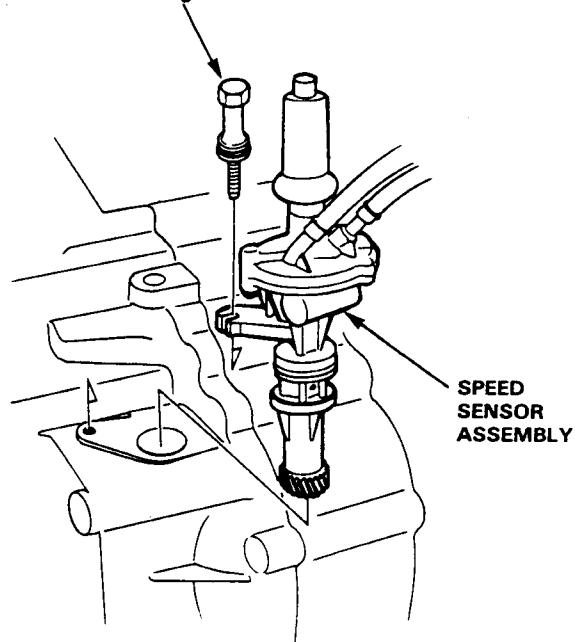

# Torque Converter

## Disassembly

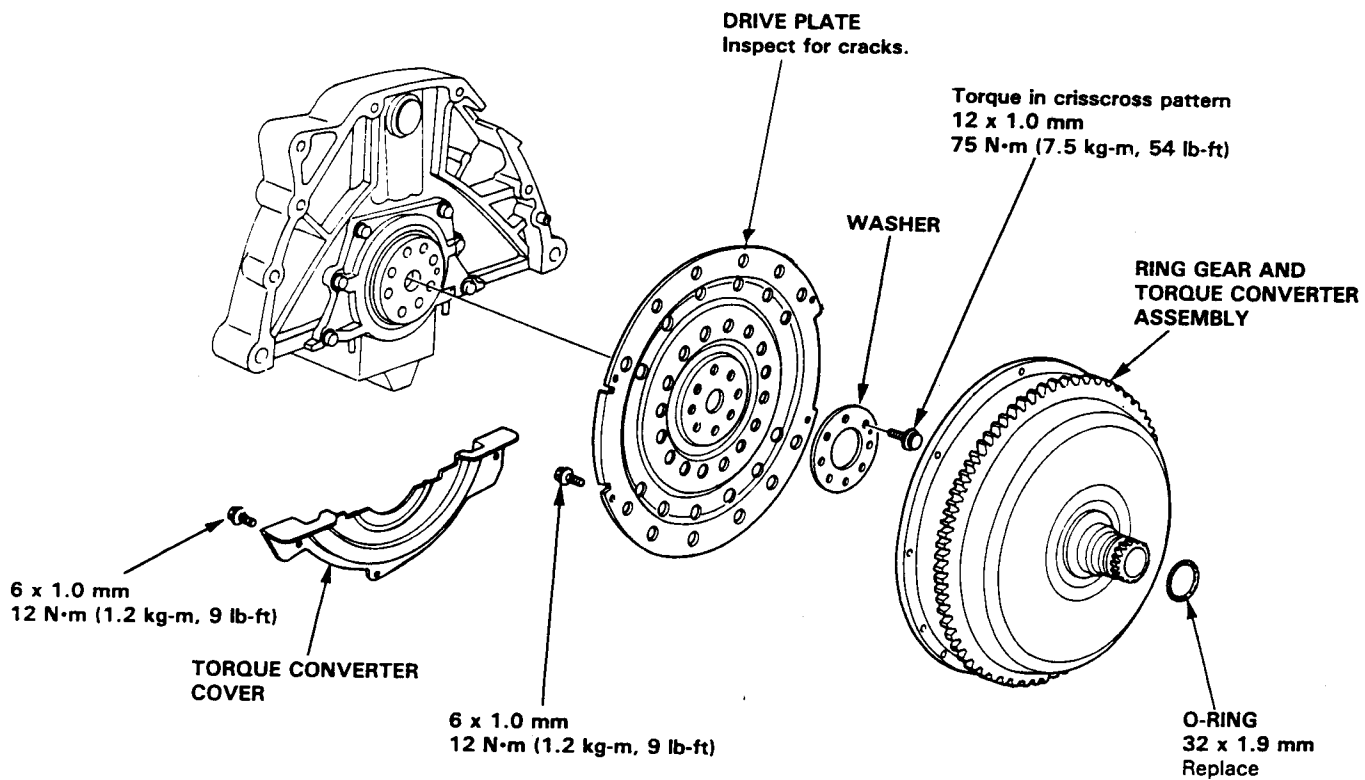

# Transmission

## Installation

1. Place the transmission on the transmission jack and raise to the engine level.
2. Secure the transmission to the engine with the mounting bolts.
3. Attach the torque converter to the drive plate with mounting bolts, and torque to 12 N·m (1.2 kg·m, 9 lb-ft). Rotate the crank as necessary to tighten bolts to 1/2 torque, then final torque, in a crisscross pattern. Check for free rotation after tightening the last bolt.
4. Install the transmission to the rear engine mount bracket with mounting bolts.

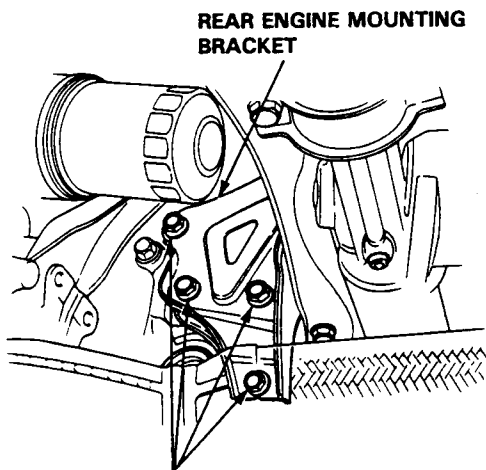

**SPECIAL BOLTS**  
75 N·m (7.5 kg·m, 54 lb-ft)  
Replace

5. Install the shift control cable and fasten in with the control pin and the split pin.

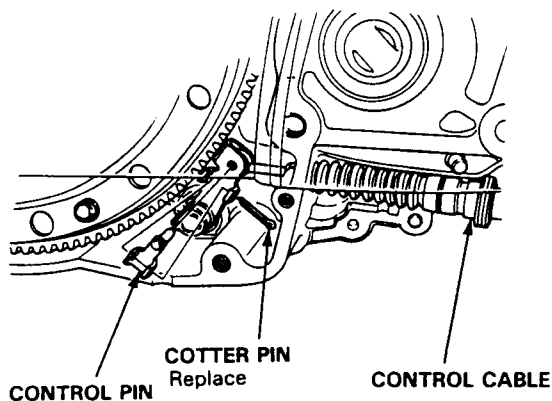

6. Install the torque converter covers.
7. Install the cable holder.

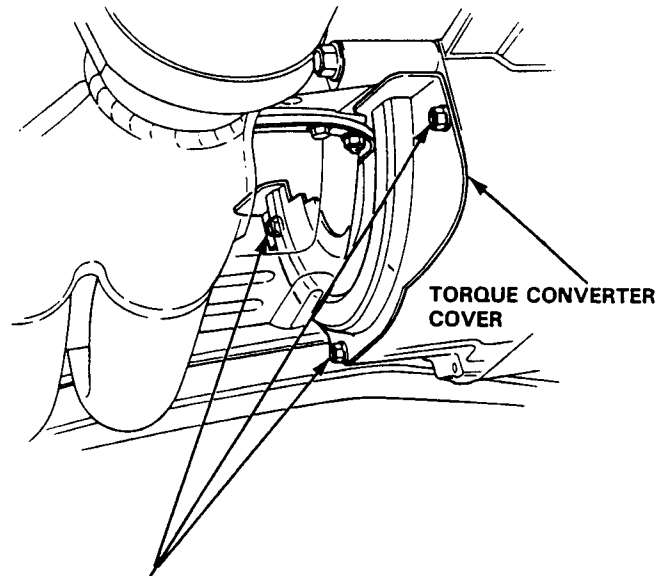

12 N·m (1.2 kg·m, 9 lb-ft)

8. Install the engine stiffener.

**NOTE:** Tighten bolts 1 to 4 in order to torque specified below.

39 N·m (3.9 kg·m, 28 lb-ft)

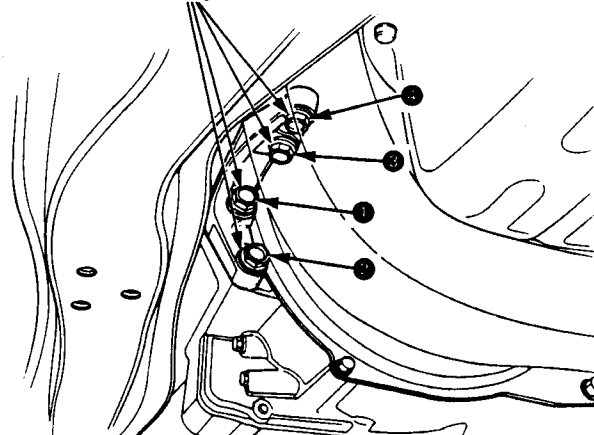

9. Install the intermediate shaft.

10. Install the right and left drive shaft.

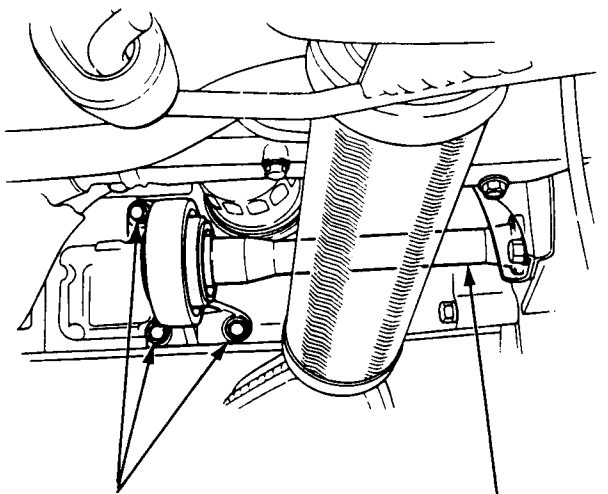

10 x 1.25 BOLT  
39 N·m (3.9 kg-m, 28 lb-ft)

INTERMEDIATE SHAFT

11. Install the center beam.

12. Install the right and left front damper fork.

13. Install the radius rod on the transmission side.

14. Install the transmission mounting bracket.

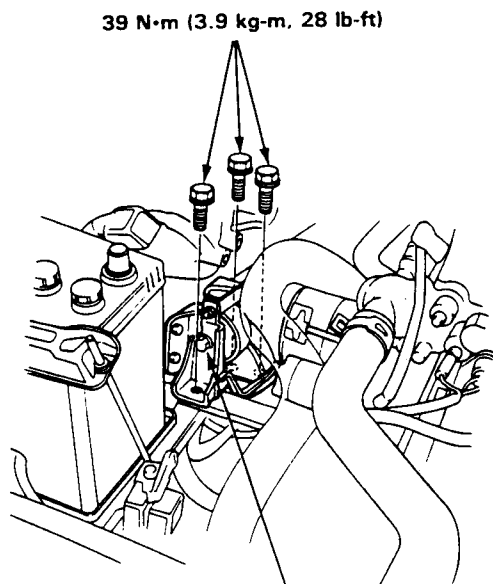

39 N·m (3.9 kg-m, 28 lb-ft)

75 N·m (7.5 kg-m, 54 lb-ft)

15. Connect the lock-up control solenoid valve connector, the shift control solenoid valve coupler and connector of the speed pulser.

16. Connect the oil cooler inlet and outlet hoses.

17. Connect the throttle control cable to the throttle control lever.

18. Install the speed sensor assembly.

19. Install the air cleaner case.

20. Connect the starter and ground cables.

21. Refill the transmission with DEXRON-II type automatic transmission fluid.

22. Connect the battery positive (+) and negative (-) cables to the battery.

23. Start the engine, set the parking brake, and shift the transmission through all gears three times. Check for proper control cable adjustment.

24. Let the engine reach operating temperature with the transmission in Neutral or Park, then turn it off and check the fluid level.

# Gearshift Selector

## Disassembly/Reassembly

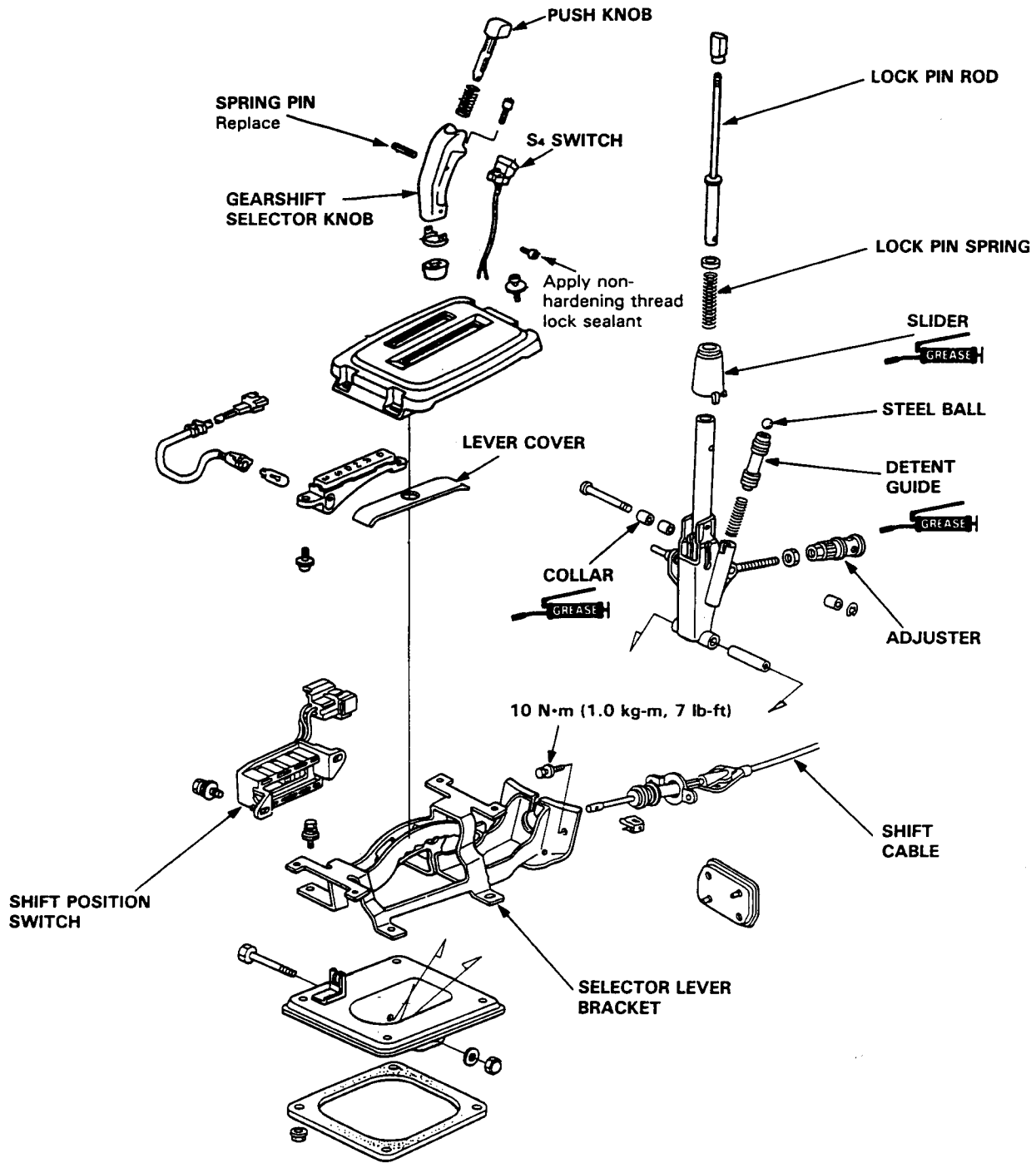

## Shift Indicator Light

### Check and Installation

1. Check for continuity between indicator light connector terminals as shown. If there is no continuity, check for a burned out bulb or open circuit.

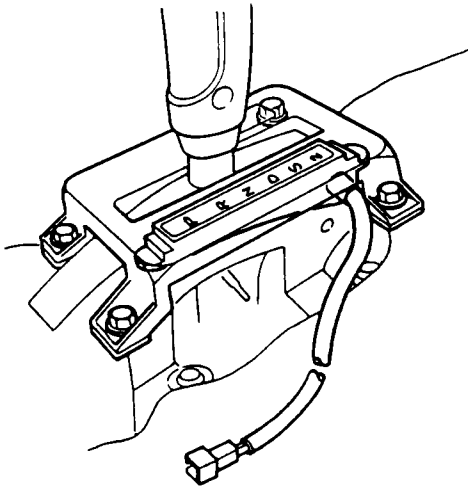

2. Install the indicator bulb in the bulb housing. Insert the bulb housing into the slot in the escutcheon, then turn 90° to bulb housing.

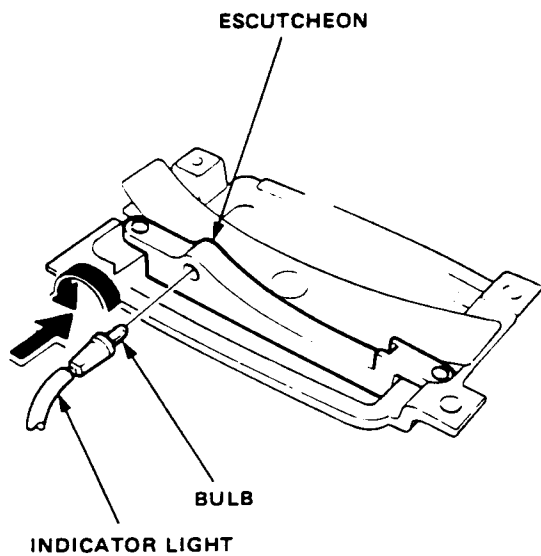

## Shift Indicator Panel

### Adjustment

1. Check that the index mark of the indicator aligns with the N mark of the shift indicator panel with the transmission in NEUTRAL.
2. If not aligned, remove the panel mounting screws and adjust by moving the panel.

NOTE: Whenever the escutcheon is removed for indicator bulb replacement etc., reinstall the panel as described above.

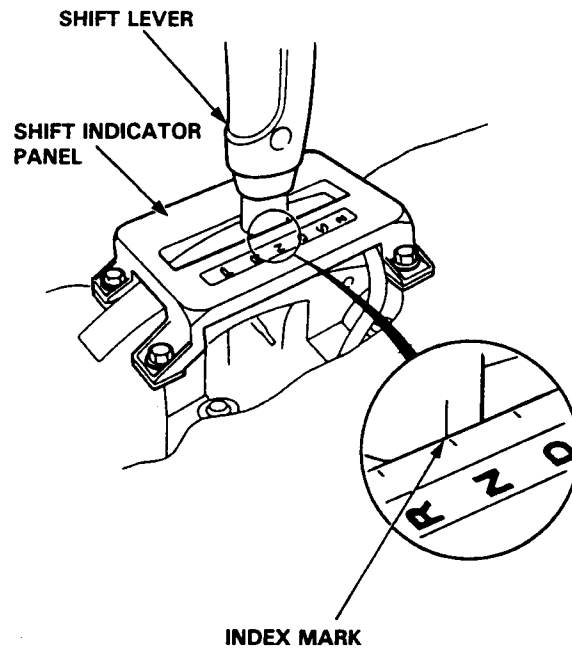



# Shift Cable

## Removal

NOTE: Shift to **2** position before removal.

1. Remove the consol and disconnect shift cable by removing the lock pin.
2. Remove the selector lever bracket bolts from inside the car.
3. Remove the shift cable bracket bolt from outside of the car.  
[6 x 1.0 mm Bolt torque 10 N·m (1.0 kg-m, 7 lb-ft)]
4. Remove the bolts for the shift cable rubber from outside of the car.

NOTE: Slide the rear steering cover by removing bolts. (4WS only)

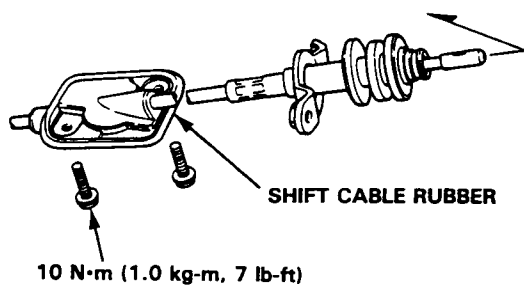
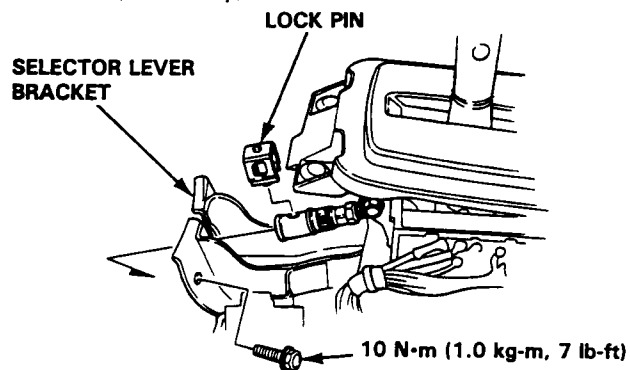

5. Remove the cable holder.

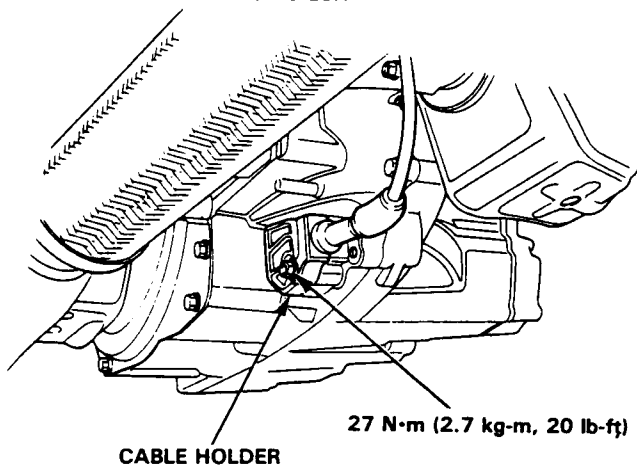

6. Remove the engine stiffener.

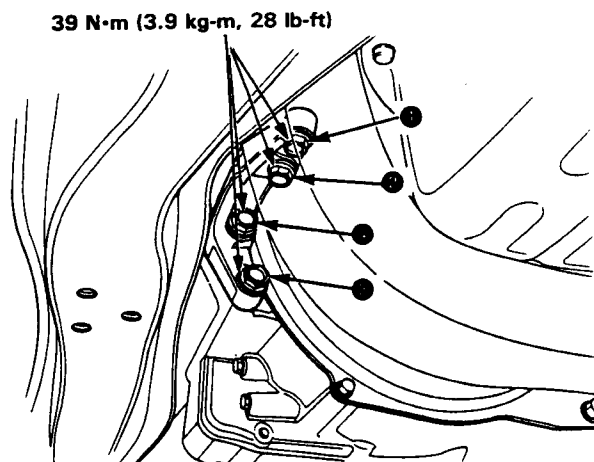

7. Remove the torque converter cover.

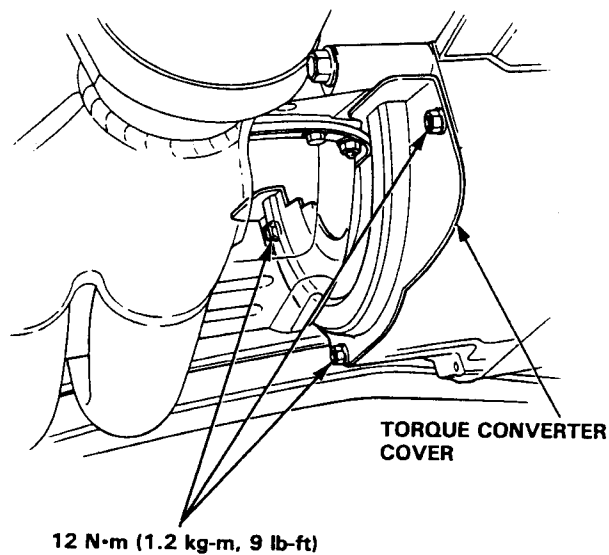

8. Remove the shift cable by removing the control pin.

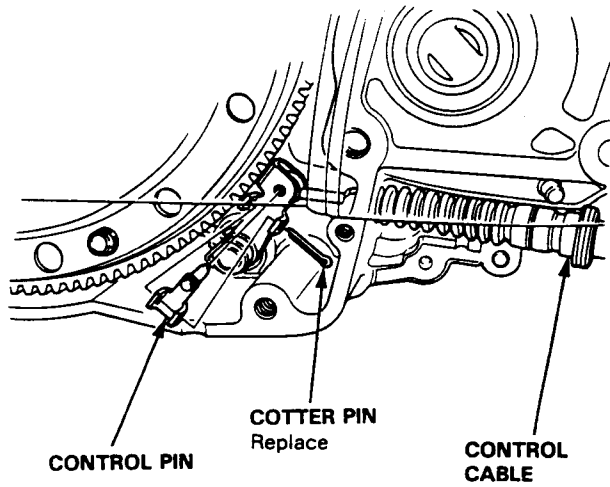

9. Pull the shift cable out of the by setting slot.

**CAUTION:** Do not bend the shift cable excessively.

## Installation

1. Installation is in the reverse order of removal.

**NOTE:** When installing the engine stiffener, loosely install the bolts then, torque them in the order shown.

39 N·m (3.9 kg-m, 28 lb-ft)

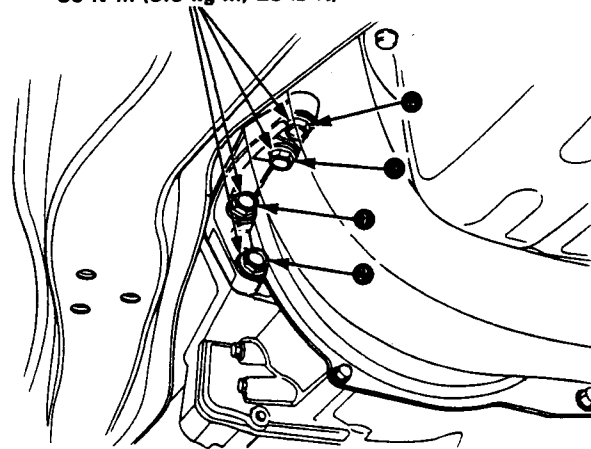

- Shift cable adjustment Page

## Adjustment

1. Start the engine. Shift to reverse to see if the reverse gear engages. If not, refer to Troubleshooting on pages 14-66 and 67.
2. With the engine off, remove the console.
3. Shift to **N** or **R** position, then remove the lock pin from the cable adjuster.

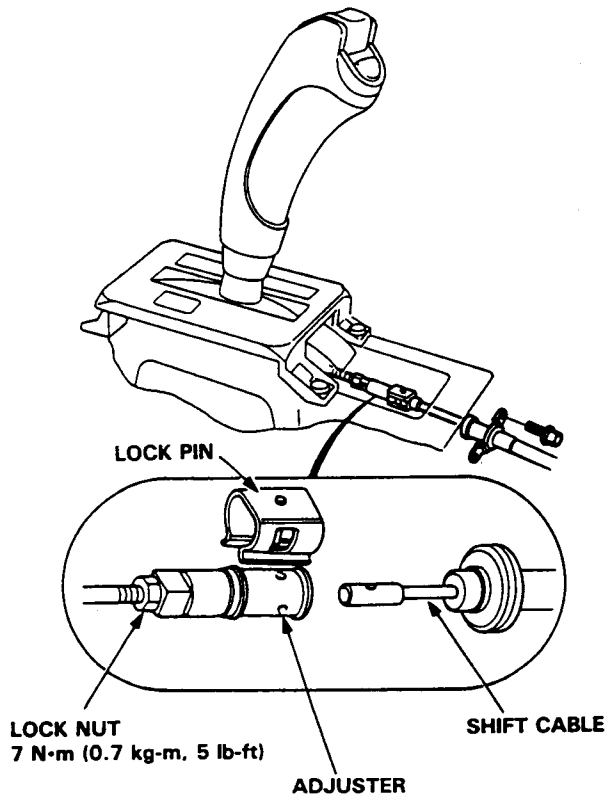

4. Check that the hole in the adjuster is perfectly aligned with the hole in the shift cable.

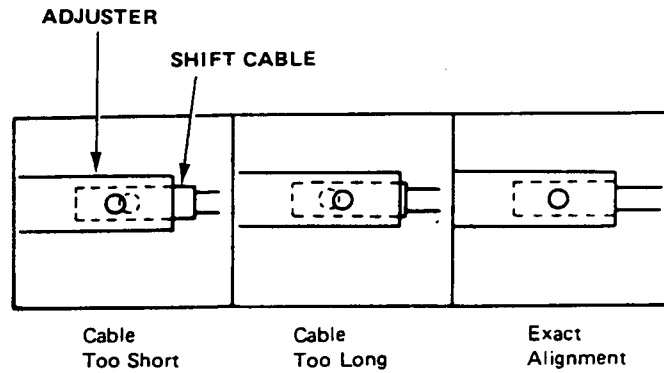

**NOTE:** There are two holes in the end of the shift cable. They are positioned 90° apart to allow cable adjustments in 1/4 turn increments.

5. If not perfectly aligned, loosen the lock nut on shift cable and adjust as required.
6. Tighten the lock nut.
7. Install the lock pin on the adjuster.

**NOTE:** If you feel the lock pin binding as you reinstall it, the cable is still out of adjustment and must be readjusted.

8. Start the engine and check the shift lever in all gears. If any gear does not work properly, refer to troubleshooting on pages 14-66 and 67.

# Throttle Control Cable Bracket

## Adjustment (Carbureted Engine)

1. Disconnect the throttle control cable from the throttle control lever.
2. Adjust the tool to 157.0 mm (6.18 in.) using vernier calipers then tighten the wing nut.
3. Bend down the lock tabs of the lock plate and remove the two 6 mm bolts to free the bracket.
4. Loosely install a new lock plate.
5. Position the special tool between the throttle control lever and the bracket as shown.
6. Position the bracket so that there is no binding between the bracket and the special tool (tolerance 0 to + 0.3 mm). Then tighten the two 6 mm bolts, bend up the lock plate tabs against the bolts heads.

**CAUTION:** Make sure the control lever doesn't get pulled toward the bracket side as you tighten the bolts.

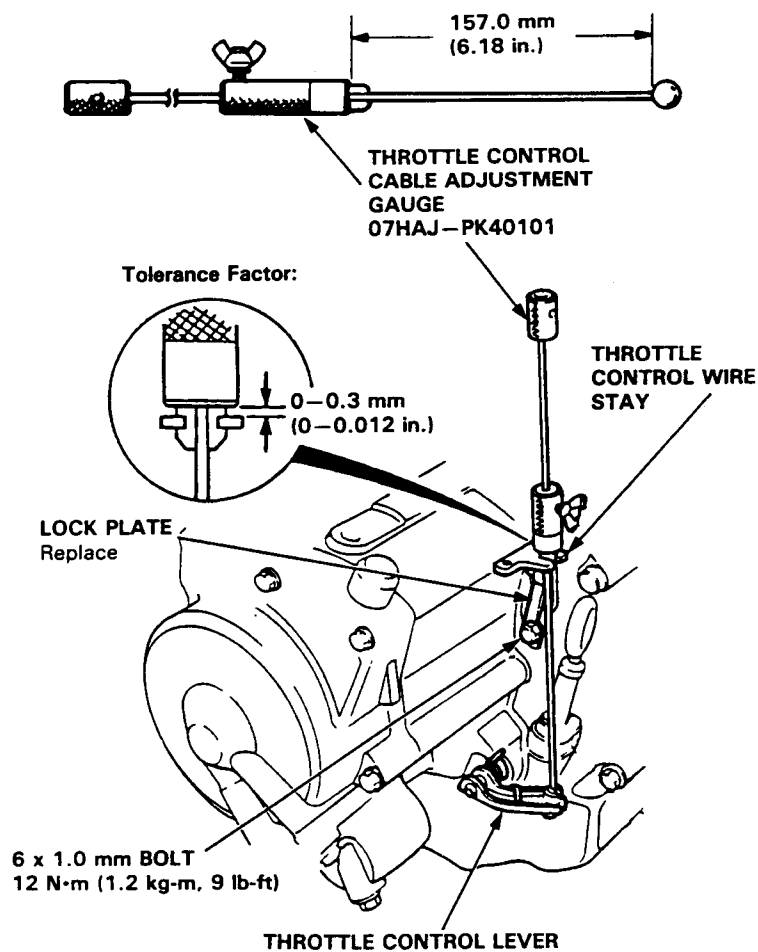

# Throttle Control Cable

## Adjustment/Inspection

NOTE: Before adjusting the throttle control cable, make sure:

- The throttle cable free play is correct.
- The engine is at normal operating temperature (cooling fan comes on).
- The idle speed is correct.
- On carbureted cars the distance between the throttle control lever and the throttle control bracket is correct (See "Throttle Control Cable Bracket Adjustment.")

Inspection:

NOTE: On carbureted cars you will need an assistant to depress the accelerator pedal, on fuel-injected cars you can work the throttle linkage body with your hand.

1. Remove the throttle cable free play.
2. Apply light thumb pressure to the throttle control lever, then work the accelerator or throttle linkage. The lever should move just as the engine speed increases above idle. If not, proceed to Adjustment.

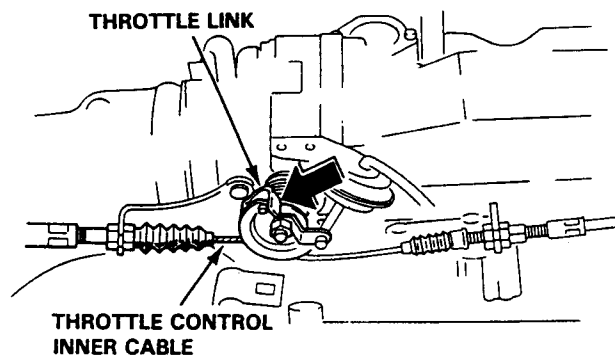

**Adjustment:**

1. Loosen the nuts on the control cable at the transmission end and synchronize the control lever to the throttle.

**NOTE:** To tailor the shift/lock-up characteristics to a particular customer's driving expectations, you can adjust the control cable up to 3 mm shorter than the "synchronized" point.

