



[PREVIOUS](#)
[MENU](#)

INDEX

[GO TO MENU](#)

ADJUSTMENTS	4
TROUBLE-SHOOTING	6
STALL TESTS	8
ELECTRICAL CONTROLS	14
DISASSEMBLY	20
COMPONENT GROUP	26
VALVE BODY	50
GOVERNOR	55
FOUR WHEEL DRIVE	59
ASSEMBLY	71

AUTOMATIC TRANSMISSION SERVICE GROUP



INTRODUCTION

TOYOTA A-55 TRANSAXLE

The A-55 Transaxle is a front wheel drive fully automatic transmission with both 2 and 4 wheel drive applications. Troubleshooting, teardown-assembly, removal and installation is fully covered.

This transmission is currently found in the Toyota Tercel models.

We thank Toyota Corporation for the illustrations and information that made this booklet possible.

ROBERT D. CHERRNAY
TECHNICAL DIRECTOR

DALE ENGLAND
FIELD SERVICE CONSULTANT

FRANK MIETUS
TECHNICAL CONSULTANT

WAYNE COLONNA
TECHNICAL CONSULTANT

WELDON BARNETT
TECHNICAL CONSULTANT

ED KRUSE
LAY OUT

AUTOMATIC TRANSMISSION SERVICE GROUP
9200 SOUTH DADELAND BLVD.
SUITE 720
MIAMI, FLORIDA 33156
(305) 661-4161

NOTES---NOTES---NOTES---NOTES



Technical Service Information

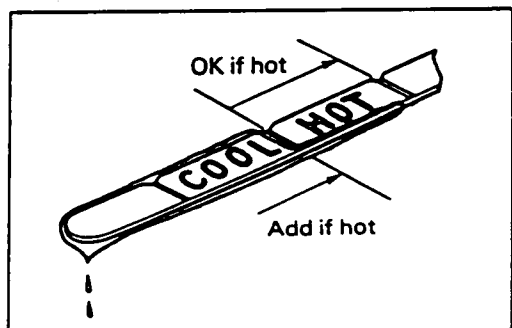

ATF INSPECTION

CHECK FLUID LEVEL (See page MA-20)

CHECK FLUID CONDITION

If the fluid smells burnt or is black, replace it.

REPLACE FLUID (See page MA-16)

ADJUSTMENTS

ADJUSTMENT OF THROTTLE LINK

REMOVE AIR CLEANER

CHECK THAT CARBURETOR THROTTLE LEVER AND THROTTLE LINK BRACKET ARE NOT BENT

PUSH ON CARBURETOR THROTTLE LEVER AND CHECK THAT THROTTLE VALVE OPENS FULLY

If the throttle valve does not open fully, adjust the accelerator cable.

FULLY DEPRESS ACCELERATOR

Using a pedal jack, fully depress and hold the accelerator pedal.

ADJUST THROTTLE LINK

- (a) Loosen the turnbuckle lock nut and adjust the linkage length by turning the turnbuckle.
- (b) When the carburetor throttle valve is fully open, the throttle valve lever indicator should line up with the mark on the transmission case.

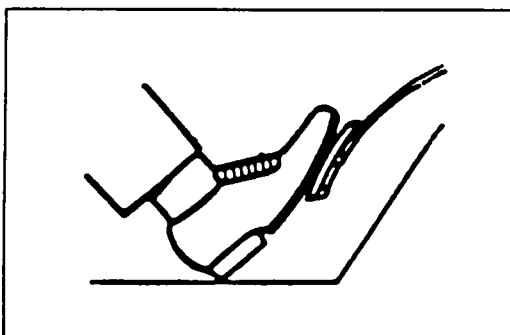
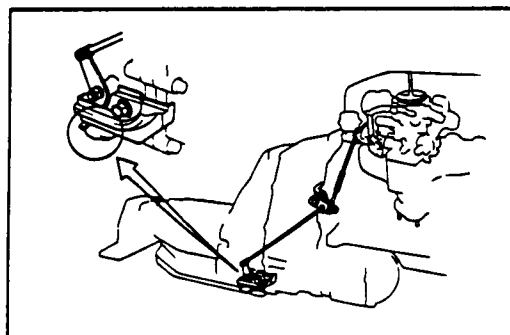
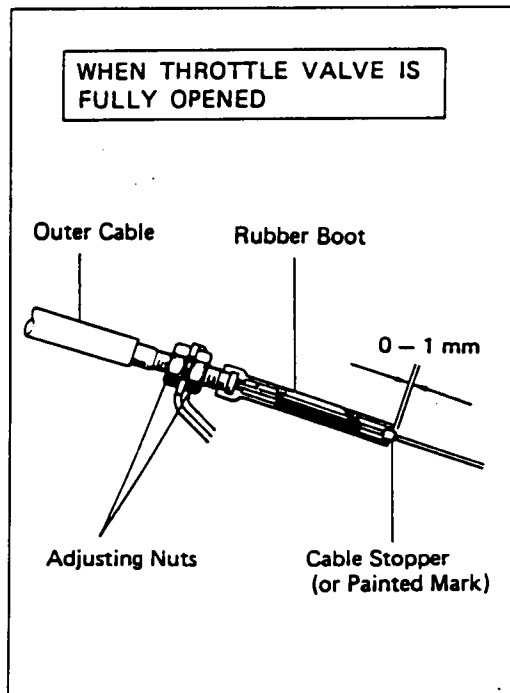

(c) Tighten the turnbuckle lock nut.

(d) Recheck the adjustments.

INSTALL AIR CLEANER



Technical Service Information

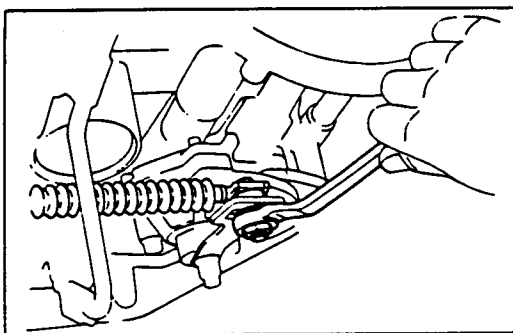

ADJUSTMENT OF FLOOR SHIFT LINKAGE

INSPECT CONNECTING ROD BUSHING FOR WEAR OR DEFORMATION

LOOSEN NUT ON CONNECTING ROD

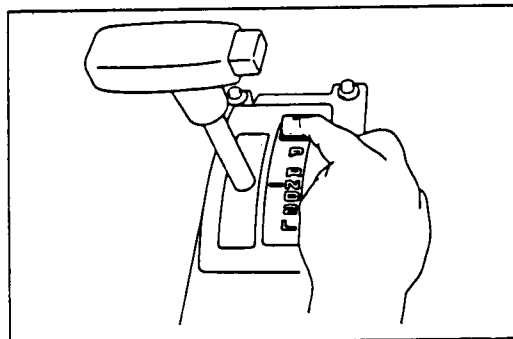

ADJUST SHIFT LINKAGE

- Push the manual lever fully rearward.
- Return the lever two notches to the NEUTRAL position.
- Set the shift selector to "N".
- While holding the selector slightly toward the "R" range, tighten the connecting rod nut.

ADJUSTMENT OF NEUTRAL START SWITCH

If the engine will start with the shift selector in any range other than "N" or "P" range, adjustment is required.

LOOSEN NEUTRAL START SWITCH BOLT

SET SHIFT SELECTOR IN "N"

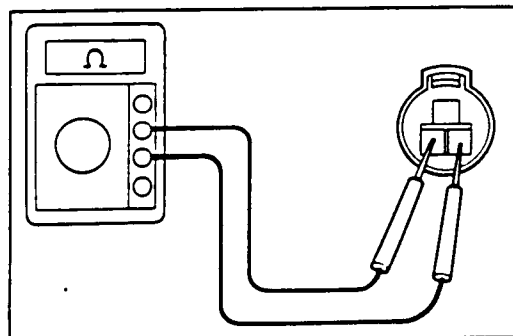

ADJUST NEUTRAL START SWITCH

- Disconnect the neutral start switch connector.
- Connect the ohmmeter between the terminals.
- Adjust the switch to the point where there is continuity between terminals 2 and 3.
- Connect the neutral start switch connector.

TORQUE NEUTRAL START SWITCH BOLT

Torque: 130 kg-cm (9 ft-lb, 13 N·m)

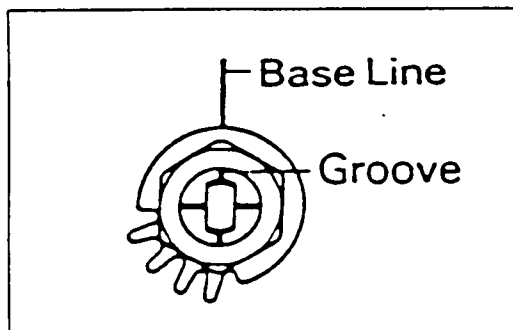



TROUBLESHOOTING

Problem	Possible cause	Remedy
Fluid discolored or smells burnt	Fluid contaminated Torque converter faulty Transmission faulty	Replace fluid Replace torque converter Disassemble and inspect transmission
Vehicle does not move in any forward range or reverse	Manual linkage out of adjustment Valve body or primary regulator faulty Transmission faulty	Adjust linkage Inspect valve body Disassemble and inspect transmission
Vehicle does not move in any range	Park lock pawl faulty Valve body or primary regulator faulty Torque converter faulty Converter drive plate broken Oil pump intake strainer blocked Transmission faulty	Inspect park lock pawl Inspect valve body Replace torque converter Replace torque converter Clean strainer Disassemble and inspect transmission
Shift lever position incorrect	Manual linkage out of adjustment Manual valve and lever faulty Transmission faulty	Adjust linkage Inspect valve body Disassemble and inspect transmission
Harsh engagement into any drive range	Throttle linkage out of adjustment Valve body or primary regulator faulty Accumulator pistons faulty Transmission faulty	Adjust throttle linkage Inspect valve body Inspect accumulator pistons Disassemble and inspect transmission
Delayed 1-2 or 2-3 up-shift, or down-shifts from 3-2 then shifts back to 3	Throttle linkage out of adjustment Governor faulty Valve body faulty	Adjust throttle linkage Inspect governor Inspect valve body
Slips on 1-2 or 2-3 up-shift, or slips or shudders on take-off	Manual linkage out of adjustment Throttle linkage out of adjustment Valve body faulty Transmission faulty	Adjust linkage Adjust throttle linkage Inspect valve body Disassemble and inspect transmission
Drag, binding or tie-up on 1-2 or 2-3 up-shift	Manual linkage out of adjustment Valve body faulty Transmission faulty	Adjust linkage Inspect valve body Disassemble and inspect transmission



Technical Service Information

Problem	Possible cause	Remedy
Harsh down-shift	Throttle linkage out of adjustment Accumulator pistons faulty Valve body faulty Transmission faulty	Adjust throttle linkage Inspect accumulator pistons Inspect valve body Disassemble and inspect transmission
No down-shift when coasting	Governor faulty Valve body faulty	Inspect governor Inspect valve body
Down-shift occurs too quick or too late while coasting	Throttle linkage out of adjustment Governor faulty Valve body faulty Transmission faulty	Adjust throttle linkage Inspect governor Inspect valve body Disassemble and inspect transmission
No. 3-2 or 2-1 kick-down	Throttle linkage out of adjustment Governor faulty Valve body faulty	Adjust throttle linkage Inspect governor Inspect valve body
No engine braking in "2" range	Valve body faulty Transmission faulty	Inspect valve body Disassemble and inspect transmission
Vehicle does not hold in "P"	Manual linkage out of adjustment Parking lock pawl cam and spring faulty	Adjust linkage Inspect cam and spring

TESTS

STALL TEST

The object of this test is to check the overall performance of the transmission and engine by measuring the maximum engine speeds in the "D" and "R" ranges.

CAUTION:

- (a) Perform this test with fluid at normal operating temperature (50 – 80°C or 122 – 176°F).
- (b) Do not perform this test for longer than 5 seconds.

MEASURE STALL SPEED

- (a) Chock the front and rear wheels.
- (b) Mount an engine tachometer.
- (c) Fully apply the parking brake.
- (d) Step down strongly on the brake pedal with your left foot.
- (e) Turn off the 4WD change-over switch.
- (f) Start the engine.
- (g) Shift into "D" range. Step all the way down on the accelerator pedal with your right foot. Quickly read the highest engine rpm at this time.

Stall speed:	3A-C	2,200 ± 150 rpm
	3A	2,250 ± 150 rpm

- (g) Perform the same test in the "R" range.

EVALUATION

- (a) If the engine speed is the same for both ranges but lower than specified value:
 - Engine output may be insufficient.
 - Stator one-way clutch may not be operating properly.

NOTE: If more than 600 rpm below the specified value, the torque converter could be at fault.

- (b) If the stall speed in "D" range is higher than specified:
 - Line pressure too low
 - Front clutch slipping
 - One-way clutch No. 2 not operating properly
- (c) If the stall speed in "R" range is higher than specified,
 - Line pressure too low
 - Rear clutch slipping
 - Brake No. 3 slipping

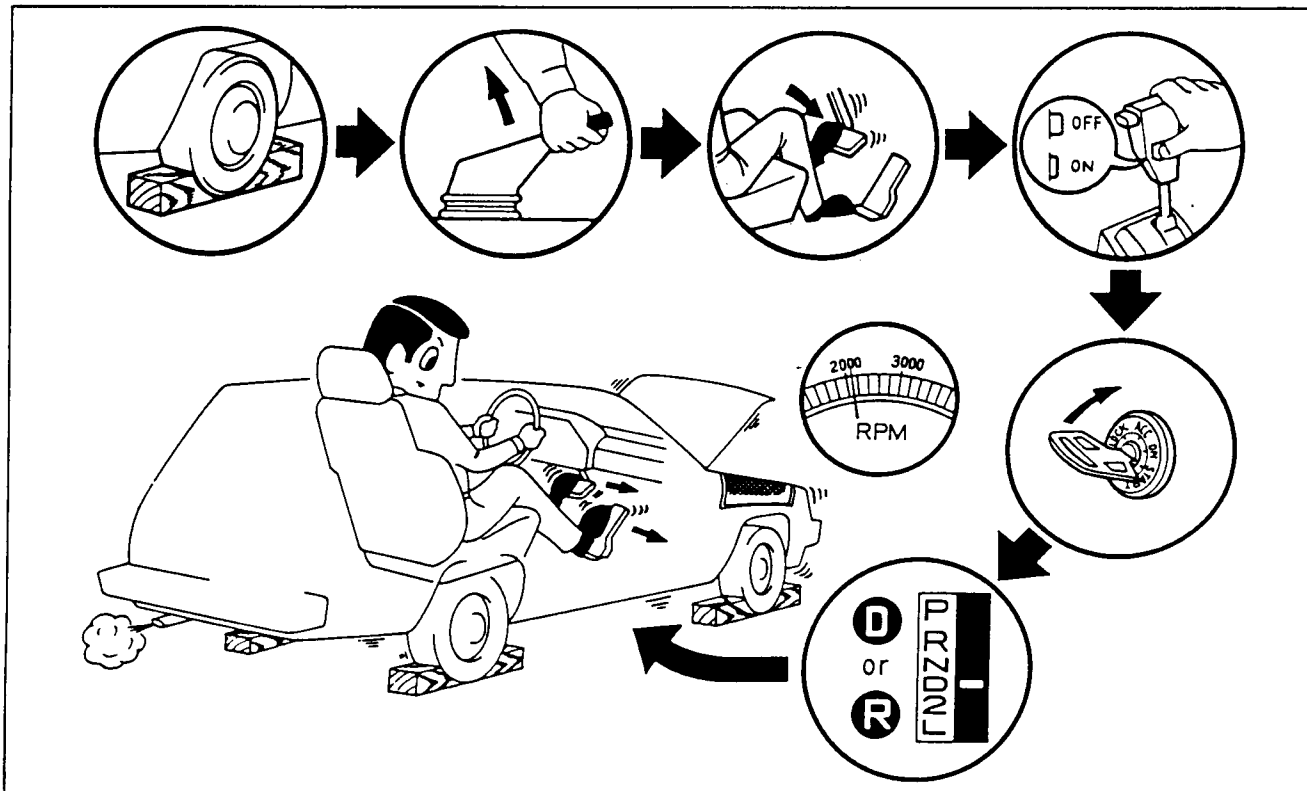



Technical Service Information

TIME LAG TEST

If the shift lever is shifted while the engine is idling, there will be a certain time elapse or lag before the shock can be felt. This is used for checking the condition of the front clutch, rear clutch and brake No. 3.

MEASURE TIME LAG

- (a) Fully apply the parking brake.
- (b) Turn off the 4WD change-over switch.
- (c) Start the engine.

Idle speed (cooling fan and A/C OFF):

w/o PS "N" range 800 rpm

w/ PS "N" range 900 rpm

- (d) Shift the shift lever from "N" to "D" range.

Using a stop watch, measure the time it takes from shifting the lever until the shock is felt.

Time lag: Less than 1.2 seconds

- (e) In same manner, measure the time lag for "N" → "R".

Time lag: Less than 1.5 seconds

CAUTION:

- (a) Perform this test with the fluid at normal operating temperature (50 – 80°C or 122 – 176°F).
- (b) Allow a one minute interval between tests.
- (c) Make three measurements and calculate the average value.

EVALUATION

- (a) If "N" → "D" time lag is longer than specified,
 - Line pressure too low
 - Front clutch worn
- (b) If "N" → "R" time lag is longer than specified,
 - Line pressure too low
 - Rear clutch worn
 - Brake No. 3 worn

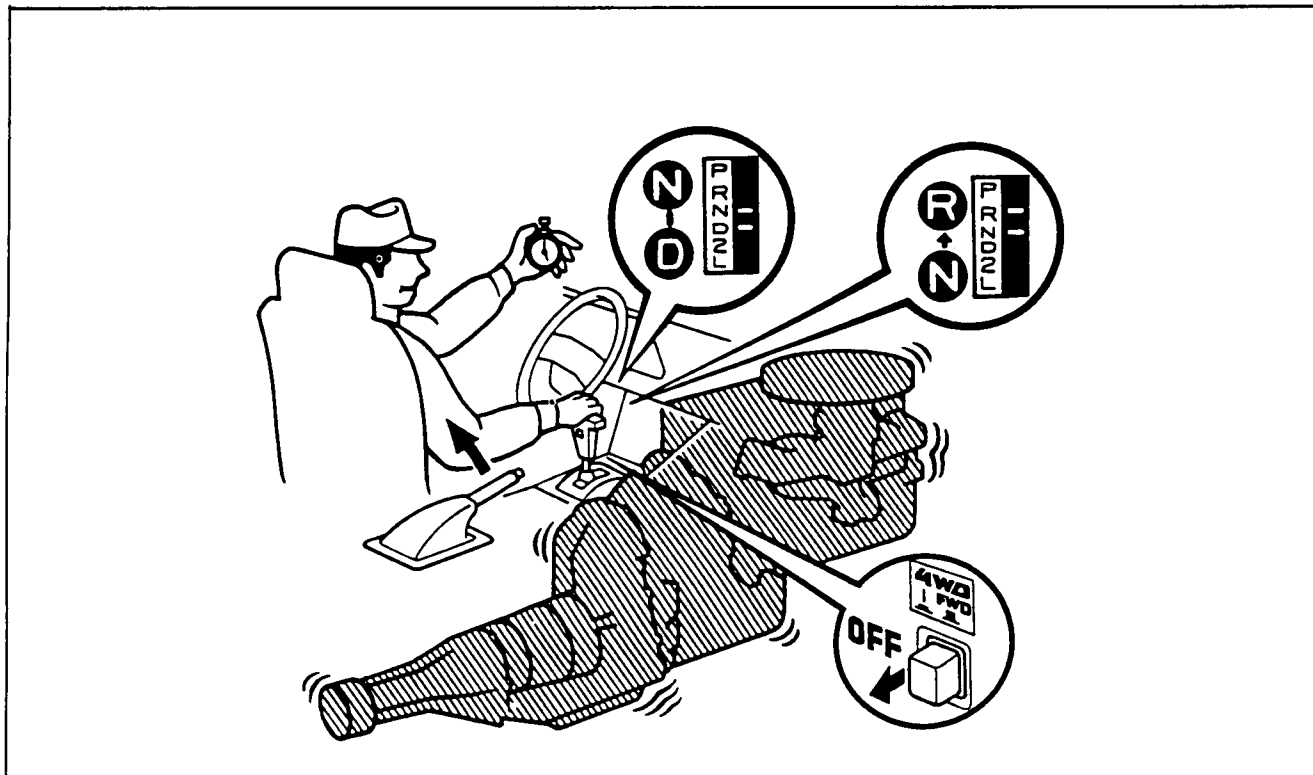

HYDRAULIC TEST

PREPARATION

- Warm up the transmission fluid.
- Turn off the 4WD change-over switch.
- Chock the rear wheels.
- Jack up the vehicle and support it on stands.
- Remove the transmission case test plugs and mount the hydraulic pressure gauges.

SST 09992-00093 and 09992-00130 -

CAUTION:

- Perform this test with the fluid at normal operating temperature (50 – 80°C or 122 – 176°F).

- Measurement can be made with the 1,000 rpm test, but if tests are to be made at 1,800 and 3,500 rpm, it would be safer to test on a road or chassis dynamometer because an on-stand test could be hazardous.

MEASURE GOVERNOR PRESSURE

- Fully apply the parking brake.
- Start the engine.
- Shift into "D" range and measure the governor pressures at the speeds specified in the table.

EVALUATION

If governor pressure is defective,

- Line pressure defective
- Fluid leakage in governor pressure circuit
- Governor valve operation defective

	Output shaft	Vehicle speed (Reference only)	Governor pressure
A55	1,000 rpm	29 km/h (18 mph)	1.2 – 1.8 kg/cm ² (17 – 26 psi, 118 – 177 kPa)
	1,800 rpm	52 km/h (32 mph)	1.8 – 2.4 kg/cm ² (26 – 34 psi, 177 – 235 kPa)
	3,500 rpm	101 km/h (63 mph)	3.8 – 5.0 kg/cm ² (54 – 71 psi, 373 – 490 kPa)
A55F	1,000 rpm	27 km/h (17 mph)	1.2 – 1.8 kg/cm ² (17 – 26 psi, 118 – 177 kPa)
	1,800 rpm	49 km/h (30 mph)	1.8 – 2.4 kg/cm ² (26 – 34 psi, 177 – 235 kPa)
	3,500 rpm	95 km/h (59 mph)	4.2 – 5.0 kg/cm ² (60 – 71 psi, 412 – 490 kPa)

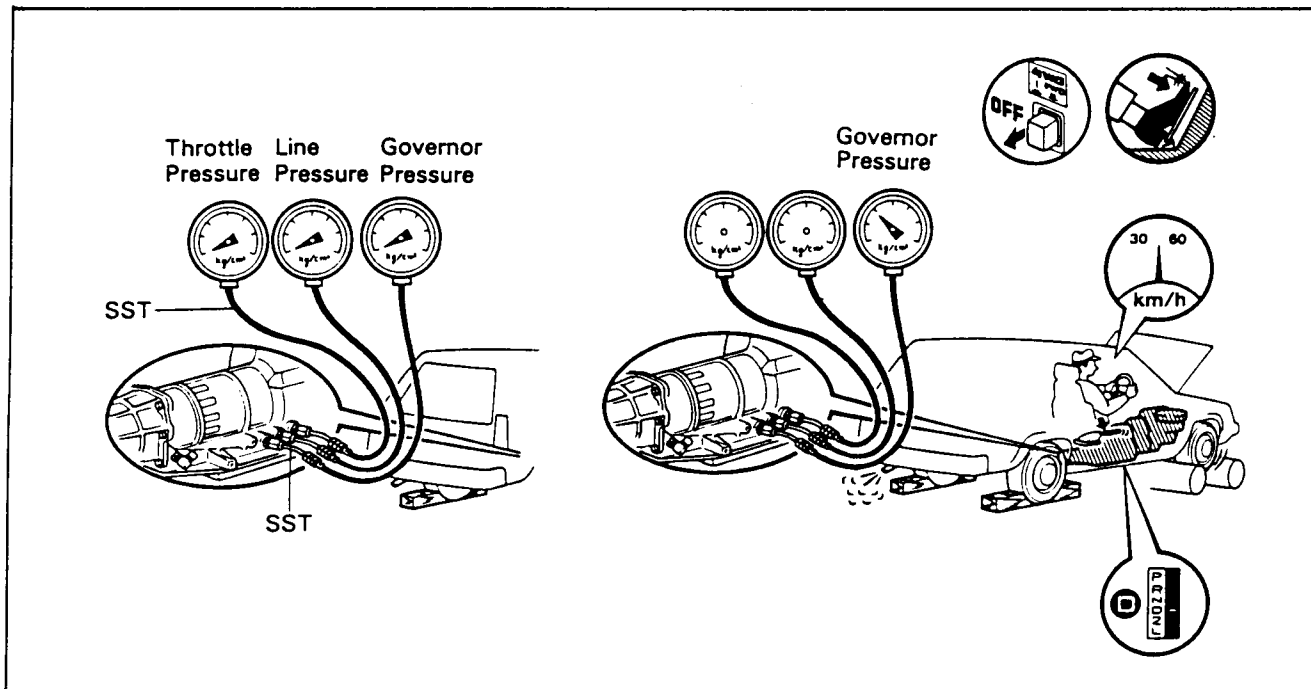

MEASURE LINE PRESSURE

- Fully apply the parking brake and chock the four wheels.
- Turn off the 4WD change-over switch.
- Start the engine and shift into "D" range.
- Step down strongly on the brake pedal with your left foot and while manipulating the accelerator pedal with the right foot, measure the line pressure at the engine speeds specified in table.
- In the same manner, perform the test for "R" range.

Engine speed rpm	Line pressure kg/cm ² (psi) (kPa)	
	"D" range	"R" range
Idling	4.0 - 4.6 (57 - 65) (392 - 451)	7.5 - 8.5 (107 - 121) (735 - 834)
Stall	9.3 - 11.3 (132 - 161) (912 - 1,108)	17.7 - 20.2 (252 - 287) (1,736 - 1,981)

- If the measured pressures are not up to specified values, recheck the throttle link adjustment and retest.

EVALUATION

- If the measured values at all ranges are higher than specified:
 - Throttle link out-of-adjustment
 - Throttle valve defective
 - Regulator valve defective
- If the measured values at all ranges are lower than specified:
 - Throttle link out-of-adjustment
 - Throttle valve defective
 - Regulator valve defective
 - Oil pump defective
- If pressure is low in "D" range only:
 - "D" range circuit fluid leakage
 - Front clutch defective
- If pressure is low in "R" range only:
 - "R" range circuit fluid leakage
 - Rear clutch defective
 - Brake No. 3 defective

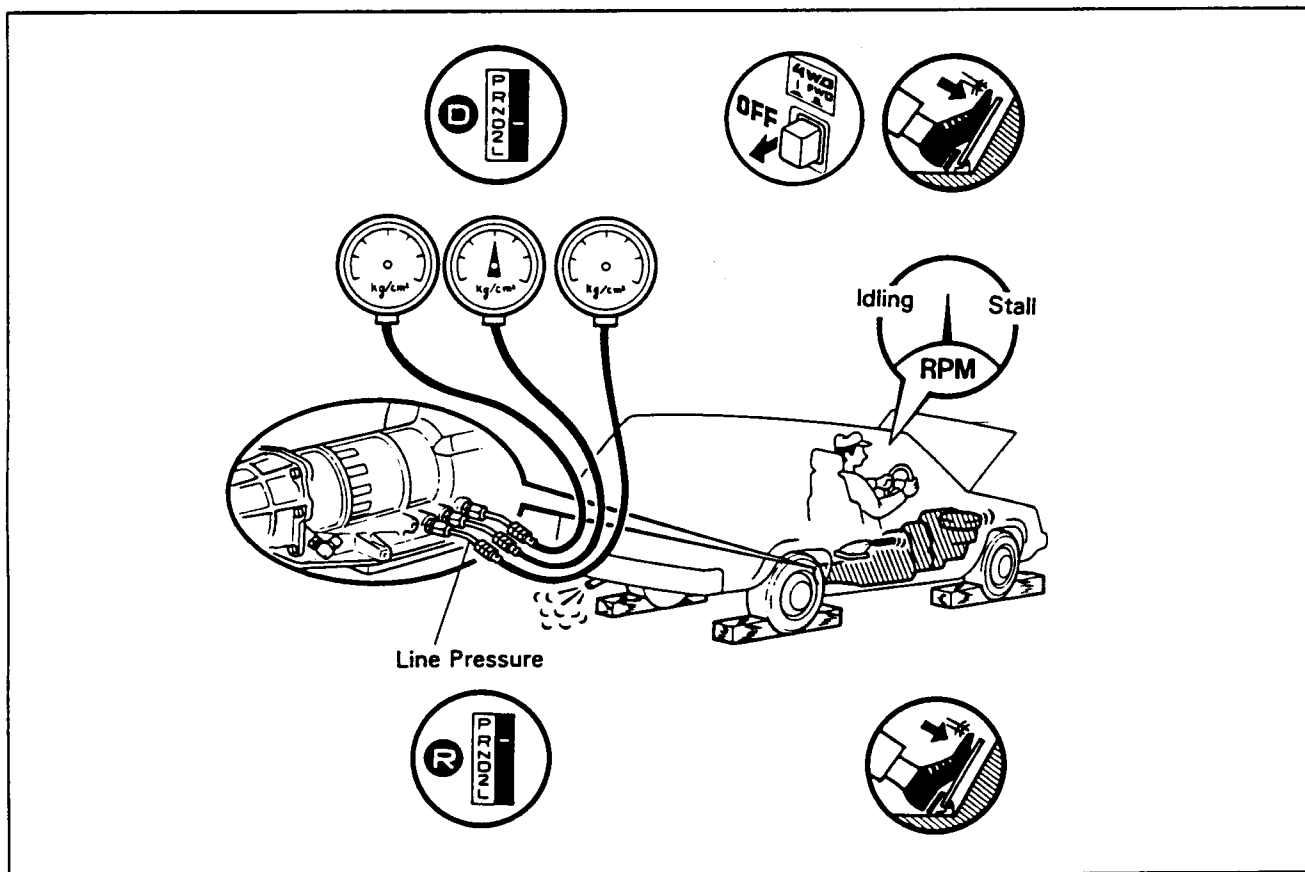

MEASURE THROTTLE PRESSURE

- Fully apply the parking brake and chock the four wheels.
- Turn off the 4WD change-over switch.
- Start the engine and shift into "D" range.
- Step down strongly on the brake pedal and while manipulating the acceleration pedal with the right foot, measure the throttle pressure at the engine speeds specified in the table below.
- In the same manner, perform the test for "R" range.

Engine speed rpm	Throttle pressure kg/cm ² (psi, kPa)	
	"D", "R" range	
Idling	0 - 0.3	(0 - 4.3, 0 - 29)
Stall	7.7 - 8.3	(110 - 118, 755 - 814)

- If the measured pressures are not up to specified values, recheck the throttle link adjustment and retest.

EVALUATION

- If the measured values are higher than specified:
 - Throttle valve defective.
 - Throttle circuit orifice clogged
- If the measured values are lower than specified:
 - Throttle valve defective
 - Regulator valve defective
 - Oil pump defective

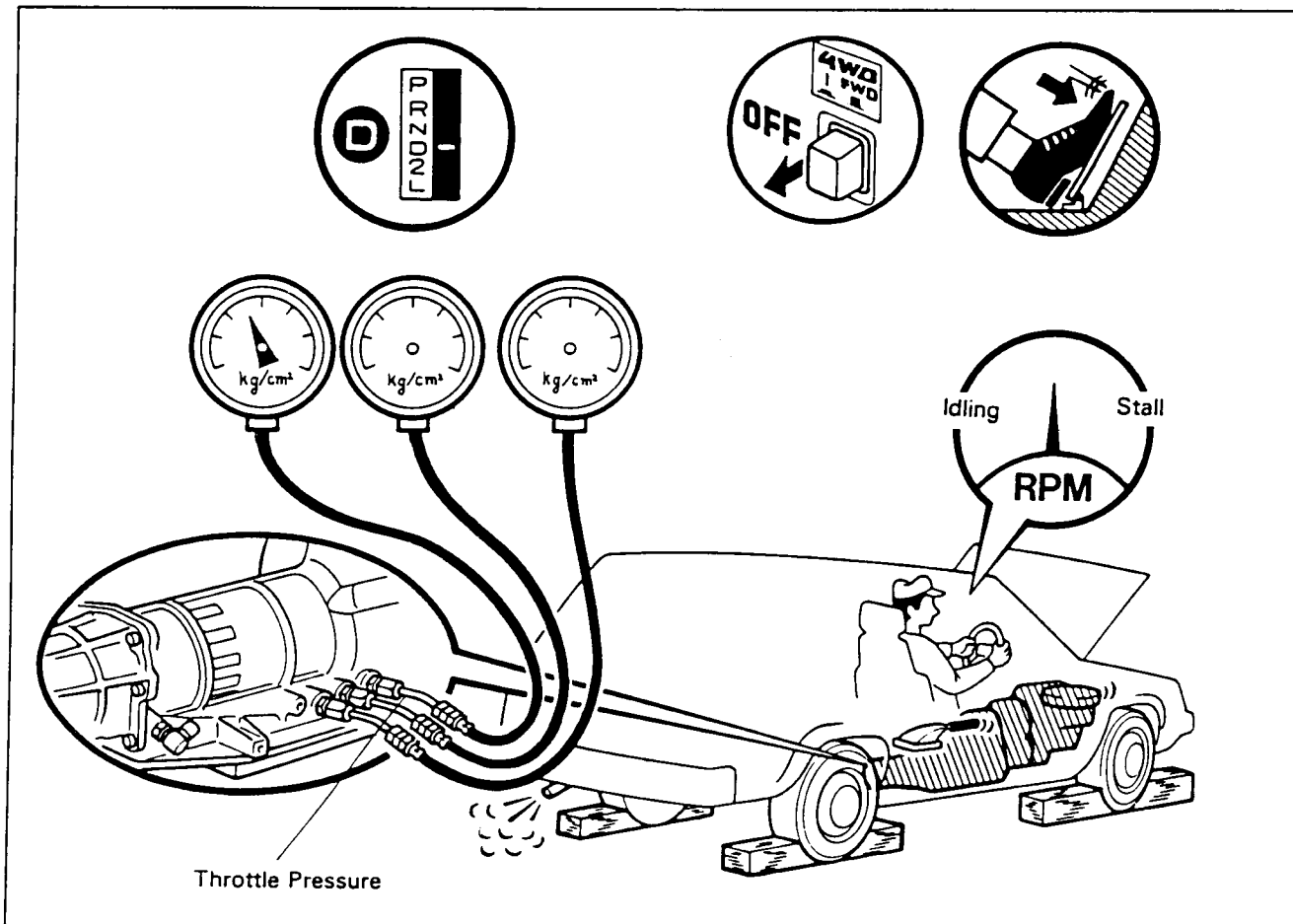



AUTOMATIC SHIFT DIAGRAM

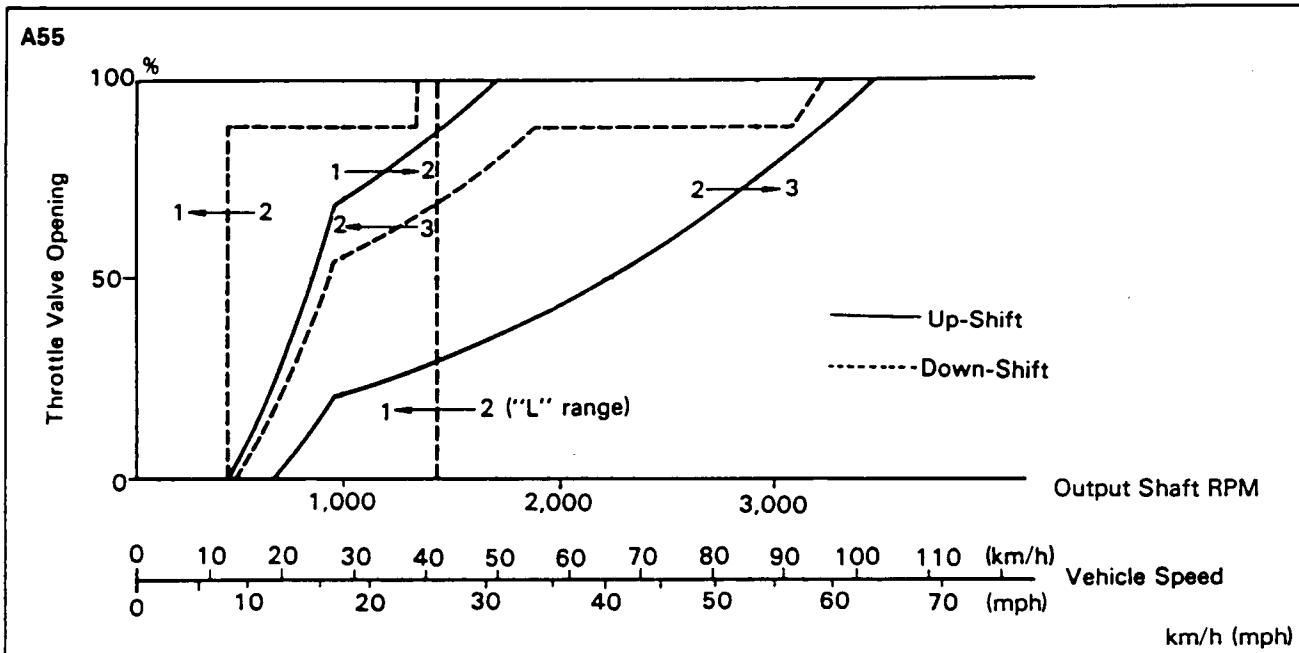

Differential gear ratio	"D" range (throttle valve fully open)				"L" range
	1 → 2	2 → 3	3 → 2	2 → 1	2 → 1
A55 3.583	42 - 58 (26 - 36)	96 - 110 (60 - 68)	88 - 103 (55 - 64)	33 - 49 (21 - 30)	35 - 51 (22 - 32)

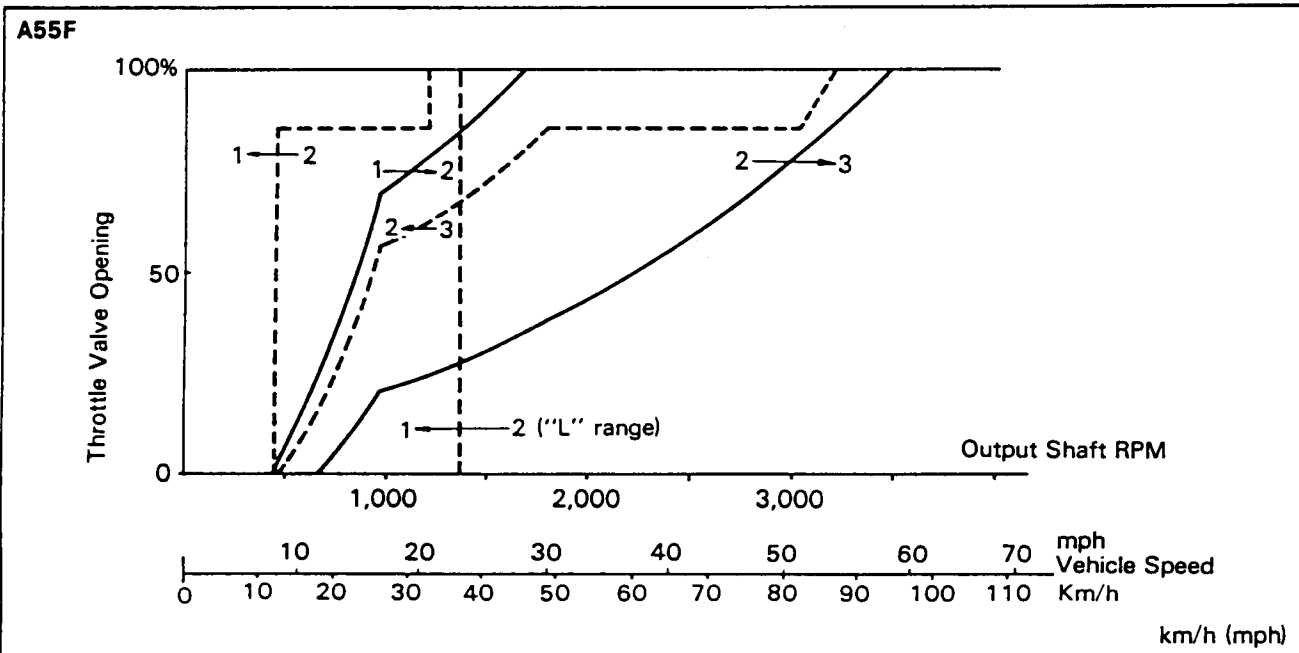

Differential gear ratio	"D" range (throttle valve fully open)				"L" range
	1 → 2	2 → 3	3 → 2	2 → 1	2 → 1
A55F 3.909	37 - 53 (23 - 33)	86 - 101 (53 - 63)	81 - 96 (50 - 60)	32 - 48 (20 - 30)	29 - 45 (18 - 28)



ELECTRIC CONTROL CIRCUIT

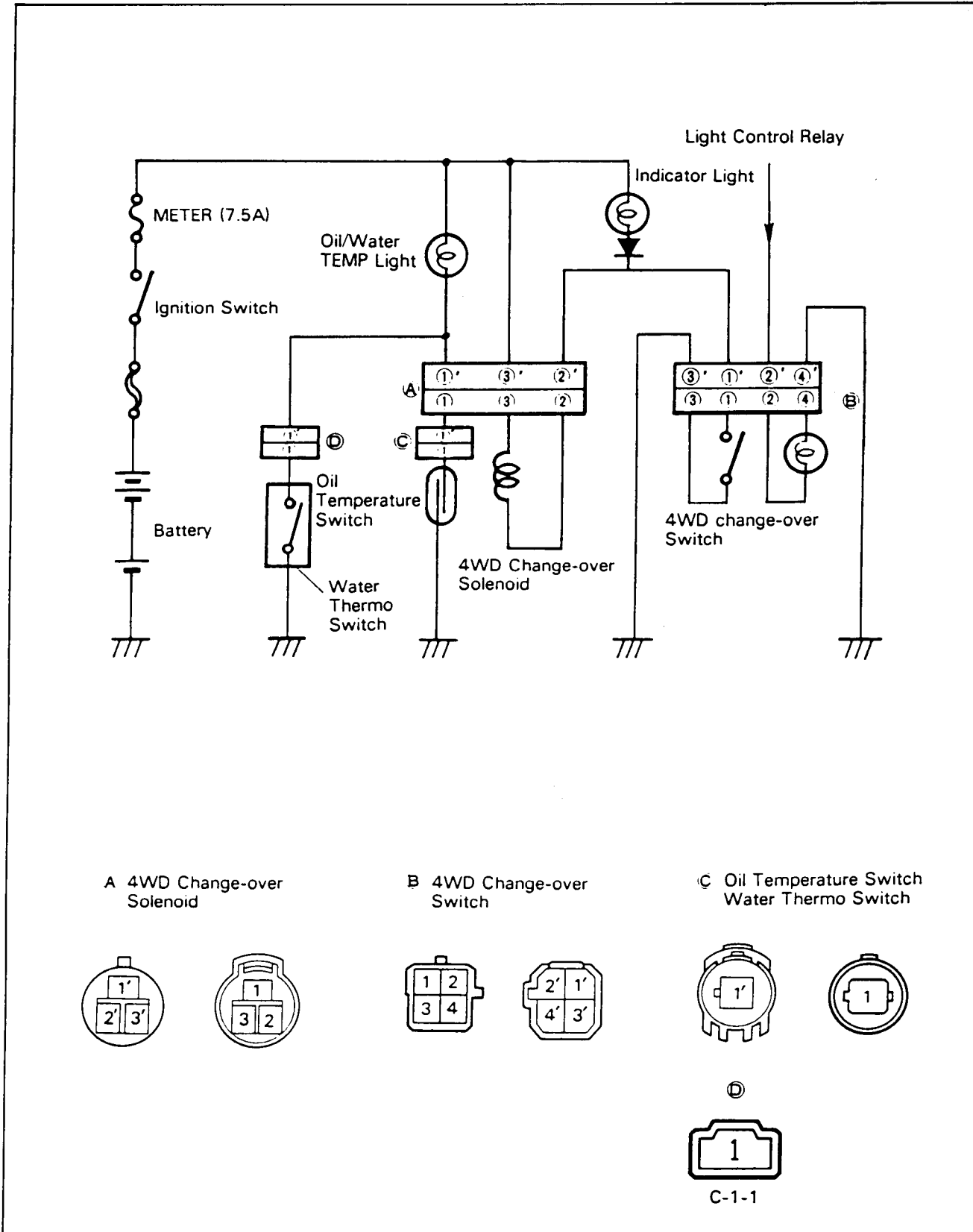

INSPECTION OF ELECTRIC CONTROL COMPONENTS

INSPECT FOUR-WHEEL DRIVE CHANGE-OVER ELECTRIC SYSTEM

- (a) Turn on the ignition switch.
 - (b) Turn on the 4WD change-over switch.
 - (c) At this time confirm that there is an operation sound from the 4WD change-over solenoid.
- If there is no sound, check the 4WD change-over switch, solenoid and circuit.

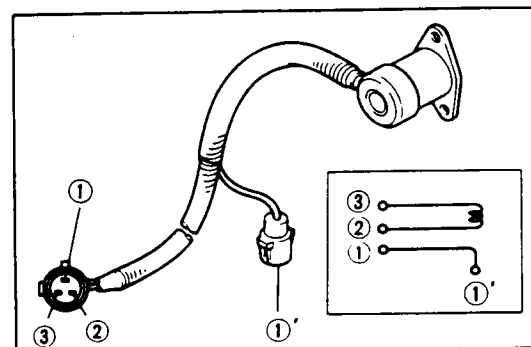
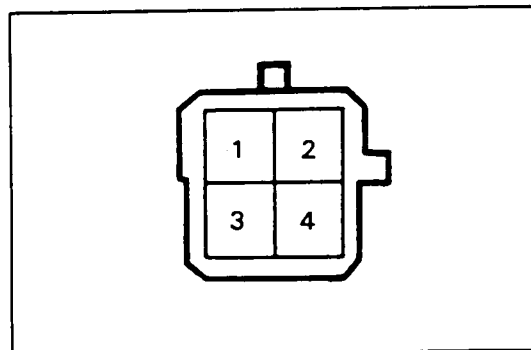
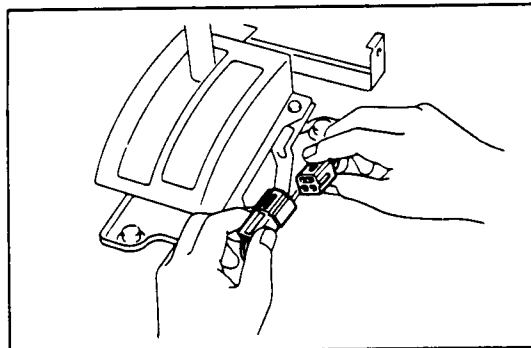
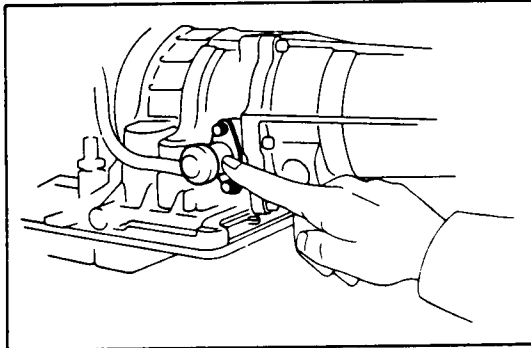
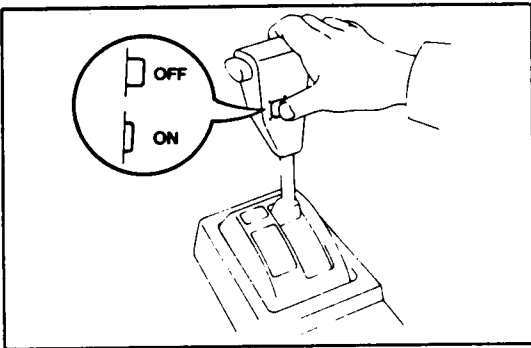

INSPECT FOUR-WHEEL DRIVE CHANGE-OVER SWITCH

- (a) Disconnect the 4WD change-over switch connector.
- (b) Using an ohmmeter, check the continuity of the terminals for each switch position.

Switch position \ Terminal	1	2	3	4
ON	○	○	○	○
OFF		○	○	○

- (c) Connect the 4WD change-over switch connector.

INSPECT FOUR-WHEEL DRIVE CHANGE-OVER SOLENOID

- (a) Disconnect the solenoid connector. Using an ohmmeter, measure the solenoid coil resistance between terminal 2 and 3.

Resistance: 13 Ω

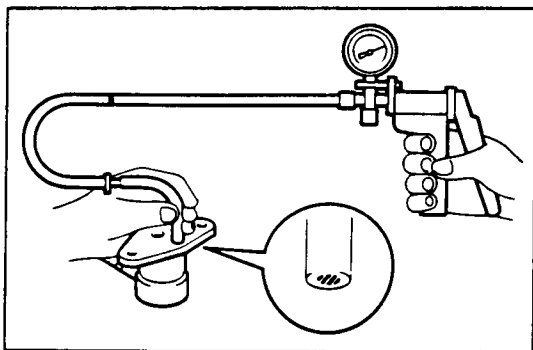

- (b) Connect the battery positive (+) lead to terminal 3 and the negative lead to terminal 2, and check for a solenoid operation sound.
- (c) Remove the solenoid valve and place a Mighty-Vac hose over solenoid valve hole. Apply vacuum and check for leaks.
- (d) Install the solenoid.

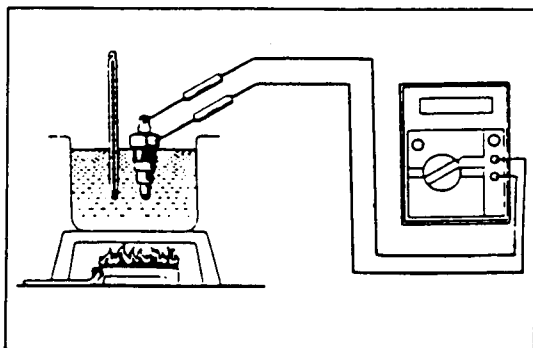

INSPECT WATER THERMO SWITCH

- (a) Remove the water thermo switch.
- (b) Using an ohmmeter, measure the resistance between the terminal and ground.

Coolant temperature	Resistance (Ω)
Below 103°C (217°F)	∞
Above 110°C (230°F)	6.6 – 9.8

- (c) Install the thermo switch.

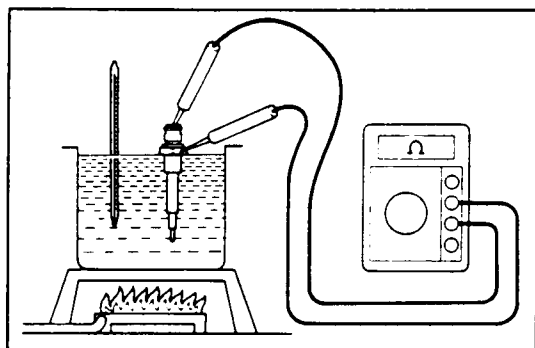

INSPECT OIL TEMPERATURE SWITCH

- (a) Remove the oil temperature switch.
- (b) Using an ohmmeter, measure the resistance between the terminal and ground.

Oil tempreture	Resistance (Ω)
Below 125°C (257°F)	∞
Above 132°C (270°F)	6.6 – 9.8

- (c) Install the oil temperature switch.



Technical Service Information

TROUBLESHOOTING OF ELECTRIC CONTROL

Trouble 1. No 4WD change-over

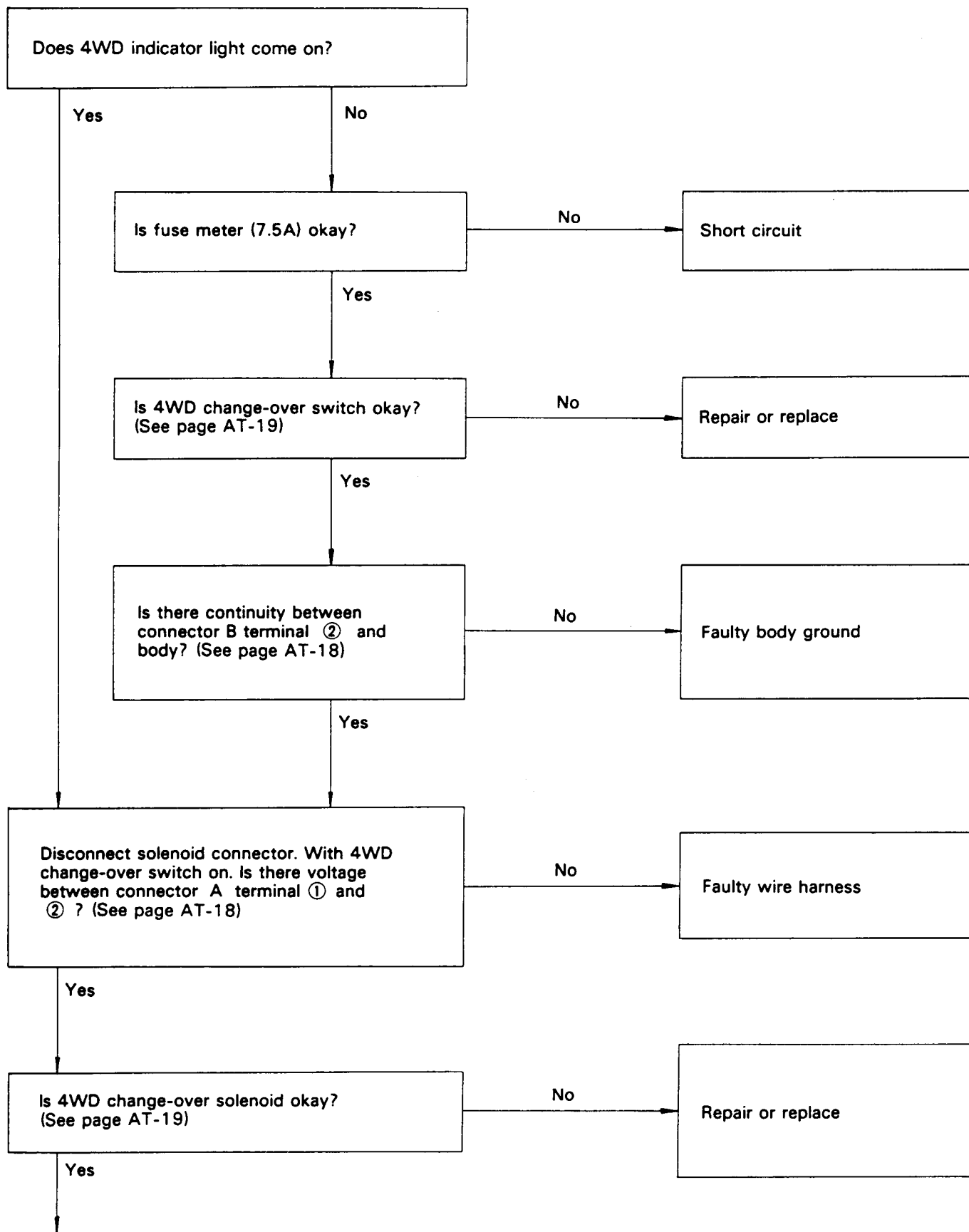

Continued on page



Technical Service Information

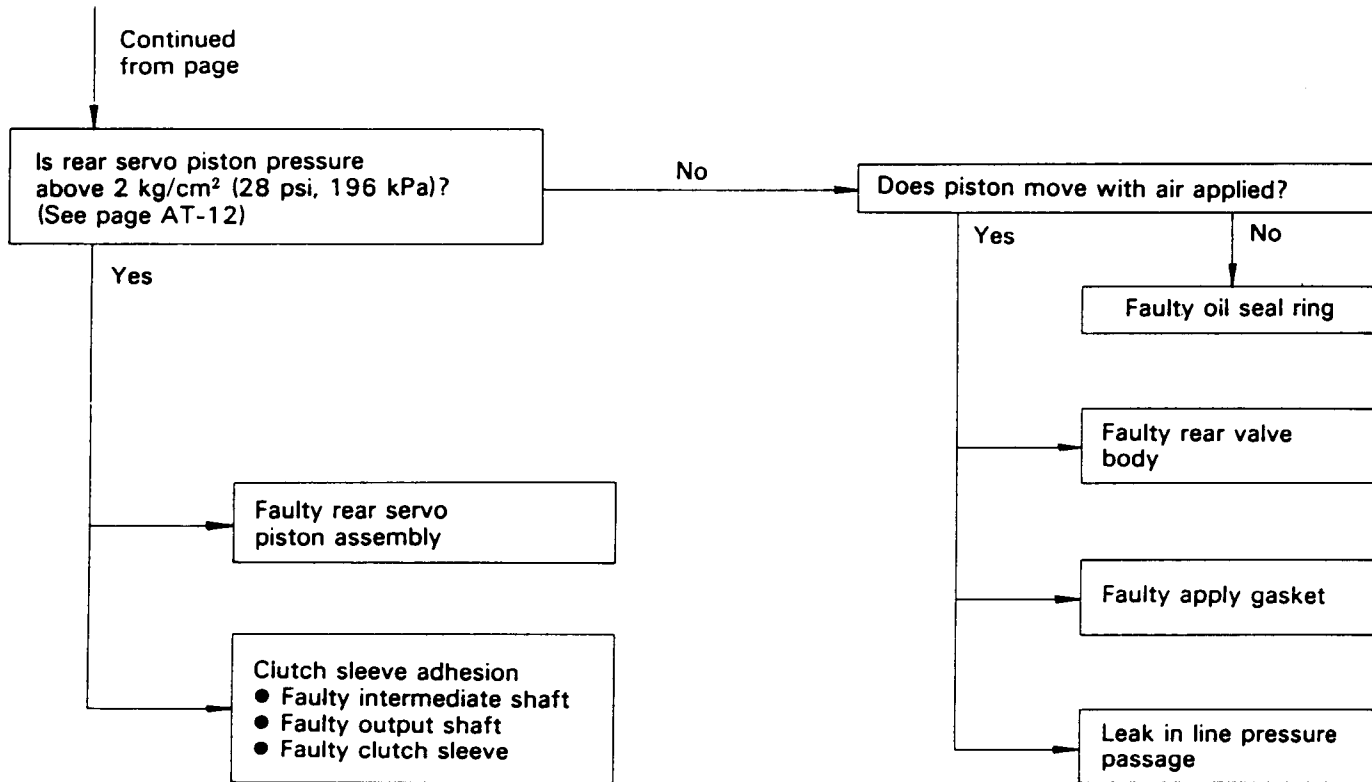



Technical Service Information

Trouble 2. No return to front-wheel drive

NOTE: During acceleration, etc. when drive force is applied to the drive axis, there will be no immediate change-over to front-wheel drive even when the switch is turned off.

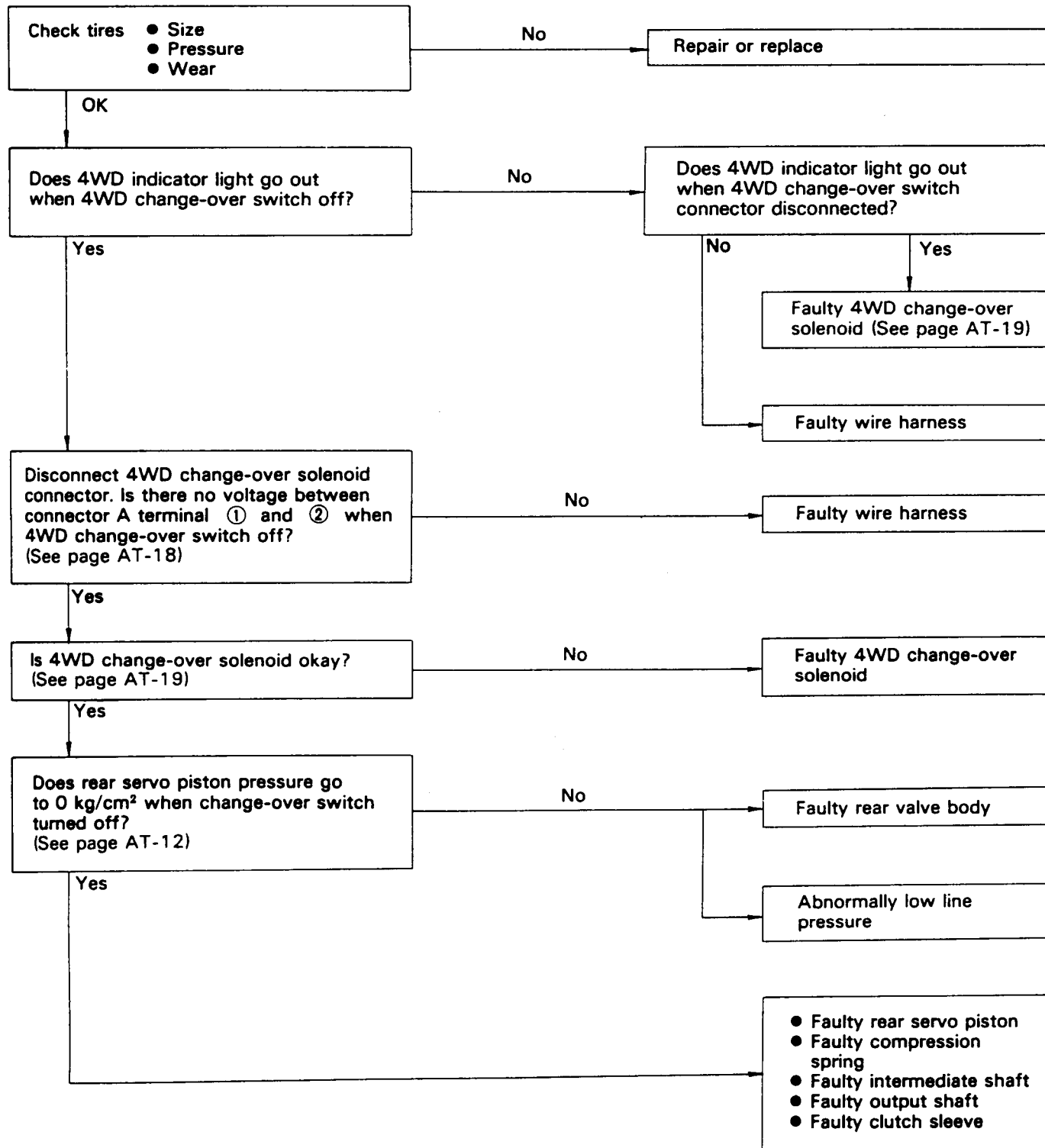

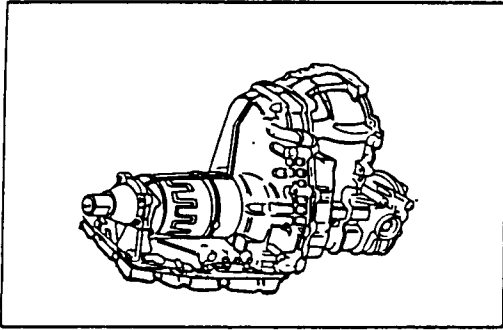

DISASSEMBLY OF TRANSMISSION SEPARATE BASIC SUBASSEMBLY

REMOVE TRANSMISSION FROM TRANSAXLE

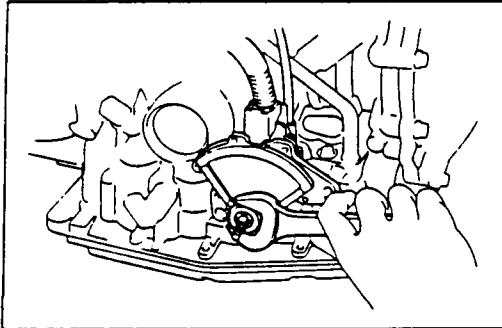

REMOVE NEUTRAL START SWITCH

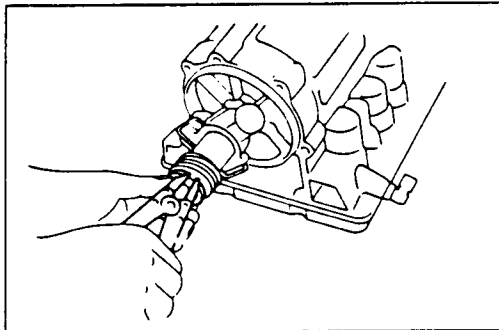

REMOVE SPEEDOMETER DRIVEN GEAR HOUSING

REMOVE EXTENSION HOUSING AND GASKET

REMOVE SPEEDOMETER DRIVE GEAR

REMOVE OUTPUT SHAFT SLEEVE

NOTE: Be careful not to lose the locking balls.

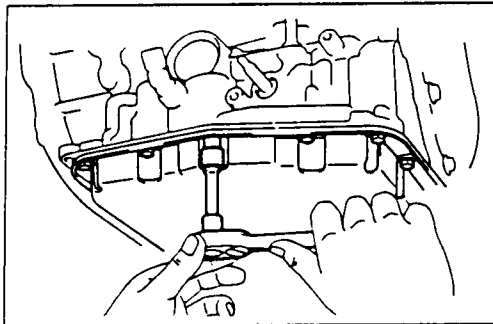

REMOVE PAN AND GASKET

CAUTION: Do not turn the transmission over as this will contaminate the valve body with foreign materials in the bottom of the pan.

(a) Remove the seventeen bolts.

(b) Remove the pan from the transmission case.

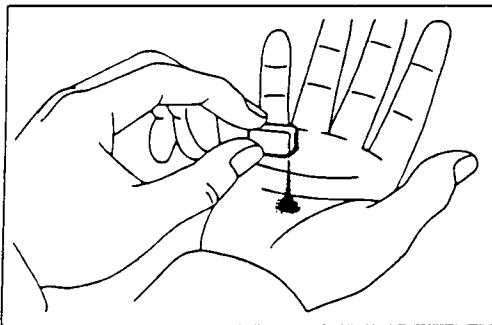

EXAMINE PARTICLES IN PAN

Remove the magnet and use it to collect any steel chips. Look carefully at the chips and particles in the pan and on the magnet to anticipate what type of wear you will find in the transmission:

Steel (magnetic) = bearing, gear and clutch plate wear.

Brass (nonmagnetic) = bushing wear.

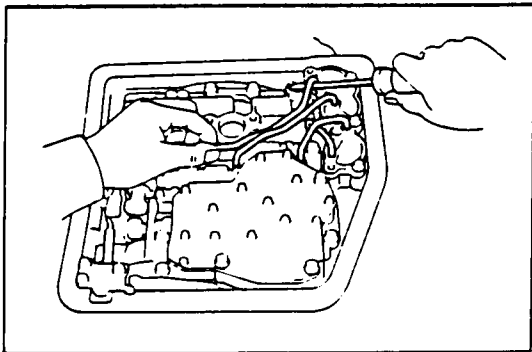
**TURN TRANSMISSION OVER AND REMOVE TUBES**

Pry up both tube ends with a large screwdriver and remove the tubes.

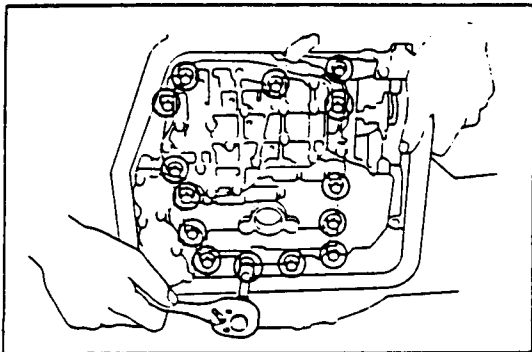
**REMOVE STRAINER****REMOVE VALVE BODY**

(a) Remove the fourteen bolts.

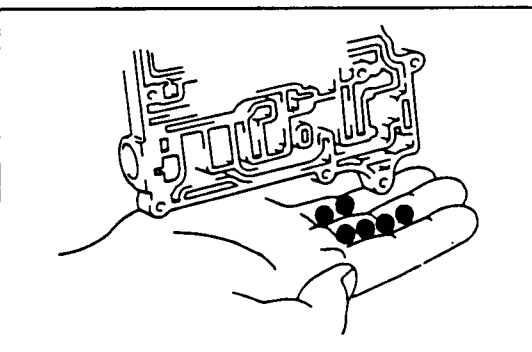

(b) Remove the six steel balls.

(c) Remove the valve vibrating stopper.

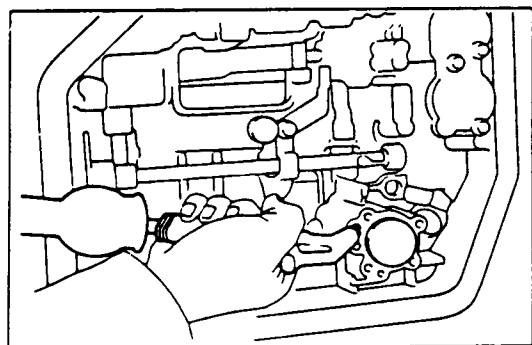
**REMOVE ACCUMULATOR PISTONS AND SPRINGS**

WARNING: Keep face away to avoid injury. Do not use regular high-pressure air.

Position a rag to catch each piston. Using low-pressure compressed air (1 kg/cm², 14 psi or 98 kPa max.) pop each piston into the rag. Force air into holes shown, and remove the pistons and springs.

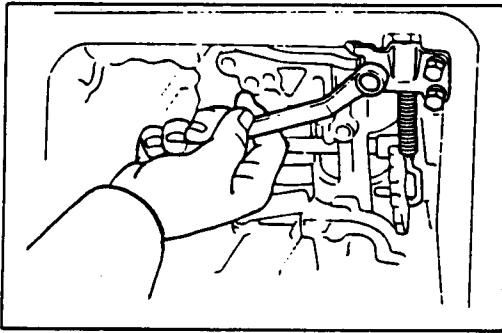

REMOVE PARKING LOCK ROD

REMOVE SPRING, PIVOT PIN AND PARKING LOCK PAWL

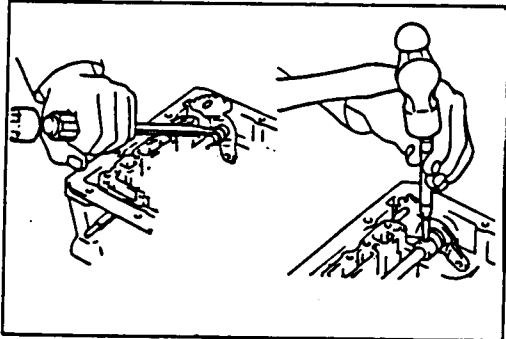

REMOVE SPACER

Unstake the spacer and turn the ring 90°.

DRIVE OUT SLOTTED SPRING PIN AND REMOVE MANUAL VALVE LEVER SHAFT

Using a hammer and punch, drive out the slotted spring pin.

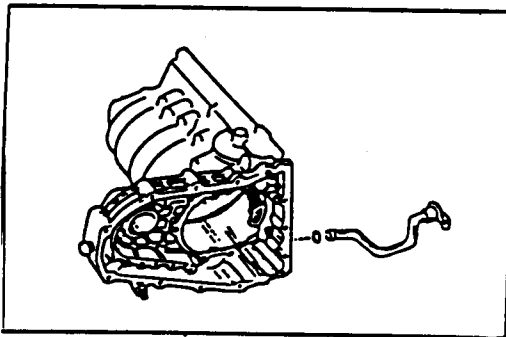

REMOVE OIL PUMP SUCTION TUBE

After removing the bracket bolt, remove the pump suction tube.

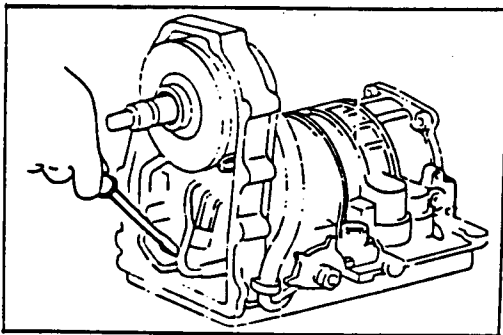

REMOVE OIL PUMP DELIVERY TUBE AND PRESSURE TUBE

Pry up both tube ends with a large screwdriver and remove the tubes.

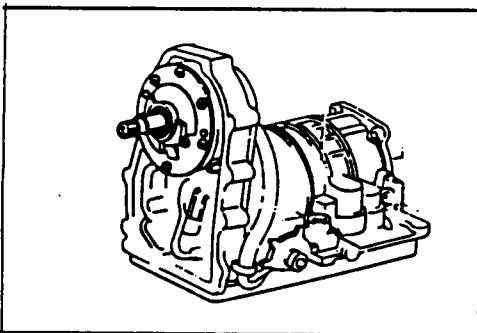

REMOVE OIL PUMP

(a) Loosen the three bolts, but do not remove them.

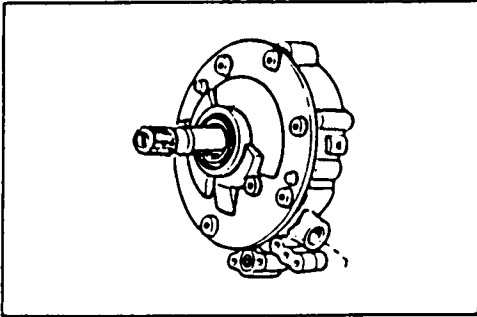

- (b) Remove the seven bolts and pull out the oil pump.

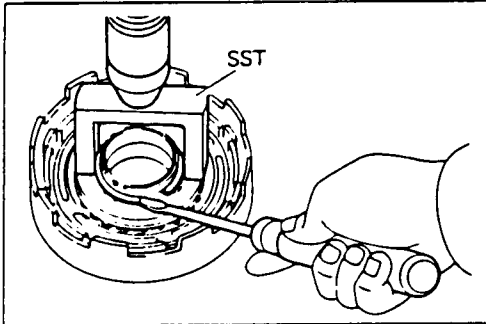

REMOVE INPUT SHAFT, DRIVEN SPROCKET AND CHAIN

- (a) Remove the snap ring.
 (b) Remove both sprockets, pulling them out uniformly.

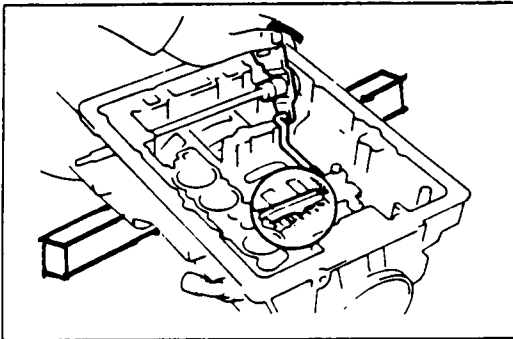

PLACE TRANSMISSION CASE ON WOODEN BLOCK AND REMOVE FRONT SUPPORT

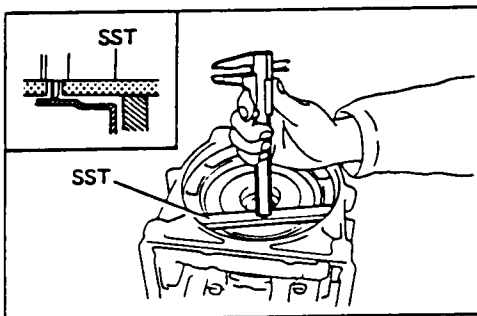

22. MEASURE DISTANCE BETWEEN TOP OF CASE AND FRONT CLUTCH

Make a note of the distance for reassembly.

SST 09350-20013

Height: 0.6 – 1.6 mm (0.024 – 0.063 in.)

REMOVE FRONT CLUTCH AND BEARINGS

Grasp the shaft and pull out the front clutch assembly. Be careful of bearings and races on both sides of the assembly.

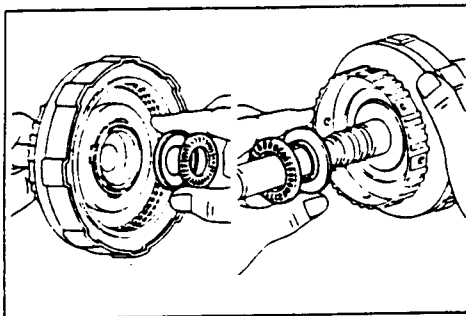



Technical Service Information

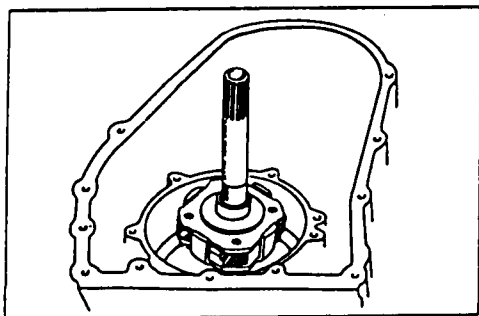

REMOVE OUTPUT SHAFT AND FRONT PLANETARY GEAR

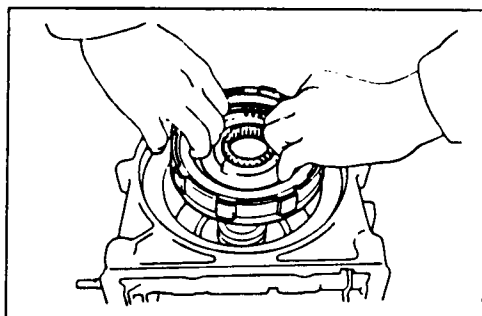

REMOVE REAR CLUTCH

Grasp the clutch hub and pull it out from the case.

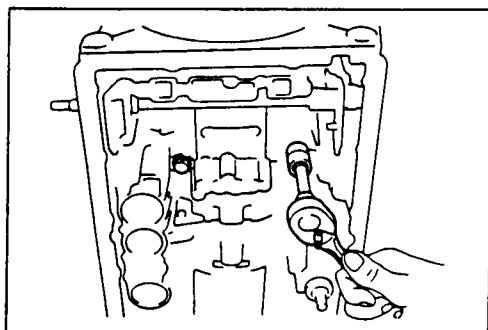

REMOVE CENTER SUPPORT BOLTS

Remove the two center support bolts.

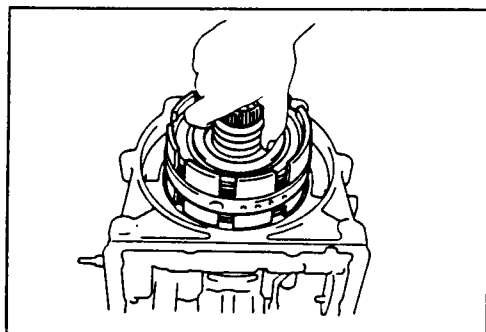

REMOVE CENTER SUPPORT AND SUN GEAR ASSEMBLY

From the case front opening, grasp the assembly and pull it out.

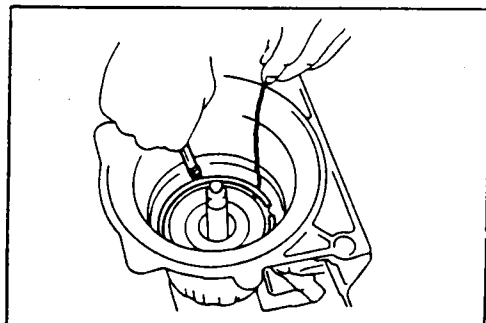

REMOVE REACTION PLATE RETAINING RING

Using a long screwdriver, compress the snap ring and lift it above the groove with a wire hook.

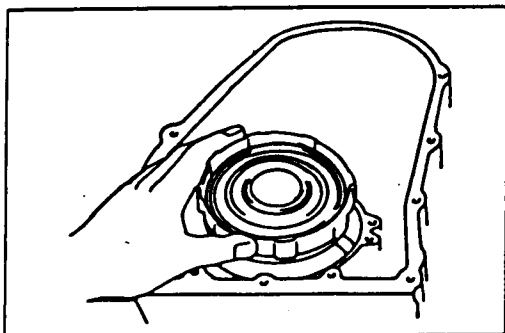

REMOVE REAR NO. 2 ONE-WAY CLUTCH AND REAR PLANETARY GEAR

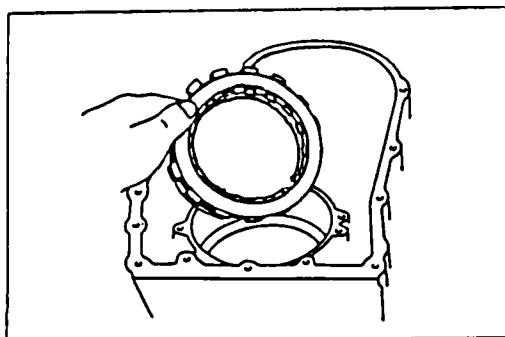

REMOVE BRAKE NO. 3 DISC, PLATE AND CUSHION PLATE

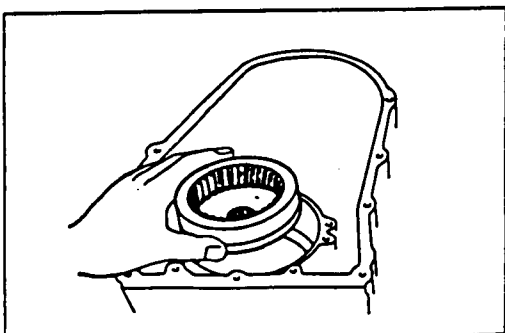

REMOVE REAR PLANETARY RING GEAR

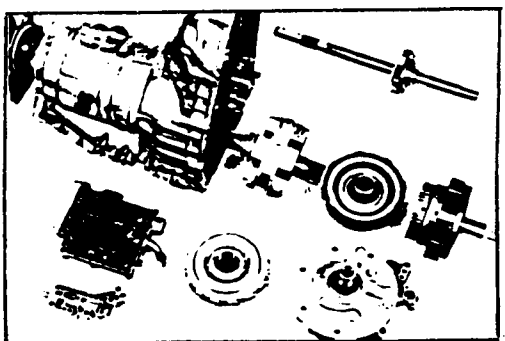

BASIC DISASSEMBLY IS COMPLETE

The transmission is now in basic component subassemblies. Next, you will disassemble, clean, inspect, repair and assemble each of these component groups.



COMPONENT GROUP DISASSEMBLY, INSPECTION AND ASSEMBLY

The instructions here are organized so that you work on only one component group at a time. This will help avoid confusion of similar-looking parts from different subassemblies being on your workbench at the same time. The component groups are inspected and repaired from the bell housing side.

As much as possible, complete the inspection, repair, assembly before proceeding to the next component group. If a component group cannot be assembled because parts are being ordered, be sure to keep all parts of that group in a separate container while proceeding with disassembly, inspection, repair and assembly of other component groups.

GENERAL CLEANING

1. All disassembled parts should be washed clean and the fluid passages and holes blown through with compressed air to make sure that they are not clogged.
2. Use a recommended automatic transmission fluid or kerosene for cleaning solvent.
3. When using compressed air to dry parts, keep face away to avoid spraying ATF or kerosene in your face.

NOTE: However, do not use kerosene to clean rubber parts or gaskets.

PARTS ARRANGEMENT

1. After cleaning, the parts should be arranged in proper order to allow performing the inspection, repairs, and reassembly with efficiency.
2. When disassembling a valve body, be sure to keep each valve together with its corresponding spring.
3. New brakes and clutches that are to be used for replacement must be soaked in transmission fluid for at least two hours before assembly.

GENERAL ASSEMBLY

1. All oil seal rings, clutch discs, clutch plates, rotating parts, and sliding surfaces should be coated with transmission fluid prior to reassembly.
2. All gaskets and rubber O-rings should be replaced.
3. Make sure that the ends of a snap ring are not aligned with one of the cutouts and are installed in the groove correctly.
4. If a worn bushing is to be replaced, the replacement must be made with the subassembly containing that bushing.
5. Check thrust bearings and races for wear or damage. Replace if necessary.
6. Use petroleum jelly to keep parts in their places.

Oil Pump and Front Support

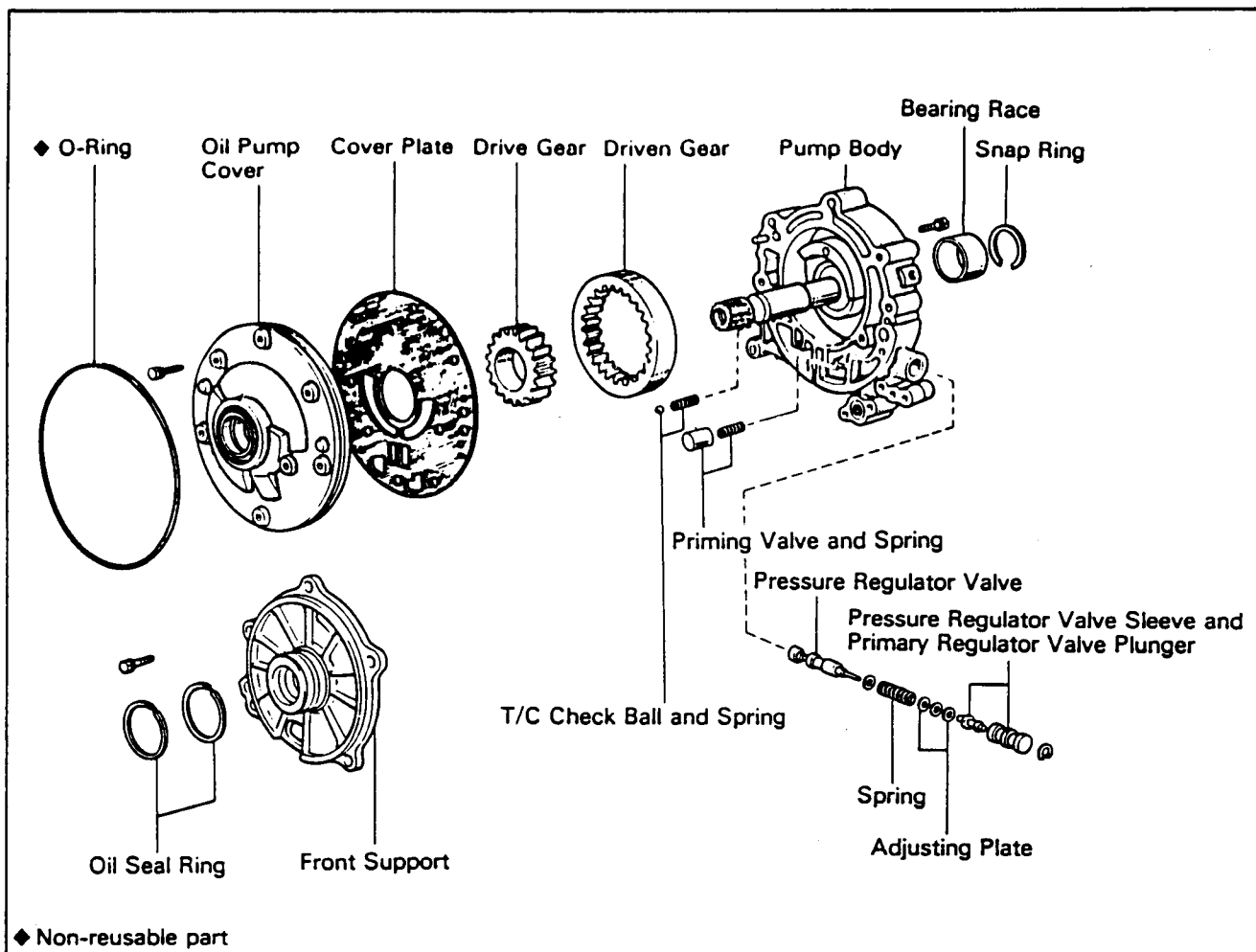

DISASSEMBLY OF OIL PUMP

REMOVE PUMP COVER

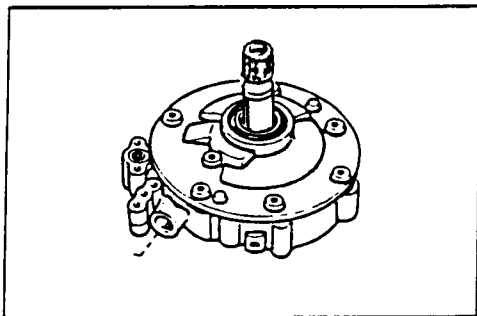

REMOVE CHECK BALL, PRIMING VALVE AND SPRING

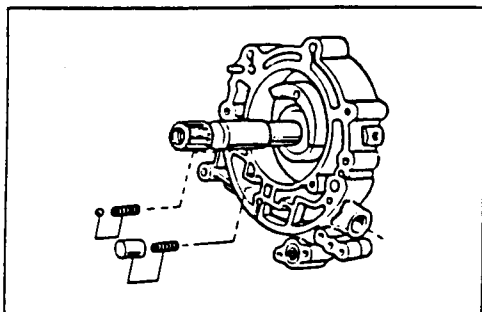



Technical Service Information

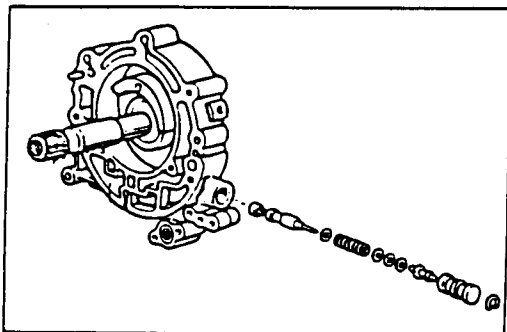

REMOVE PRESSURE REGULATOR VALVE ASSEMBLY

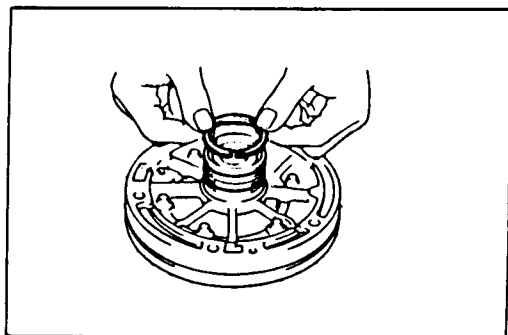

REMOVE TWO OIL SEAL RINGS FROM FRONT SUPPORT

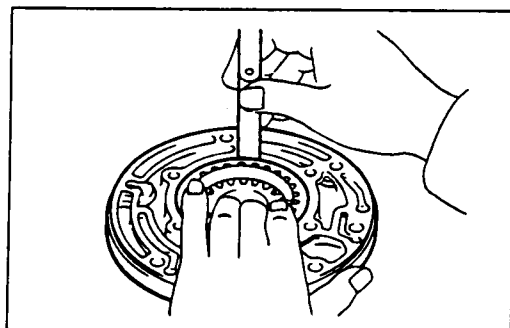

INSPECTION OF OIL PUMP

CHECK BODY CLEARANCE OF DRIVEN GEAR

Pull the driven gear to one side of the body. Using a feeler gauge, measure the clearance.

Standard body clearance: 0.07 – 0.15 mm
(0.0028 – 0.0059 in.)

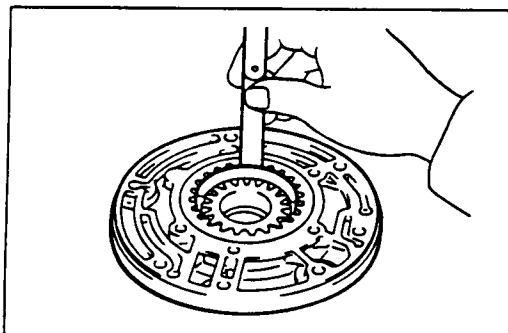

CHECK TIP CLEARANCE OF BOTH GEARS

Measure between the gear teeth and the crescent-shaped part of the pump body.

Standard tip clearance: 0.11 – 0.14 mm
(0.0043 – 0.0055 in.)

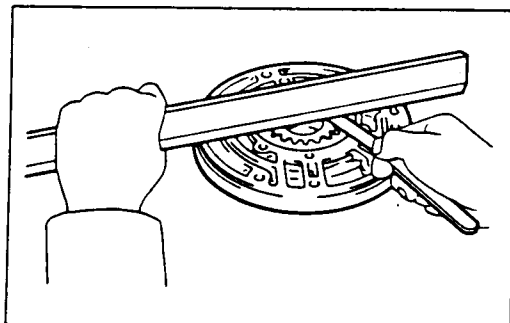

CHECK SIDE CLEARANCE OF BOTH GEARS

(a) Using a steel straightedge and a feeler gauge, measure the side clearance of both gears.

Standard side clearance: 0.02 – 0.05 mm
(0.0008 – 0.0020 in.)

(b) If not within specification, select and install the proper gears.

Mark	Gear width	mm (in.)
1	15.235 – 15.249	(0.5998 – 0.6004)
None	15.250 – 15.271	(0.6004 – 0.6012)
3	15.272 – 15.286	(0.6013 – 0.6018)

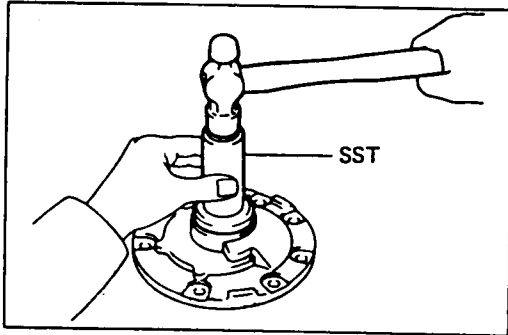

INSPECT FRONT OIL SEAL

Check for wear, damage or cracks.
If necessary, replace the oil seal as follows.

- (a) Pry off the oil seal with a screwdriver.
- (b) Using SST and hammer, install a new oil seal.
The seal end should be flush with the outer edge of the pump cover.

SST 09350-20013

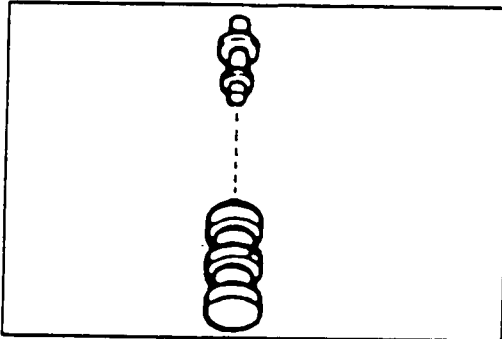

INSPECT OF REGULATOR VALVE AND PLUNGER

- (a) Pull out the plunger about half way and release it.
- (b) The plunger should sink down into the sleeve by its own weight.

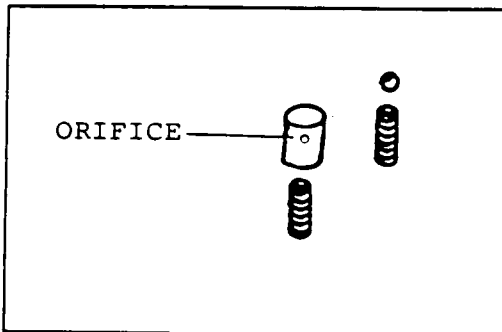

INSPECT OF PRIMING VALVE, CHECK BALL VALVE AND SPRING

Check for a clogged priming valve orifice.

	Free length mm (in.)
Check ball valve spring	26.20 (1.0315)
Priming valve spring	19.20 (0.7559)

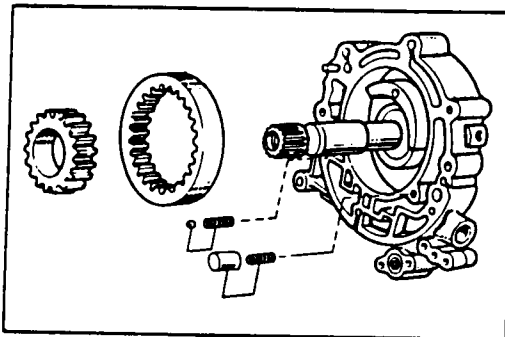

ASSEMBLY OF OIL PUMP

(See page AT-45)

INSTALL DRIVEN GEAR AND DRIVE GEAR

INSTALL PRIMING VALVE AND CHECK BALL VALVE

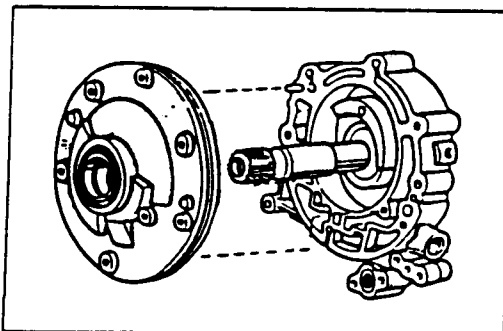

INSTALL OIL PUMP COVER

NOTE: Wrap the stator shaft spline with vinyl tape to protect the oil seal from damage.

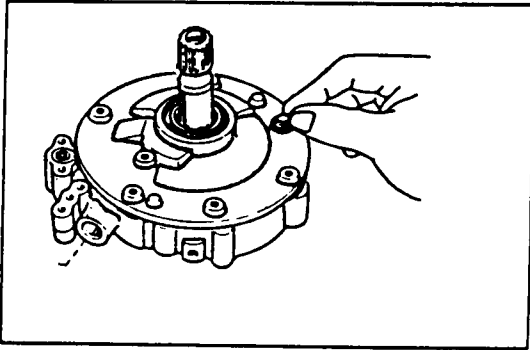

TEMPORARILY TIGHTEN PUMP COVER BOLTS

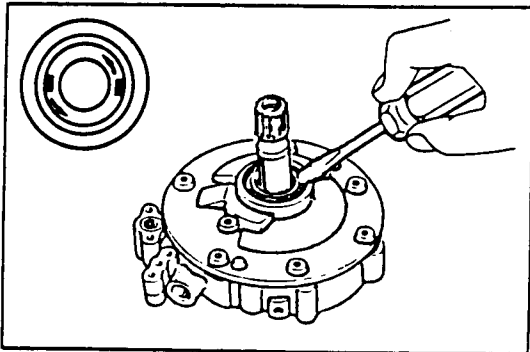

CHECK DRIVE GEAR ROTATION

Turn the drive gear with a screwdriver and make sure that it rotates smoothly.

NOTE: Be careful not to damage the oil seal.

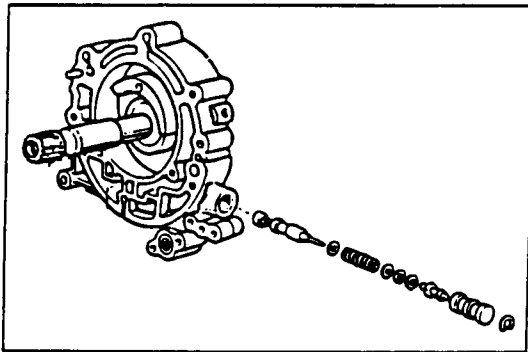

INSTALL PRESSURE REGULATOR VALVE ASSEMBLY

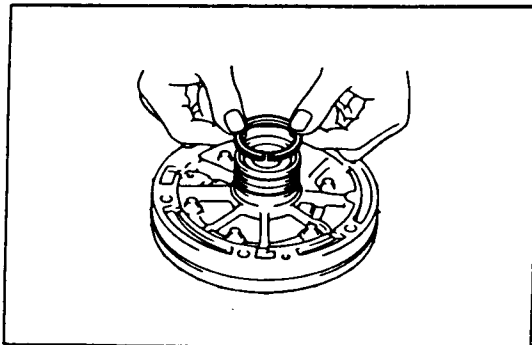

INSTALL TWO OIL SEAL RINGS ON FRONT SUPPORT

Spread apart and slide the rings into the groove.

Hook both ends by hand.

Wipe off any excess petroleum jelly.

INSTALL NEW O-RING ON PUMP

Make sure the O-ring is not twisted and is fully seated in the groove.

Front Clutch

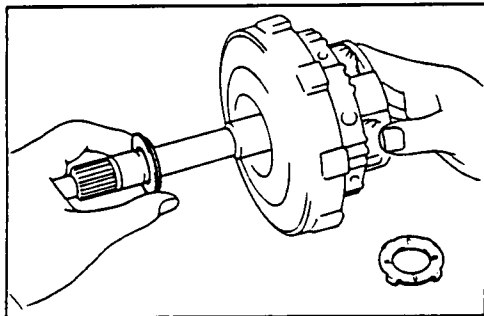
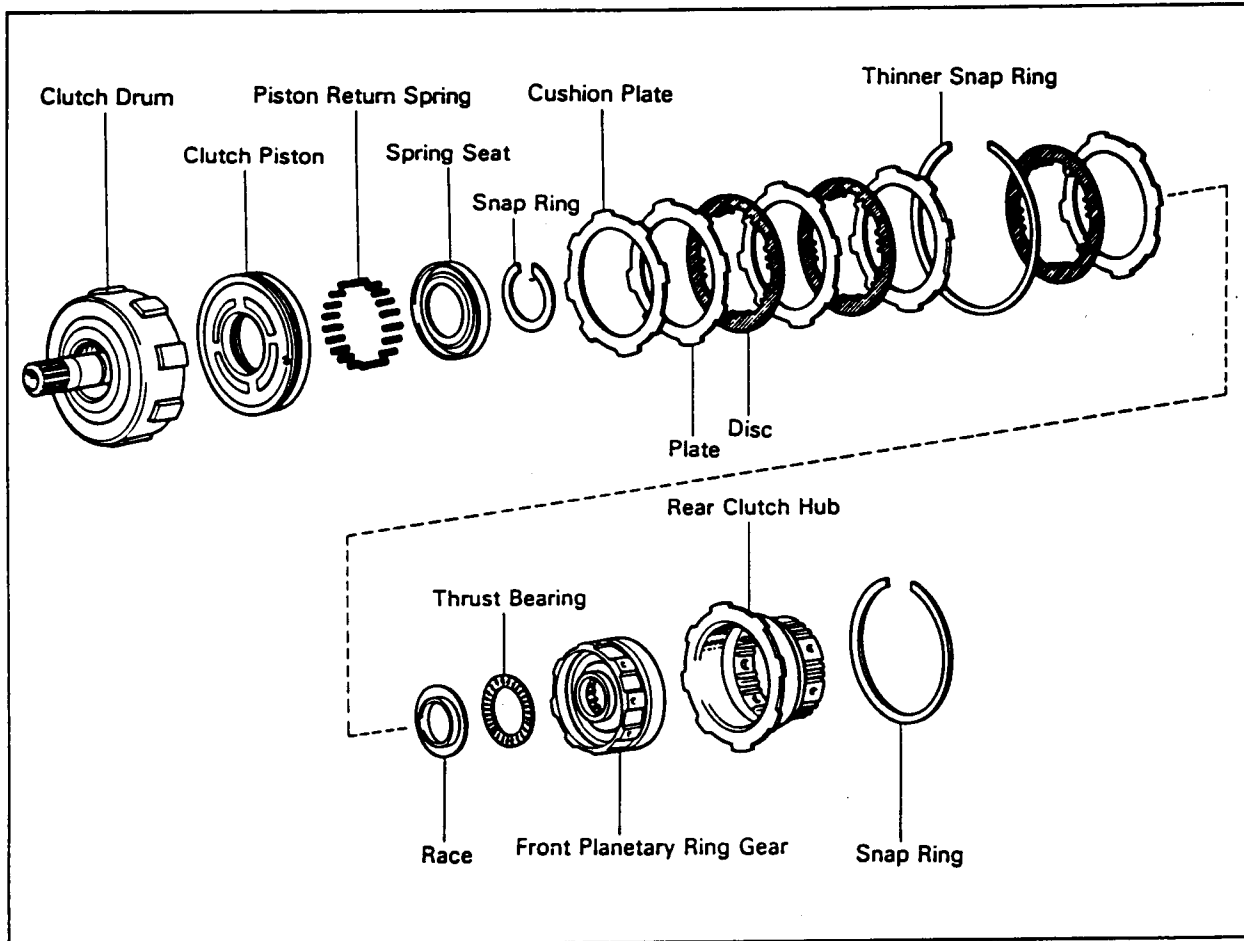

DISASSEMBLY OF FRONT CLUTCH

REMOVE THRUST BEARING AND RACE FROM FRONT SIDE OF CLUTCH

Note the position of the races.

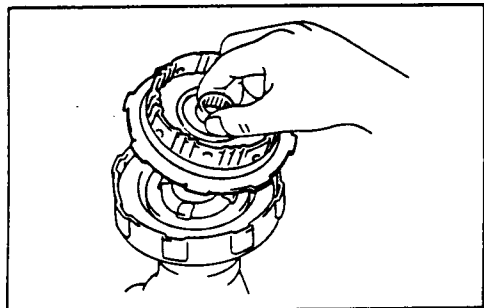

REMOVE SNAP RING FROM FRONT CLUTCH DRUM
REMOVE FRONT PLANETARY RING GEAR AND REAR CLUTCH HUB



Technical Service Information

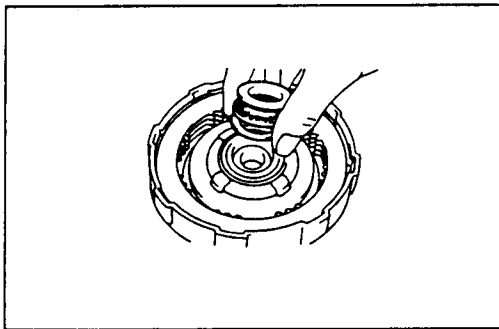

REMOVE THRUST BEARING AND RACES

Note the position of the races.

REMOVE CLUTCH PLATE AND DISC

REMOVE THINNER SNAP RING

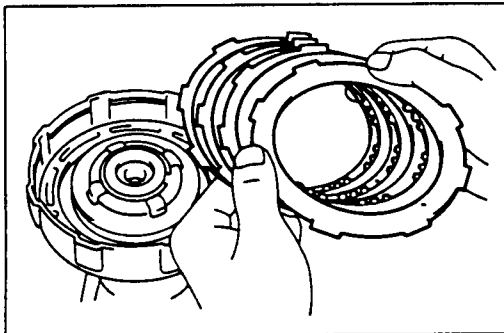

REMOVE REMAINING CLUTCH PLATES AND DISCS

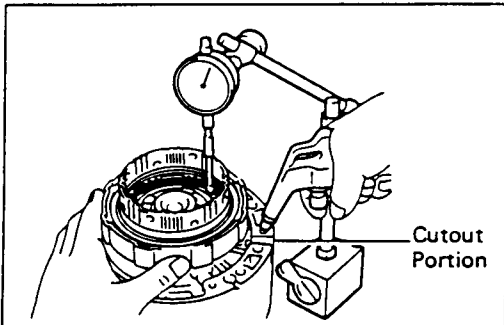

COMPRESS PISTON RETURN SPRINGS AND REMOVE SNAP RING

Place SST on the spring seat and compress the springs with a shop press.

Using a screwdriver, remove the snap ring.

SST 09350-20013

REMOVE SPRING SEAT AND TWENTY SPRINGS

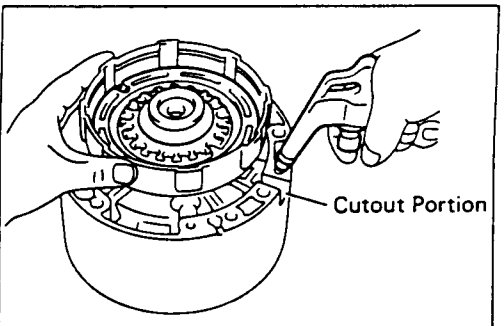

ASSEMBLE FRONT CLUTCH ON FRONT SUPPORT AND BLOW OUT PISTON

- Slide the front clutch onto the front support.
- Apply compressed air to the front support to remove the piston. If the piston does not come out completely, use pliers to remove it.
- Remove the front clutch from the front support.

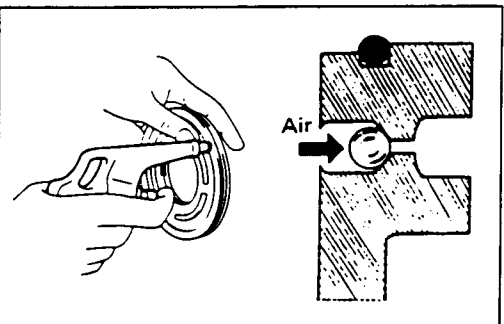

INSPECTION OF FRONT CLUTCH

INSPECT FRONT CLUTCH PISTON

- Check that check ball is free by shaking the piston.
- Check that valve does not leak by applying low-pressure compressed air.

INSPECT DISC, PLATE, RETURN SPRING AND CLUTCH DRUM

NOTE: Do not allow the discs to dry out.

Prepare new discs by soaking them at least two hours in ATF.

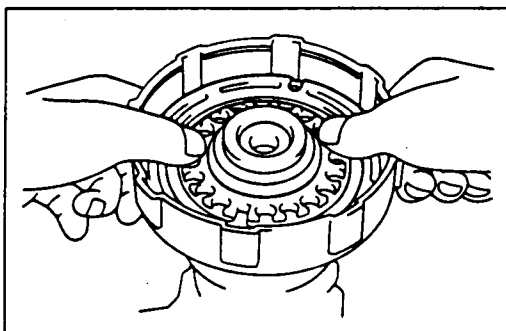
ASSEMBLY OF FRONT CLUTCH**INSTALL NEW O-RINGS ON PISTON****INSTALL PISTON IN FRONT CLUTCH DRUM**

Press into the housing with the cup side up (check ball down).

Be careful not to damage the O-rings.

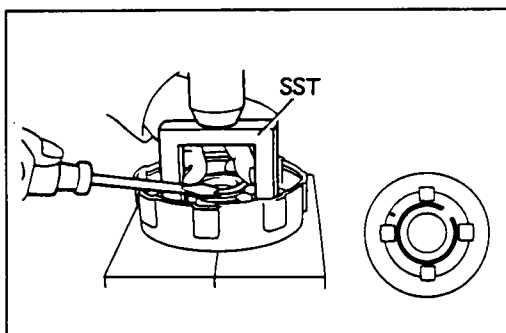
**INSTALL TWENTY PISTON RETURN SPRINGS,
SPRING SEAT AND SNAP RING IN PLACE****COMPRESS RETURN SPRINGS AND INSTALL SNAP
RING IN GROOVE**

(a) Place SST on the spring retainer, and compress the springs with a shop press.

SST 09350-20013

(b) Install the snap ring using a screwdriver.

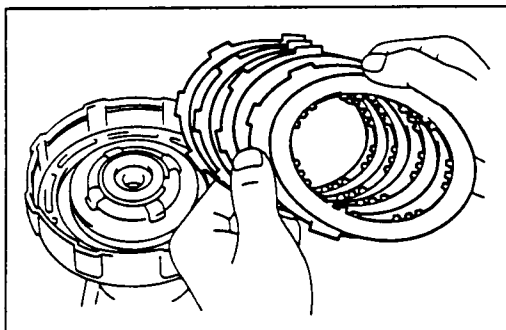
**INSTALL DISCS AND PLATES WITHOUT
ASSEMBLING THINNER SNAP RING**

Using low-pressure compressed air, (4 – 5 kg/cm², 57 – 71 psi or 392 – 490 kPa) blow all excess ATF from the discs. For measurement of the clutch pack, install all plates and discs (temporarily without the thinner snap ring).

In following order: Cushion plate-plate-disc-plate-disc-plate-dise-plate

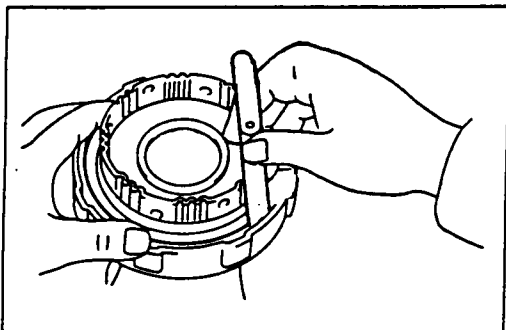
**MEASURE CLEARANCE OF FRONT CLUTCH**

Standard clearance: 0.30 – 1.49 mm
(0.0118 – 0.0587 in.)

NOTE: Measure completely around the circumference.

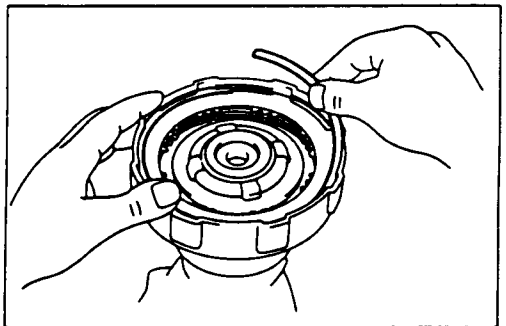
**INSTALL THINNER SNAP RING**

Remove the snap ring, rear clutch hub and one plate and disc to allow installation of the thinner snap ring.



Technical Service Information

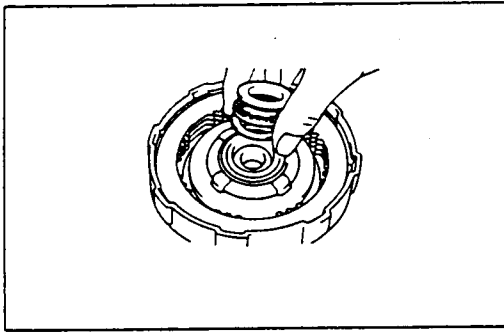

INSTALL INNER THRUST BEARING AND RACE

IMPORTANT: Coat the parts with petroleum jelly to keep them in place.

Install the inner race, and needle bearing. Press into place.

NOTE: Face the lip of the race toward the front clutch body.

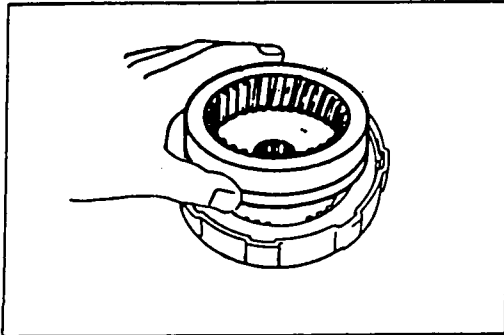

INSTALL PLANETARY RING GEAR

Align the disc lugs with the hub teeth. Make sure the hub meshes with all discs and is fully inserted.

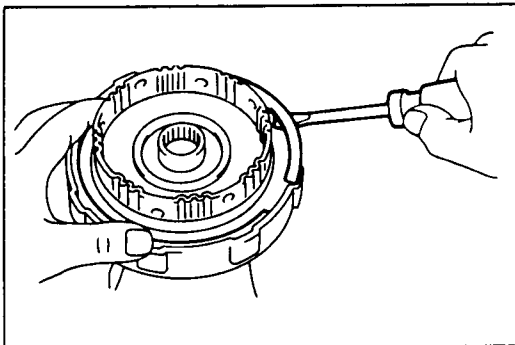

INSTALL REAR CLUTCH HUB AND OUTER SNAP RING

Check that the snap ring ends are not aligned with one of the cutouts.

Output Shaft and Front Planetary Gear

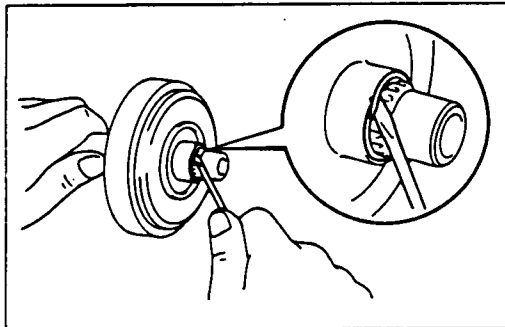
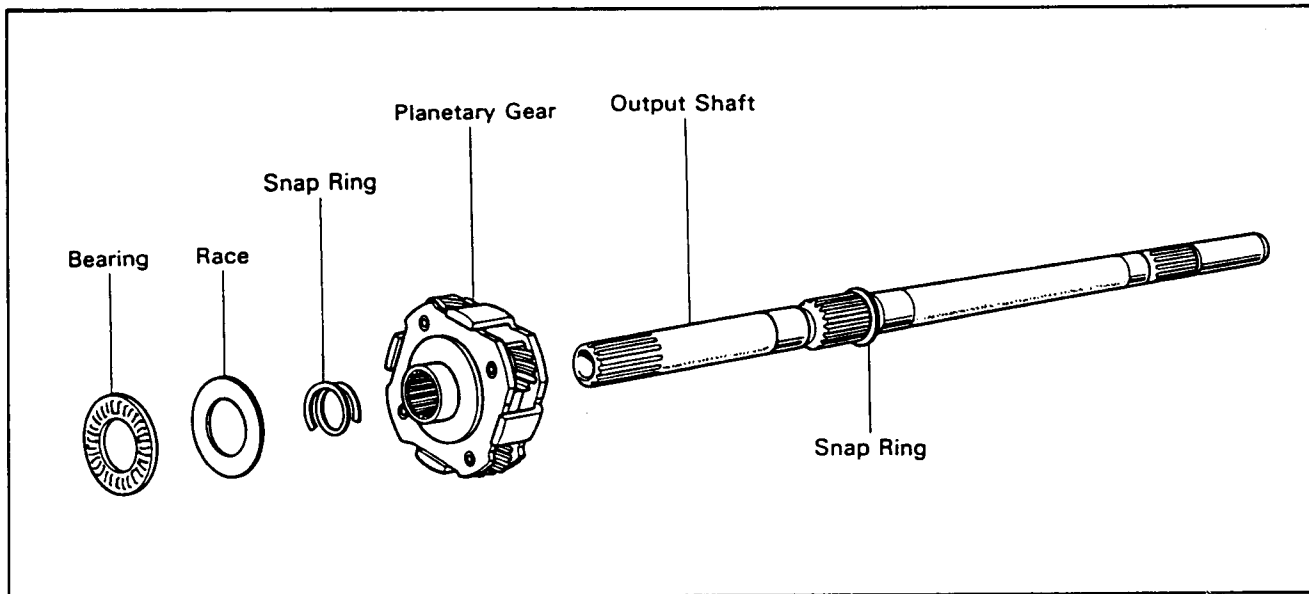

DISASSEMBLY OF OUTPUT SHAFT AND FRONT PLANETARY GEAR

REMOVE THRUST BEARING AND RACE FROM FRONT SIDE OF PLANETARY GEAR

REMOVE PLANETARY GEAR SNAP RING

Pull out the planetary gear from the output shaft.

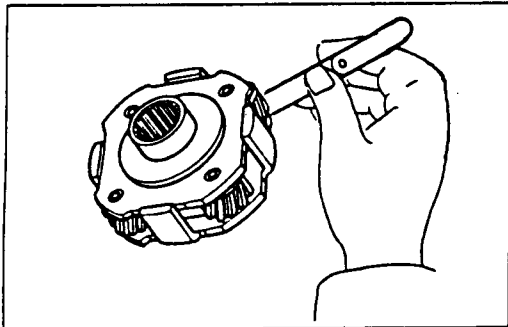

INSPECTION OF PLANETARY GEAR

MEASURE OF PLANETARY GEAR THRUST CLEARANCE

Standard clearance: 0.20 – 0.50 mm
(0.0079 – 0.0197 in.)

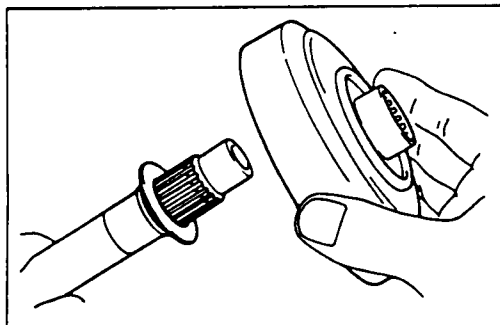

ASSEMBLY OF OUTPUT SHAFT AND FRONT PLANETARY GEAR

INSTALL PLANETARY GEAR SNAP RING

INSTALL THRUST BEARING AND RACE

Rear Clutch

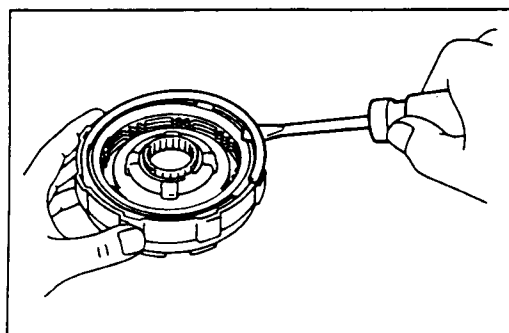
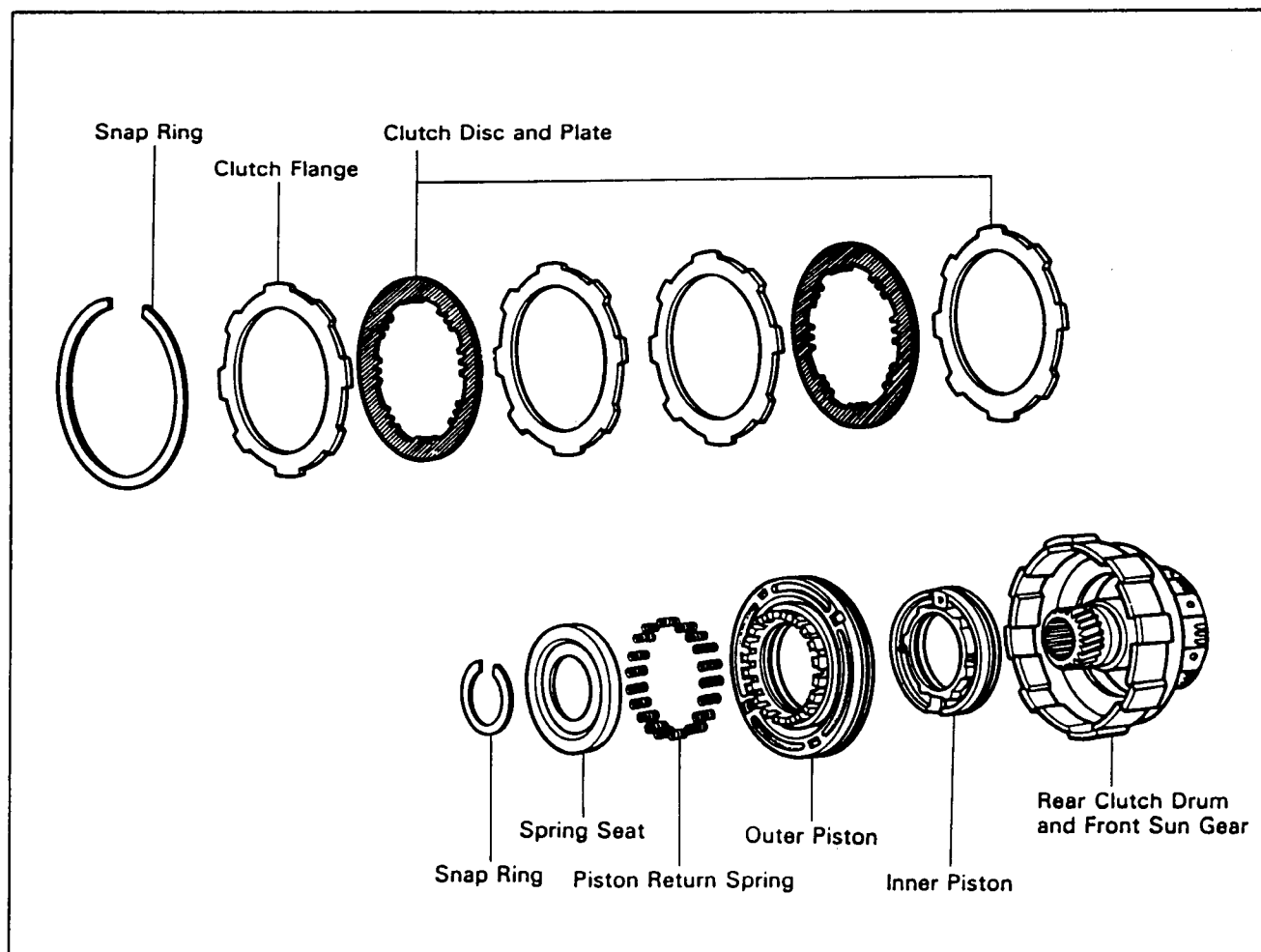

DISASSEMBLY OF REAR CLUTCH

REMOVE OUTER CLUTCH PACK RETAINING SNAP RING FROM DRUM

REMOVE CLUTCH FLANGE, DISCS AND PLATES

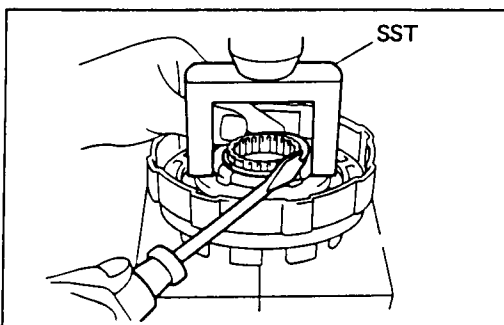

COMPRESS PISTON RETURN SPRINGS AND REMOVE SNAP RING

Place SST on the spring seat and compress the springs with a shop press.

Using a screwdriver, remove the snap ring.

SST 09350-20013

REMOVE SPRING SEAT, SNAP RING AND TWENTY RETURN SPRINGS

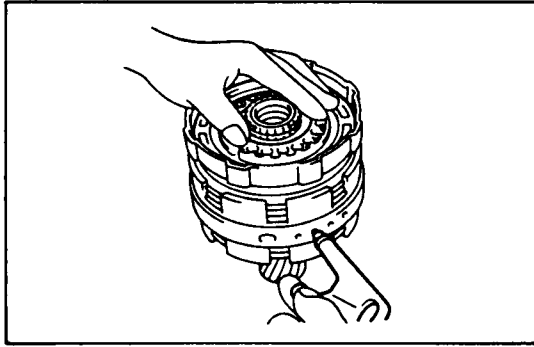
**ASSEMBLE REAR CLUTCH ON CENTER SUPPORT AND BLOW**

- (a) Slide the rear clutch onto the center support.
- (b) Apply compressed air to the center support to remove the piston. If the piston does not come out completely, use pliers to remove it.
- (c) Remove the rear clutch from the center support.

REMOVE O-RINGS FROM REAR CLUTCH PISTON**INSPECTION OF REAR CLUTCH****INSPECT REAR CLUTCH PISTON**

- (a) Check that the check ball is free by shaking each piston.
- (b) Check that the valve does not leak by applying low-pressure compressed air.

NOTE: Do not allow the discs to dry out. Prepare new discs by soaking them at least two hours in ATF.

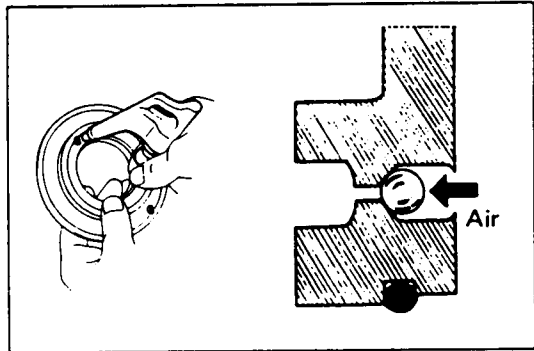
**ASSEMBLY OF REAR CLUTCH****INSTALL NEW O-RINGS ON PISTONS****INSTALL REAR CLUTCH INNER AND OUTER PISTON IN DRUM**

- (a) Press the inner piston into the drum with cup side up, being careful not to damage the O-rings.
- (b) Press the outer piston on the inner one with cup side up, being careful not to damage the O-rings.

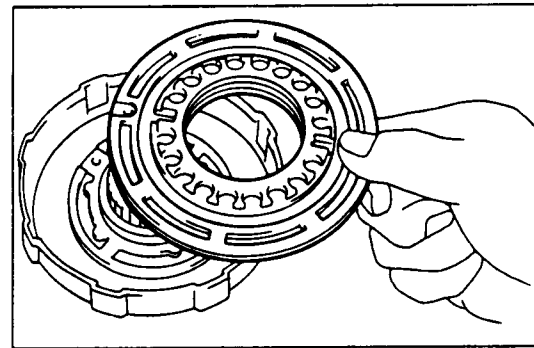

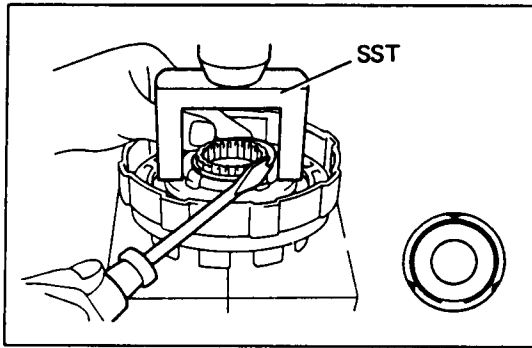
**INSTALL TWENTY PISTON RETURN SPRINGS AND SET SEAT WITH SNAP RING IN PLACE****COMPRESS RETURN SPRINGS AND INSTALL SNAP RING IN GROOVE**

- (a) Place SST on the spring seat, and compress the springs with a shop press.

SST 09350-20013

- (b) Using a screwdriver, install the snap ring.

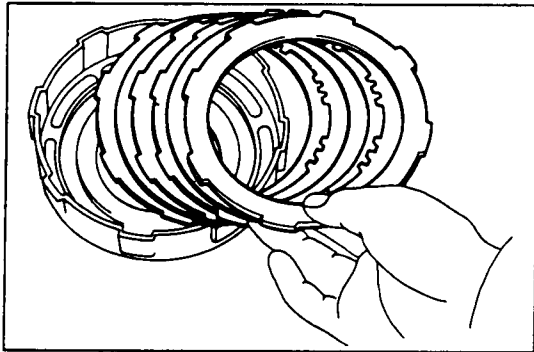
**INSTALL DISCS, PLATES AND FLANGE**

Using low-pressure compressed air (4 – 5 kg/cm², 57 – 71 psi or 392 – 490 kPa), blow all excess ATF from the discs.

Install in order: Plate-disc-plate-plate-disc-flange (rounded edge down)

INSTALL SNAP RING

Check that snap ring ends are not aligned with one of the cutouts.

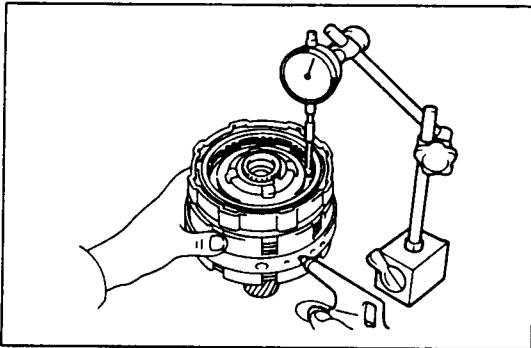
**CHECK PISTON STROKE OF REAR CLUTCH**

Install the rear clutch onto the center support. With a dial indicator, measure the stroke applying and releasing compressed air (4 – 8 kg/cm², 57 – 114 psi or 392 – 785 kPa) as shown.

**Standard piston stroke: 0.98 – 1.90 mm
(0.0386 – 0.0748 in.)**

If the stroke exceeds limit, the clutch pack is probably worn. If the stroke is less than the limit, parts may be misassembled or there may be excess ATF on the discs.

Center Support Assembly

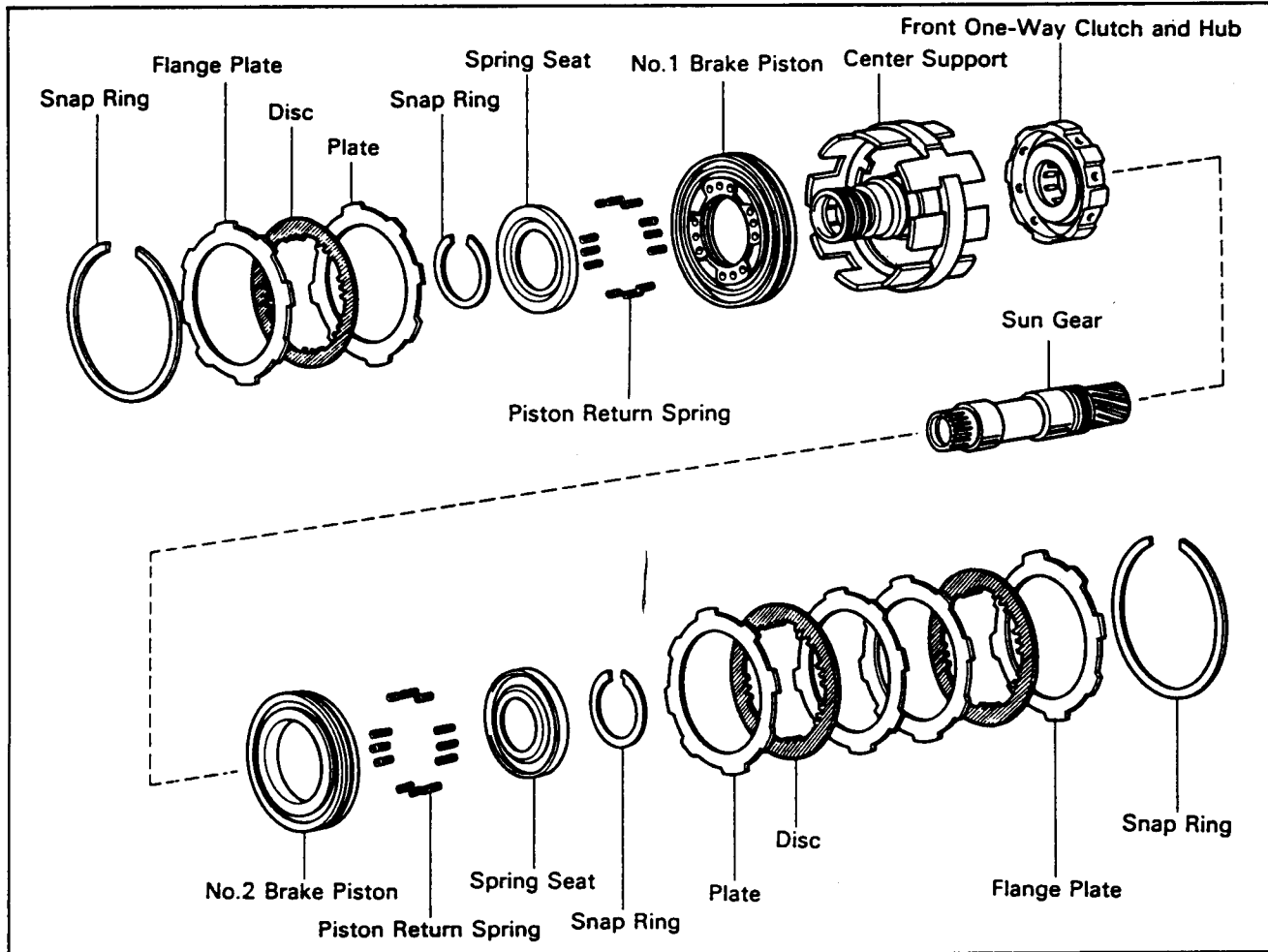

DISASSEMBLY OF CENTER SUPPORT ASSEMBLY

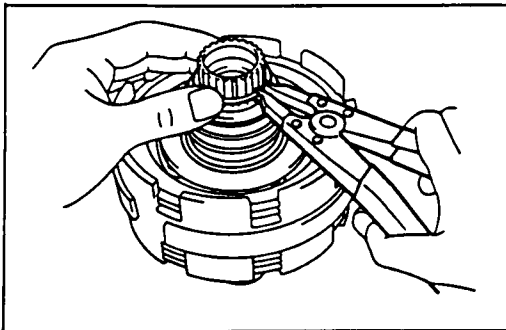

PULL CENTER SUPPORT ASSEMBLY FROM SUN GEAR

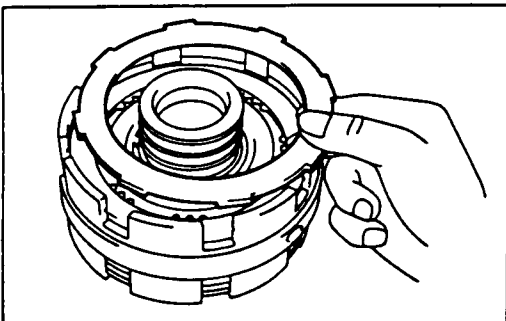

REMOVE SNAP RING FROM FRONT OF CENTER SUPPORT ASSEMBLY (NO. 1 BRAKE)

REMOVE CLUTCH FLANGE, DISC AND PLATE (NO. 1 BRAKE)



Technical Service Information

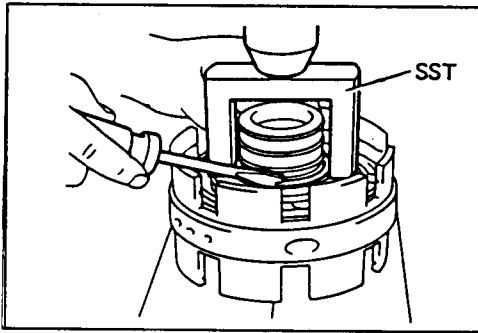

COMPRESS PISTON RETURN SPRINGS AND REMOVE SNAP RING

Place SST on spring retainer and compress the springs with a shop press.

Using a screwdriver, remove the snap ring.

SST 09350-20013

REMOVE SPRING RETAINER AND TWELVE SPRINGS

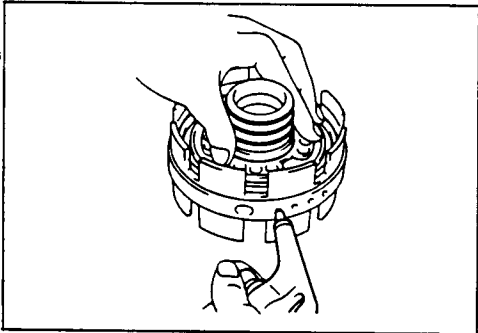

REMOVE NO. 1 BRAKE PISTON

Blow compressed air through the center support oil hole to remove the No. 1 brake piston.

If the piston does not pop out, lift it out with needle-nose pliers.

REMOVE NO. 1 BRAKE PISTON O-RINGS

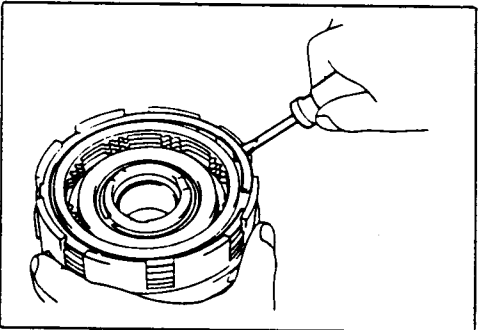

TURN CENTER SUPPORT ASSEMBLY OVER AND REMOVE REAR SNAP RING (NO. 2 BRAKE)

REMOVE CLUTCH FLANGE, DISCS AND PLATES (NO. 2 BRAKE)

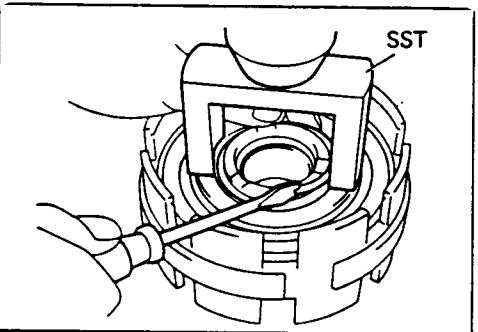

COMPRESS PISTON RETURN SPRINGS AND REMOVE SNAP RING

Place SST on spring retainer and compress the springs with a shop press.

Using a screwdriver, remove the snap ring.

SST 09350-20013

REMOVE SPRING RETAINER AND TWELVE SPRINGS

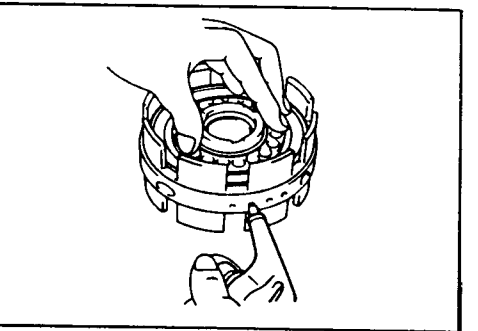

REMOVE NO. 2 BRAKE PISTON

Blow compressed air through the center support oil hole to remove the No. 2 brake piston.

If piston does not pop out, lift it out with needle-nose pliers.

REMOVE NO. 2 BRAKE PISTON O-RINGS

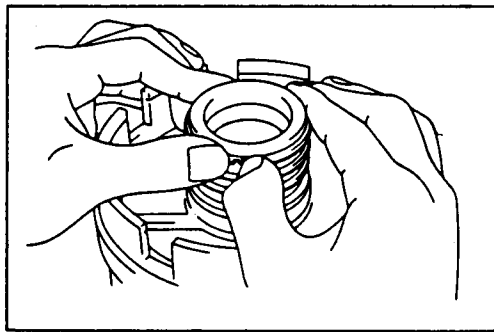

REMOVE THREE OIL SEAL RINGS FROM CENTER SUPPORT

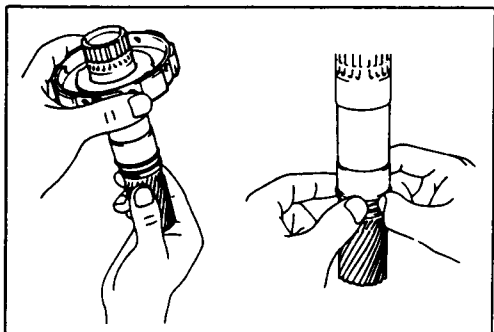

REMOVE ONE-WAY CLUTCH ASSEMBLY AND OIL SEAL RINGS FROM SUN GEAR

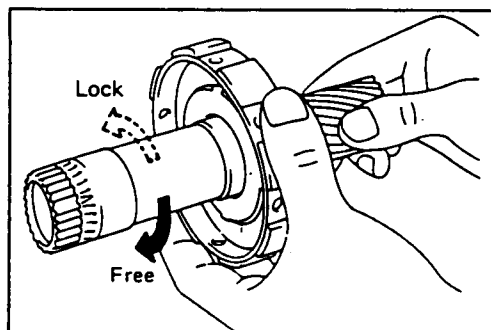

INSPECTION OF CENTER SUPPORT ASSEMBLY

CHECK OPERATION OF ONE-WAY CLUTCH

Hold the No. 2 brake hub and turn the sun gear. The sun gear should turn freely counterclockwise and should lock clockwise.

If the one-way clutch does not work properly, replace it.

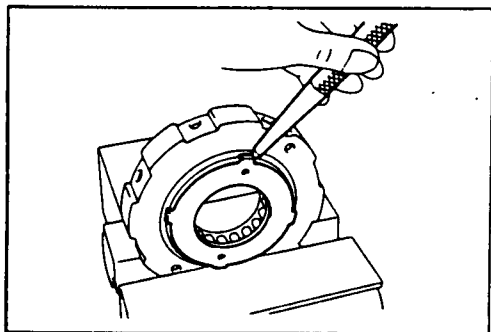

IF NECESSARY, REPLACE ONE-WAY CLUTCH

- (a) Bend several tabs back with a tapered punch.
- (b) Pry off the retainer with a screwdriver. Leave the other retainer on the hub.
- (c) Remove the one-way clutch.

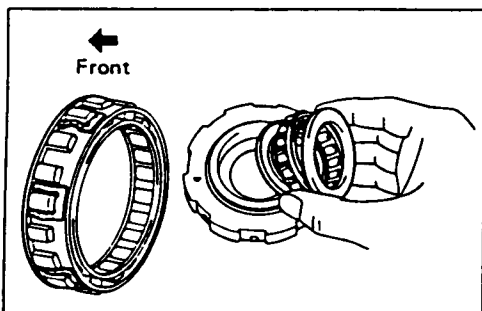

- (d) Install the one-way clutch into the brake hub, facing the spring cage toward the front.

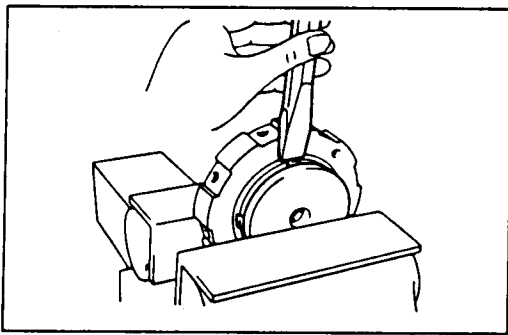

- (e) Hold the brake hub in a vise with soft jaws, and flatten the ears with a chisel.
- (f) Check to make sure the retainer is centered.

NOTE: Do not allow the discs to dry out. Prepare new discs by soaking them at least two hours in ATF.

ASSEMBLY OF CENTER SUPPORT ASSEMBLY

(See page AT-57)

INSTALL TWO OIL SEAL RINGS AND ONE-WAY CLUTCH ASSEMBLY ON SUN GEAR

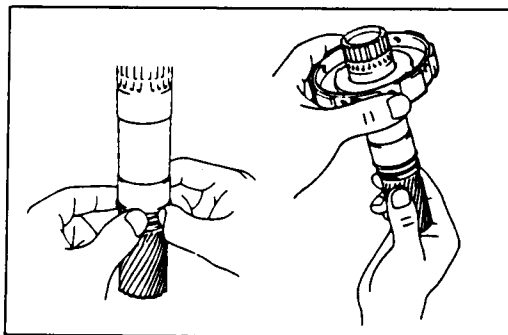

INSTALL THREE OIL SEAL RINGS ON CENTER SUPPORT

Spread rings apart and slip them into the groove. Hook both ends by hand.

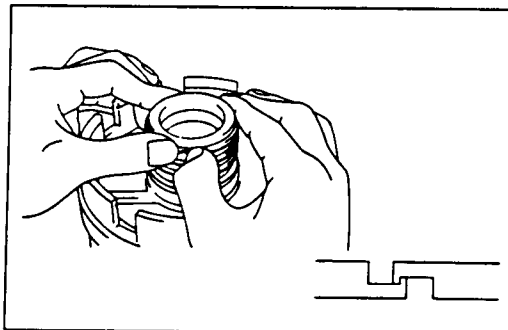

INSTALL NEW O-RINGS ON PISTON

INSTALL NO. 1 BRAKE PISTON IN CENTER SUPPORT

Press the No. 1 brake piston into the center support with the cup side up, being careful not to damage the O-rings.

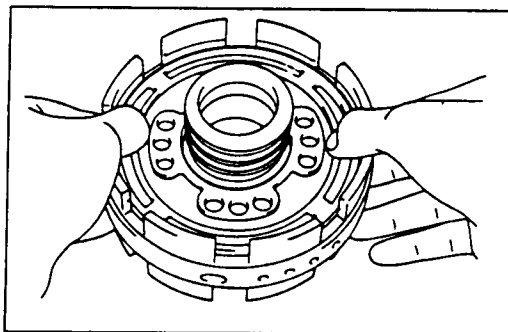

INSTALL TWELVE PISTON RETURN SPRINGS AND SET RETAINER WITH SNAP RING IN PLACE

COMPRESS RETURN SPRINGS AND INSTALL SNAP RING IN GROOVE

- (a) Place SST on the spring retainer, and compress the springs with a shop press.

SST 09350-20013

- (b) Using a screwdriver, install the snap ring.

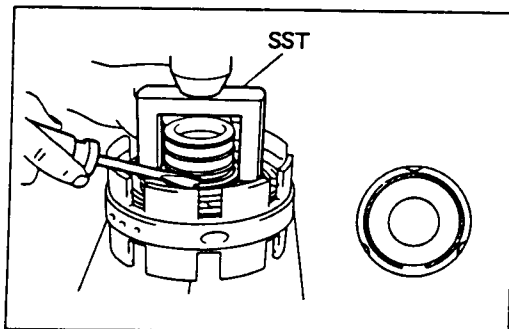

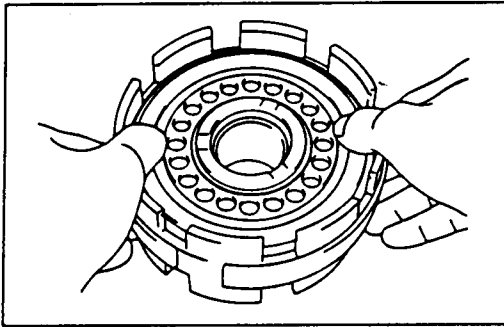

INSTALL NEW O-RINGS ON PISTON AND CENTER SUPPORT

TURN CENTER SUPPORT OVER AND INSTALL NO. 2 BRAKE PISTON

Press the No. 2 brake piston into the center support with the cup side up, being careful not to damage the O-rings.

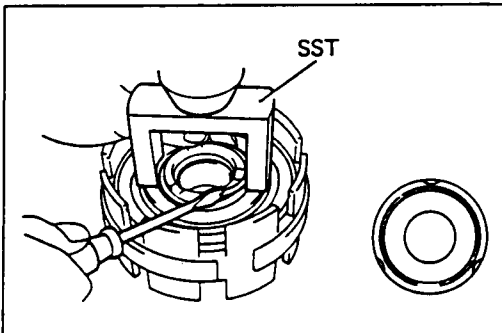

INSTALL TWELVE PISTON RETURN SPRINGS AND SET RETAINER WITH SNAP RING IN PLACE

COMPRESS RETURN SPRINGS AND INSTALL SNAP RING IN GROOVE

(a) Place SST on the spring retainer, and compress the springs with a shop press.

SST 09350-20013

(b) Using a screwdriver, install the snap ring.

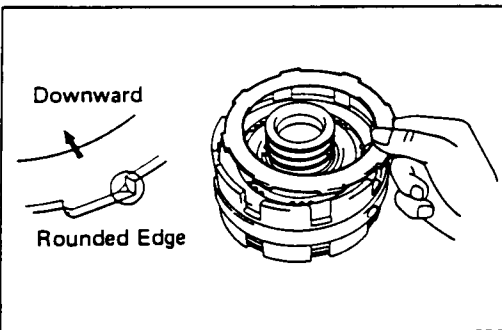

TURN CENTER SUPPORT OVER AND INSTALL NO. 1 BRAKE PISTON PLATE, DISC AND FLANGE

Using the low-pressure compressed air (4 – 5 kg/cm², 57 – 71 psi or 392 – 490 kPa), blow all excess ATF from the disc.

Install in order: Plate-disc-flange (rounded edge down)

INSTALL SNAP RING IN CENTER SUPPORT

Check that the snap ring ends are not aligned with one of the cutouts.

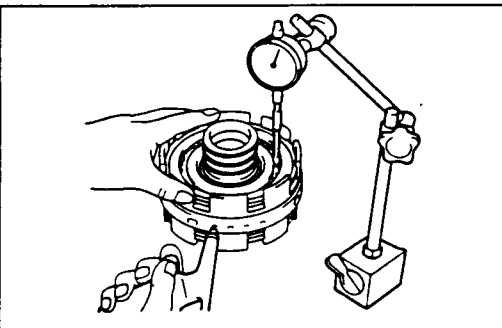

CHECK PISTON STROKE OF NO. 1 BRAKE

With a dial indicator, measure the stroke applying and releasing compressed air (4 – 8 kg/cm², 57 – 114 psi or 392 – 785 kPa) as shown.

Standard piston stroke: 0.65 – 1.30 mm
(0.0256 – 0.0512 in.)

Maximum piston stroke: 1.30 mm (0.0512 in.)

If the stroke exceeds the limit, the clutch pack is probably worn. If the stroke is less than the limit, parts may be misassembled or there may be excess ATF on the discs.

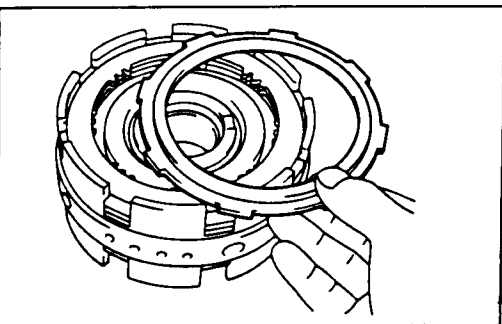

TURN CENTER SUPPORT OVER AND INSTALL NO. 2 BRAKE PLATES, DISCS AND FLANGE

Using the low-pressure compressed air (4 – 5 kg/cm², 57 – 71 psi or 392 – 490 kPa), blow all excess ATF from the discs.

Install in order: Plate-disc-plate-plate-disc-flange (rounded edge down)

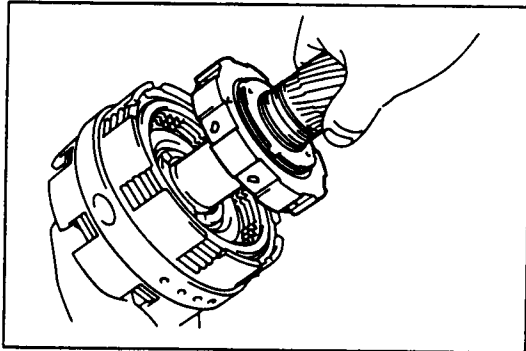
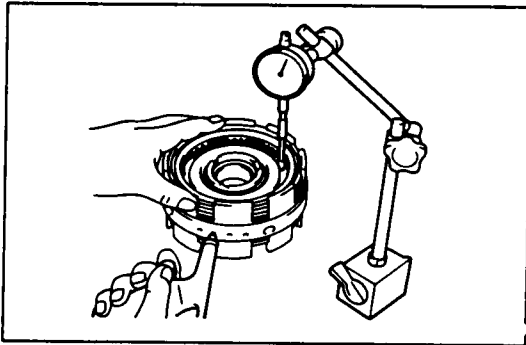
**INSTALL SNAP RING IN CENTER SUPPORT**

Check that the snap ring ends are not aligned with one of the cutouts.

CHECK PISTON STROKE OF NO. 2 BRAKE

With a dial indicator, measure the stroke applying and releasing compressed air (4 – 8 kg/cm², 57 – 114 psi or 392 – 785 kPa) as shown.

Standard piston stroke:

0.93 – 1.72 mm (0.0366 – 0.0677 in.)

Maximum piston stroke: 1.72 mm (0.0677 in.)

If the stroke exceeds the limit, the clutch pack is probably worn. If the stroke is less than the limit, parts may be misassembled or there may be excess ATF on the discs.

ASSEMBLE CENTER SUPPORT AND SUN GEAR SHAFT

- (a) Align the brake No. 2 disc flukes.
- (b) Mesh the brake hub with the discs, twisting and jiggling the hub as required.

Rear No.2 One-Way Clutch and Planetary Gear

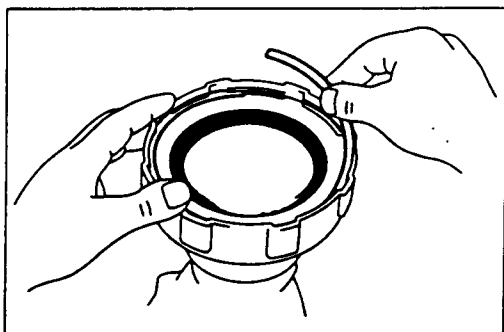
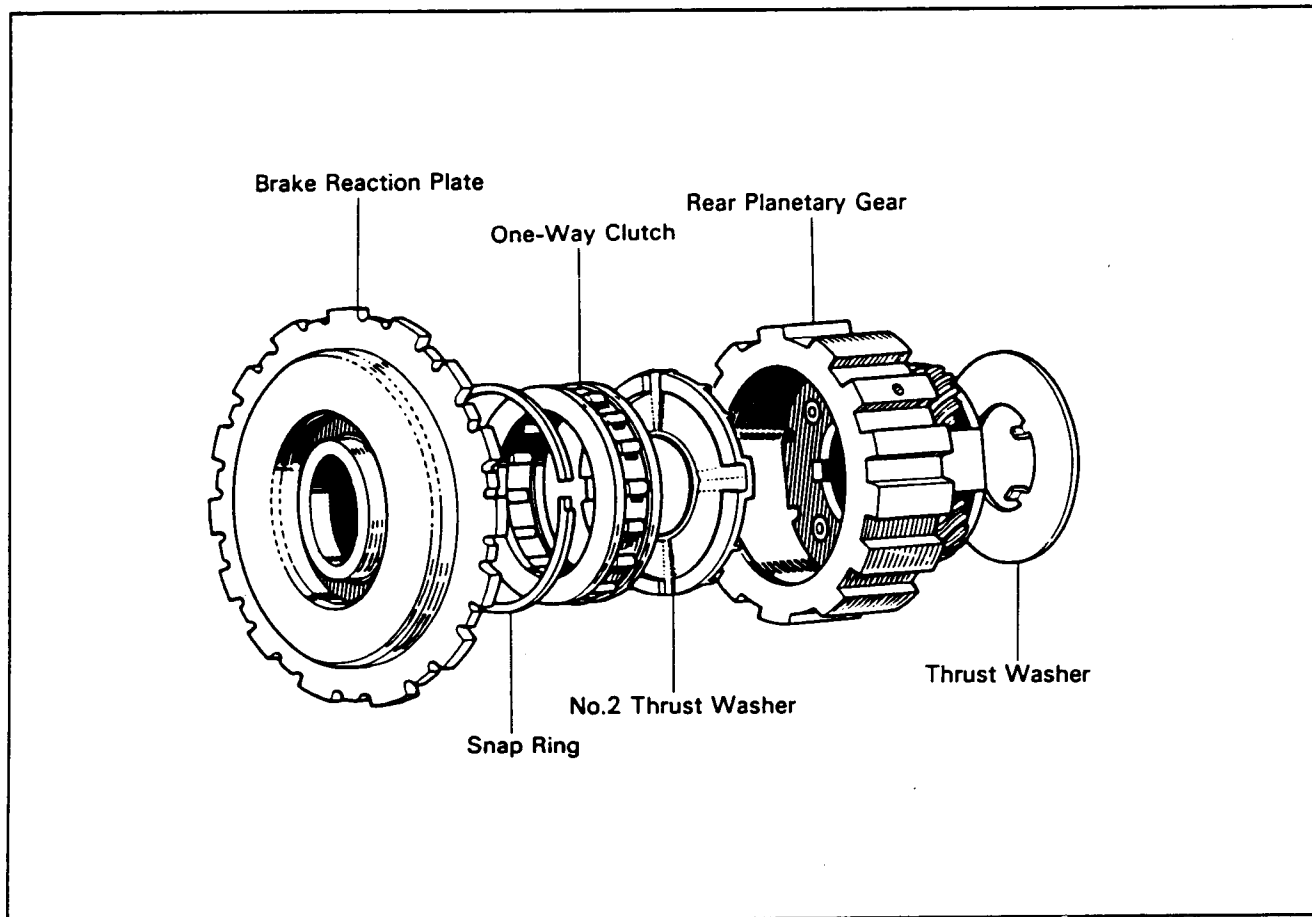

DISASSEMBLY OF REAR PLANETARY GEAR

REMOVE SNAP RING

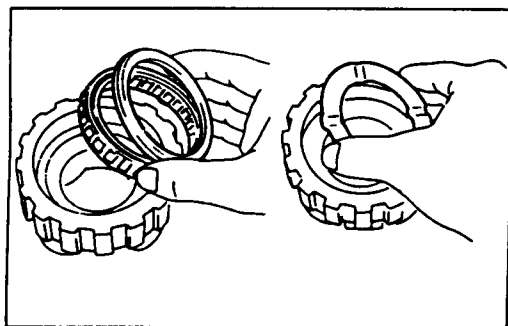

REMOVE ONE-WAY CLUTCH



Technical Service Information

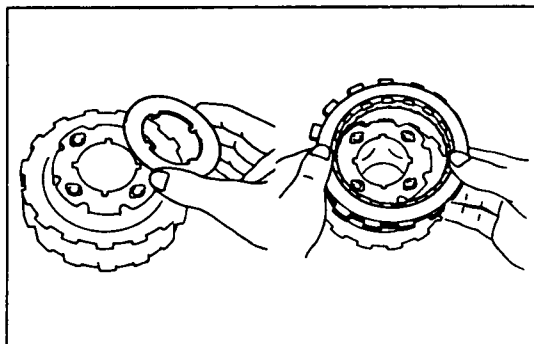

REMOVE NO. 2 THRUST WASHER FROM REAR PLANETARY GEAR

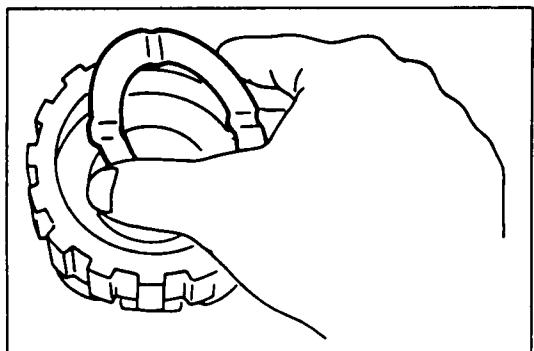

ASSEMBLY OF REAR PLANETARY GEAR

INSTALL NO. 2 THRUST WASHER IN FRONT OF PLANETARY PINION GEAR

Face the lugs downward and match them with slots in back of planetary gear.

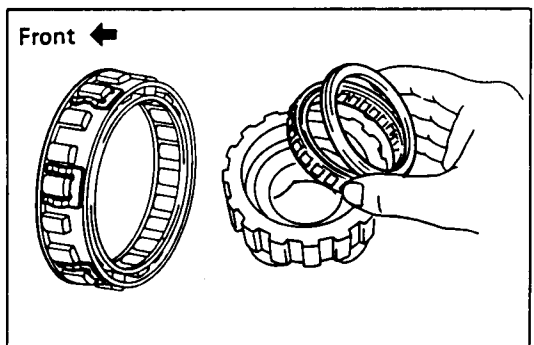

INSTALL ONE-WAY CLUTCH

Install the one-way clutch into the outer race facing the spring cage toward the front.

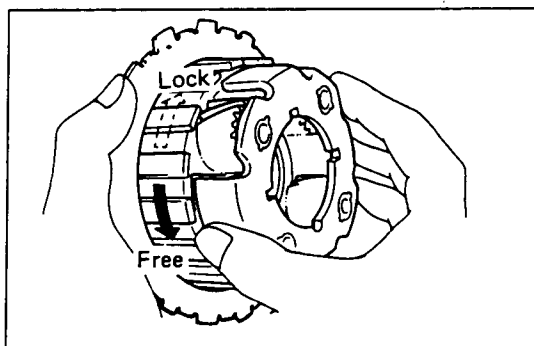

TEMPORARILY INSTALL REACTION PLATE ON PLANETARY

Insert into place for test of the one-way clutch.

TEST ONE-WAY CLUTCH

The planetary gear must rotate freely counterclockwise and lock clockwise.

If the clutch does not work correctly, it must be replaced.

Transmission Case and Rear Brake Piston

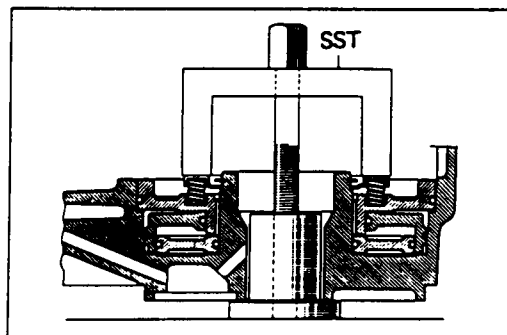
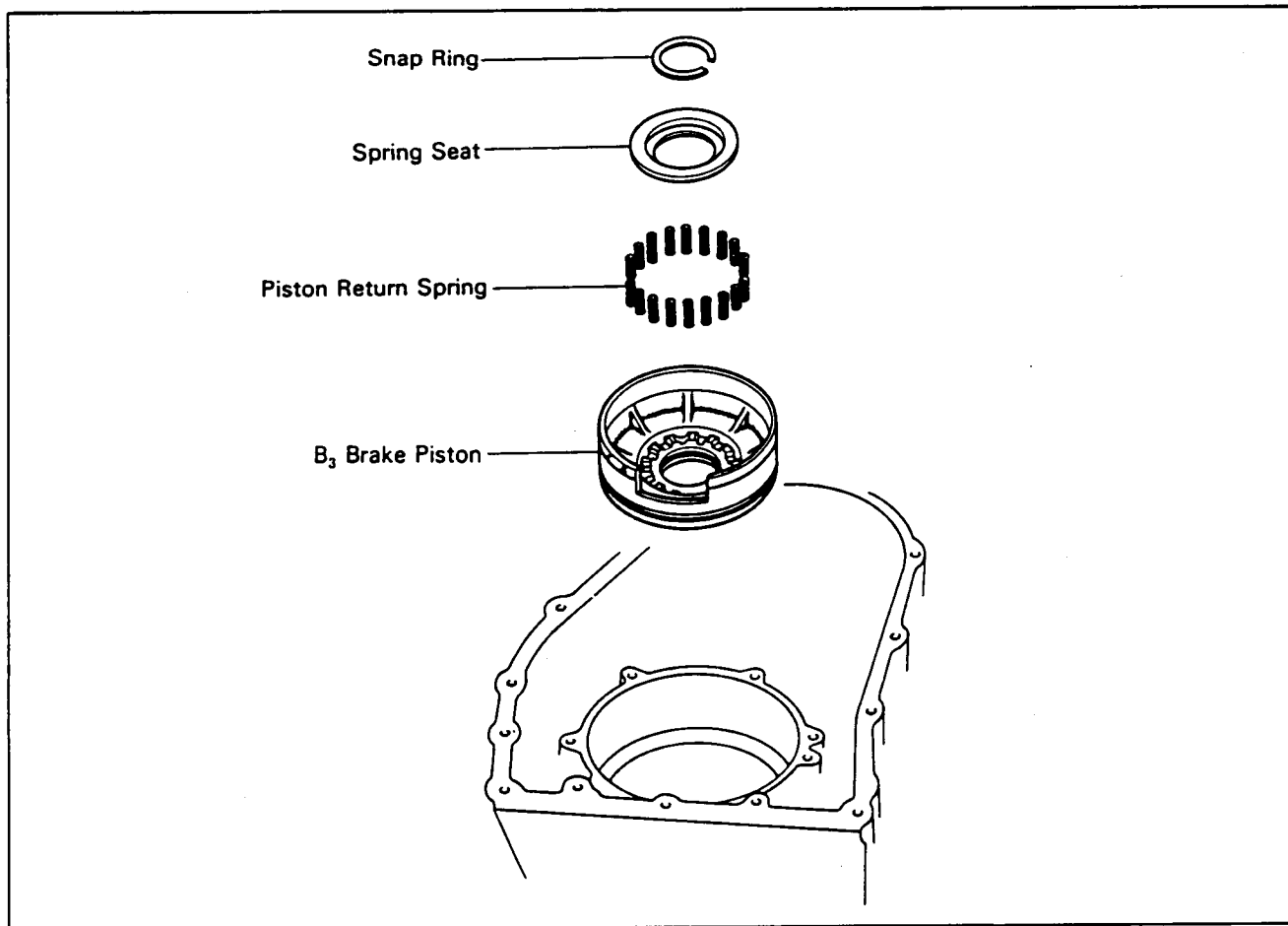

DISASSEMBLY OF TRANSMISSION CASE AND REAR BRAKE PISTONS

COMPRESS RETURN SPRINGS AND REMOVE SPRING RETAINER SNAP RING

- (a) Install the SST. Gradually and evenly tighten the bolt to compress the springs, being careful not to damage the transmission case with SST.

SST 09350-20013

- (b) Using the screwdriver and hook, remove the snap ring.

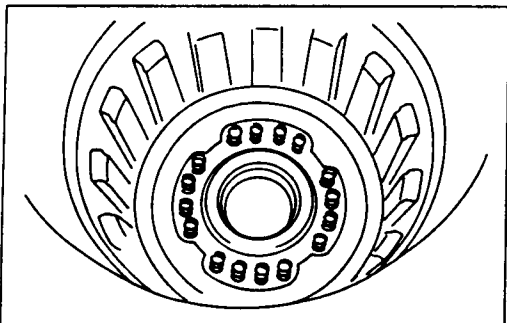

REMOVE SPRING RETAINER AND EIGHTEEN SPRINGS

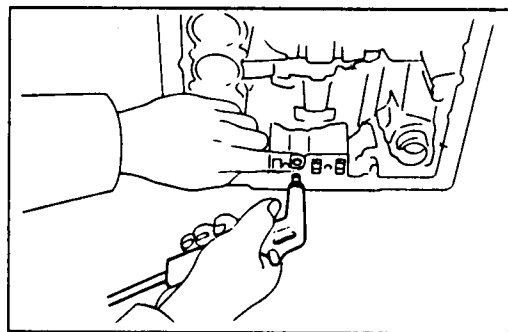

REMOVE OUTER PISTON AND REACTION SLEEVE WITH COMPRESSED AIR

Turn the case over face down on a workbench. Place several clean shop rags under the case to catch the piston. To pop them out, apply compressed air into the oil hole.

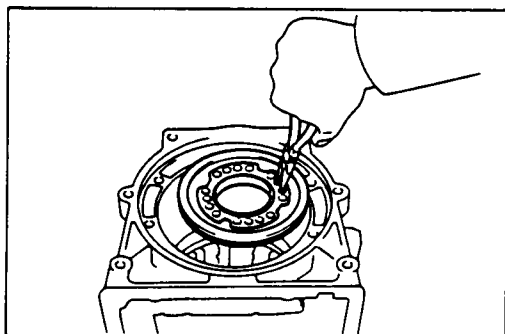

If the piston do not pop out with the compressed air, use needle-nose pliers to lift the piston from the case.

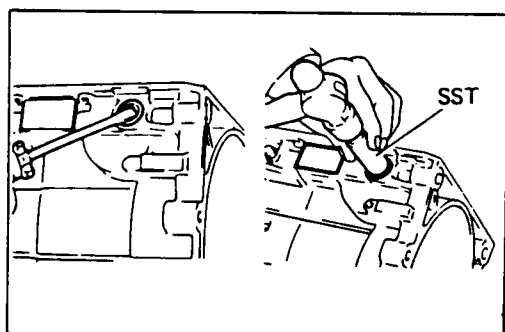

INSPECTION OF CASE COMPONENT GROUP

REPLACEMENT OF MANUAL SHAFT OIL SEALS

- Remove the manual shaft oil seals with a screwdriver.
- Drive in new left and right oil seals with SST.

SST 09350-20013

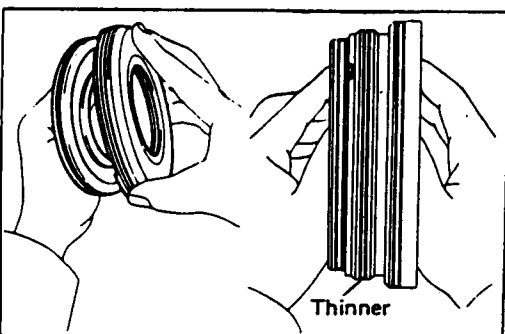

ASSEMBLY OF TRANSMISSION CASE AND REAR BRAKE PISTONS

INSTALL NEW O-RINGS ON PISTON

INSTALL PISTON IN CASE

Align the portion of the piston marked "A" with the groove on the transmission case.

NOTE: The groove marked "B" is larger than the other grooves.

CAUTION: Be careful not to damage the O-rings.

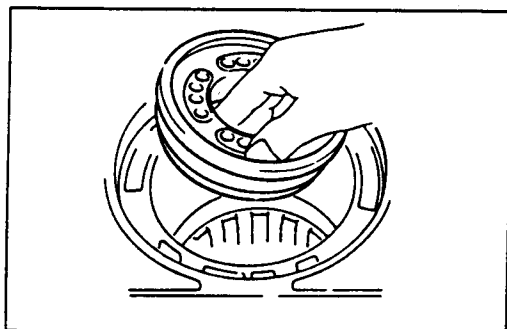



Technical Service Information

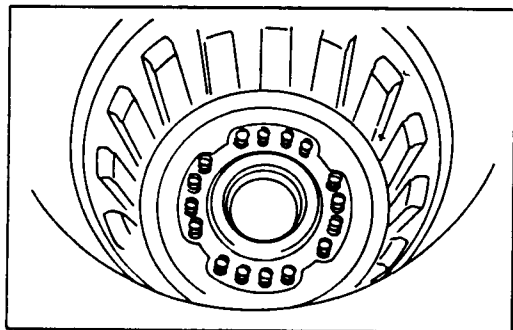

INSTALL SST BASE UNDER CASE

INSTALL EIGHTEEN PISTON RETURN SPRINGS AND SET RETAINER WITH SNAP RING IN PLACE

NOTE: The springs are visible through the cutout in the case, which helps position them more easily.

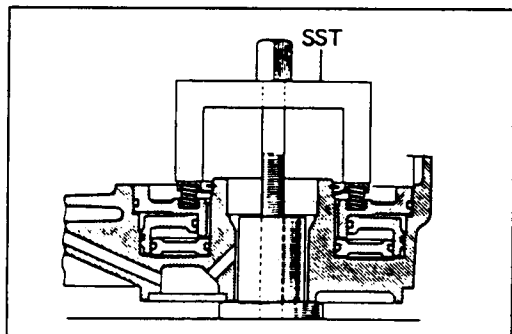

COMPRESS PISTON RETURN SPRINGS TO ALLOW INSTALLATION OF SNAP RING

CAUTION: Avoid bending the spring retainer by overtightening the bolts.

- (a) Carefully position the spring compressor on the spring retainer.
- (b) Gradually and evenly tighten the bolt to compress the springs, being careful not to damage the transmission case with SST.

SST 09350-20013

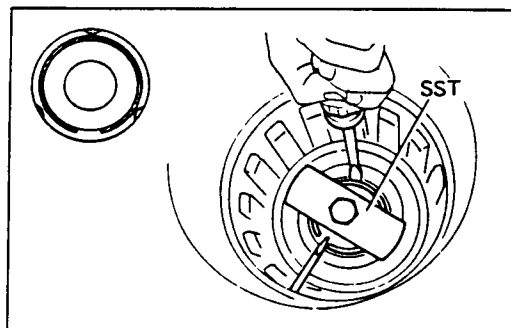

INSTALL SNAP RING

Push the snap ring into place with your fingers. Visually check to make sure it is fully seated and centered by three lugs on the spring retainer.

Remove the SST.

SST 09350-20013

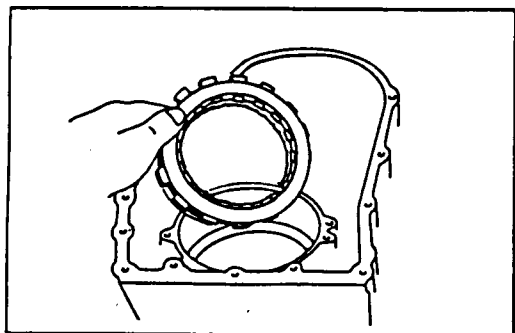

INSTALL BRAKE NO. 3 CUSHION PLATE CLUTCH PLATE AND DISC

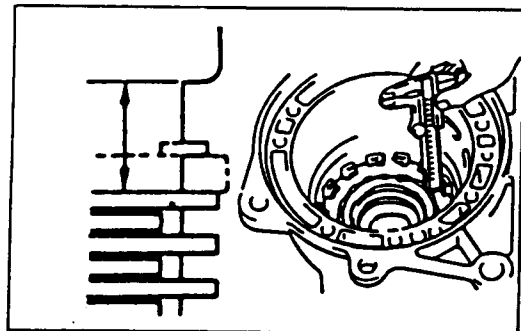

MEASURE NO. 3 BRAKE CLEARANCE

To prevent the plate from tilting while measuring, hold it down with two hammer handles.

Standard clearance: 10.04 – 11.30 mm
(0.3953 – 0.4449 in.)



VALVE BODY

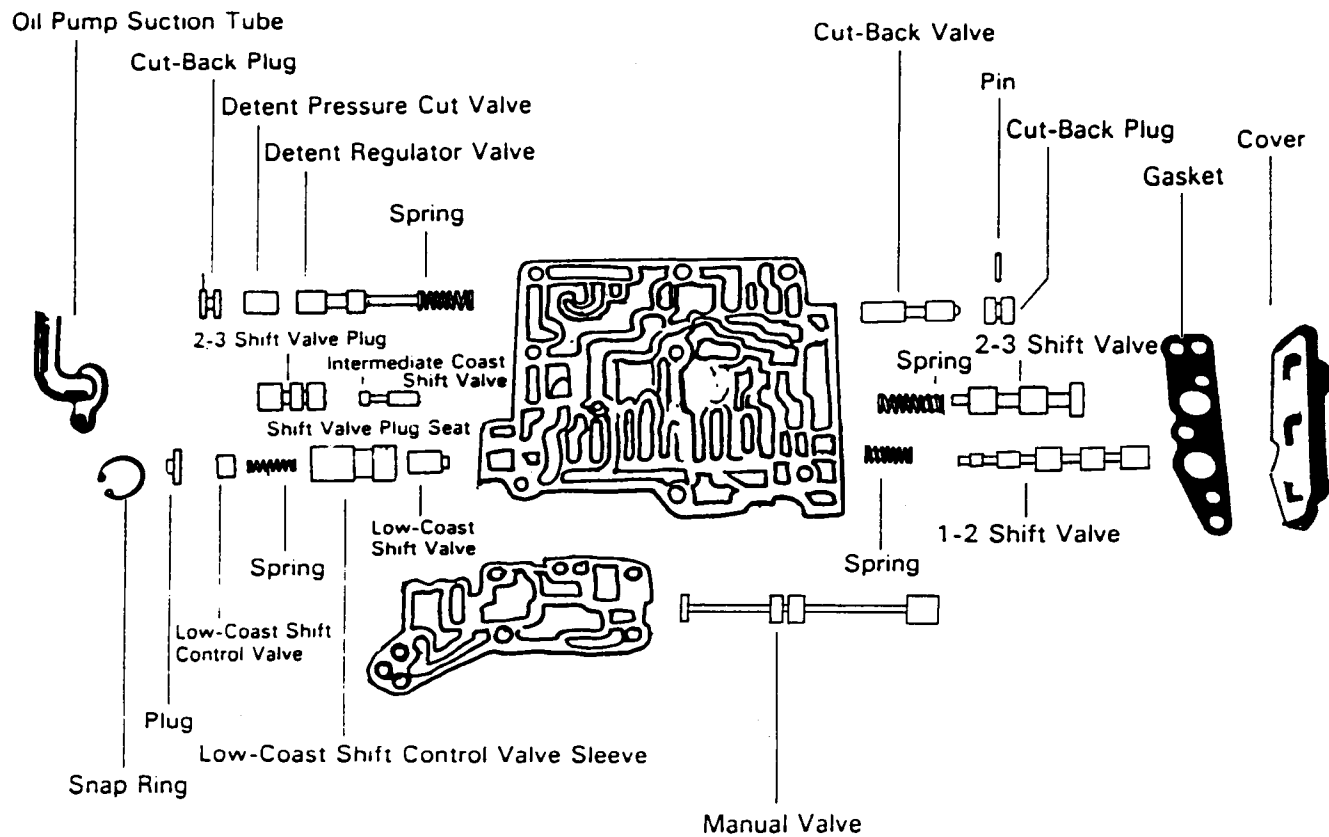



Technical Service Information

Throttle Valve

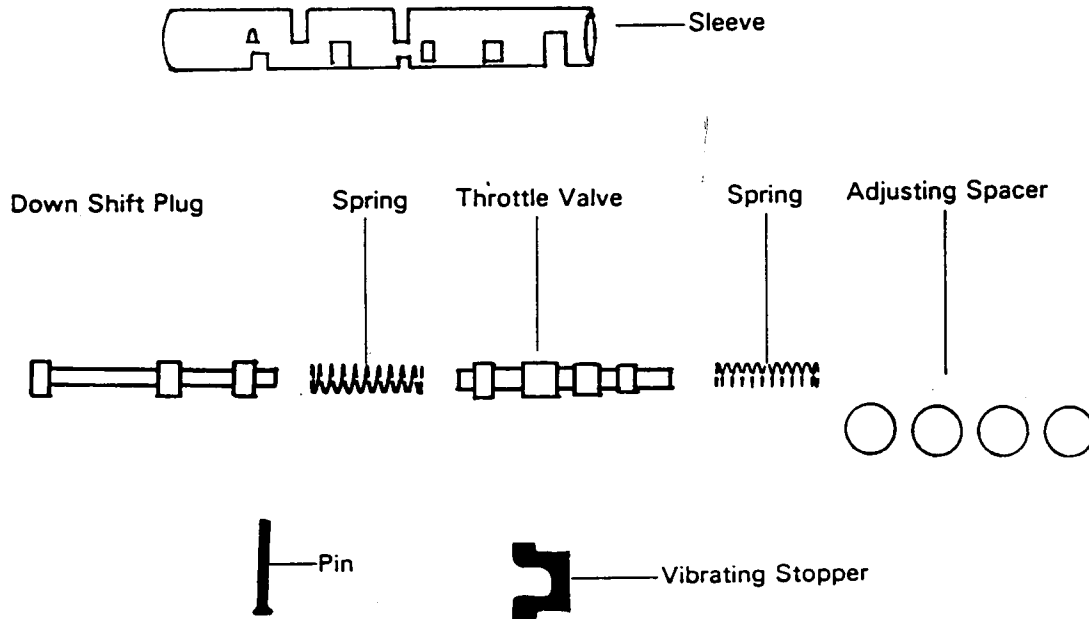

INSPECTION OF VALVE BODY AND THROTTLE VALVE

INSPECT VALVE SPRINGS

Check for damage, squareness, rust and distorted coils. Measure the spring free height and replace any spring if less than that shown below.

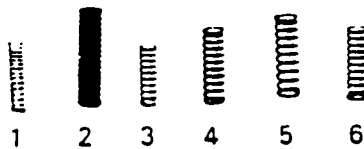

		Free length mm (in.)
1	1-2 shift valve spring	26.00 (1.0236)
2	Low-coast valve spring	36.50 (1.4370)
3	2-3 shift valve spring	22.10 (0.8701)
4	Detent regulator valve spring	27.40 (1.0787)
5	Throttle valve spring (Front)	30.03 (1.1823)
6	Throttle valve spring (Rear)	27.50 (1.0827)

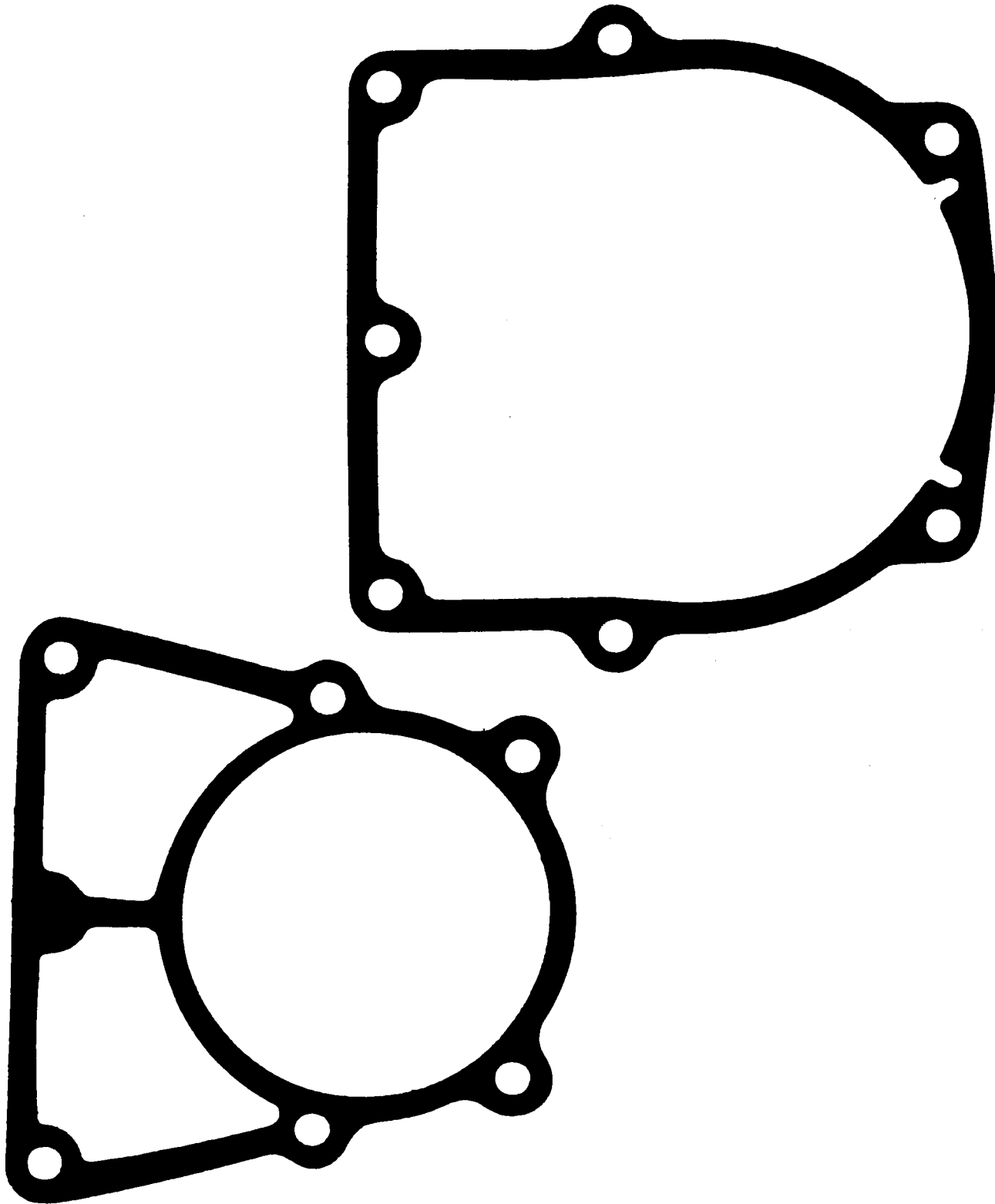

TERCEL A-55 1980-UP
EXTENSION HOUSING GASKETS



Technical Service Information

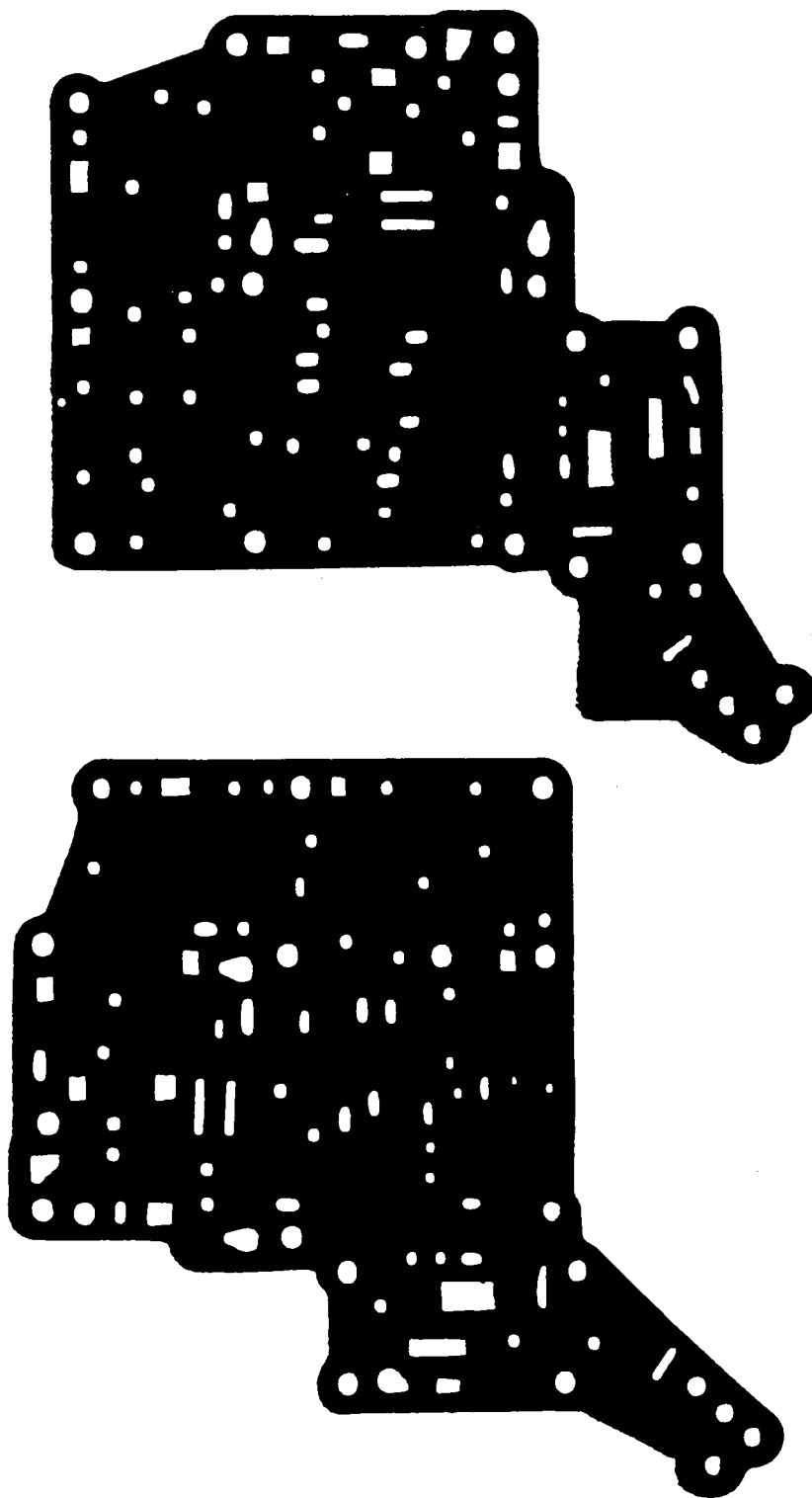

TERCEL A-55
1980-UP
V.B. GASKETS

TERCEL A-55 1980

ACCUMULATOR GASKETS

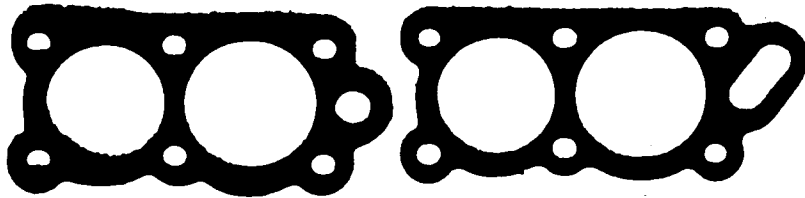

FILTER GASKETS

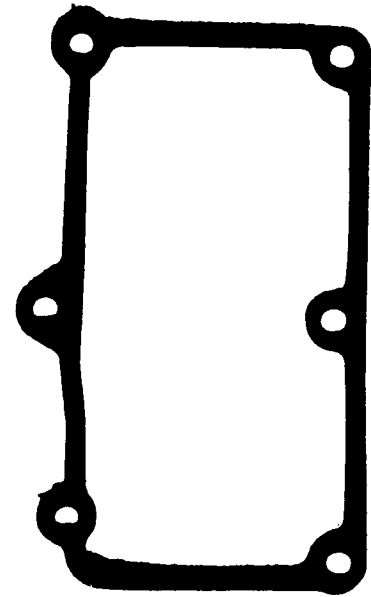

V.B. COVER GASKET



V.B. PLATE GASKET

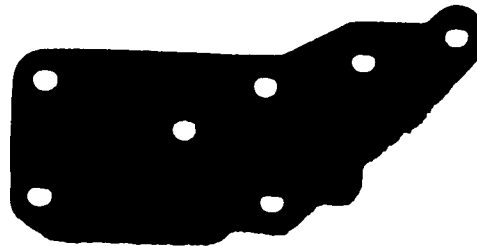

GOVERNOR GASKET

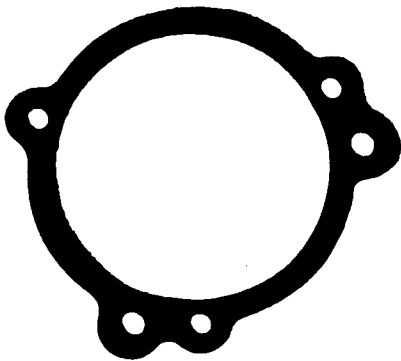

REAR V.B. GASKET

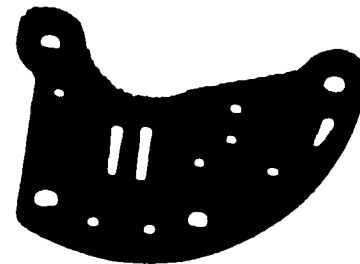

Governor Body

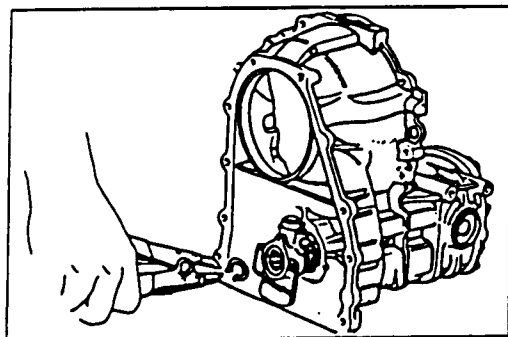
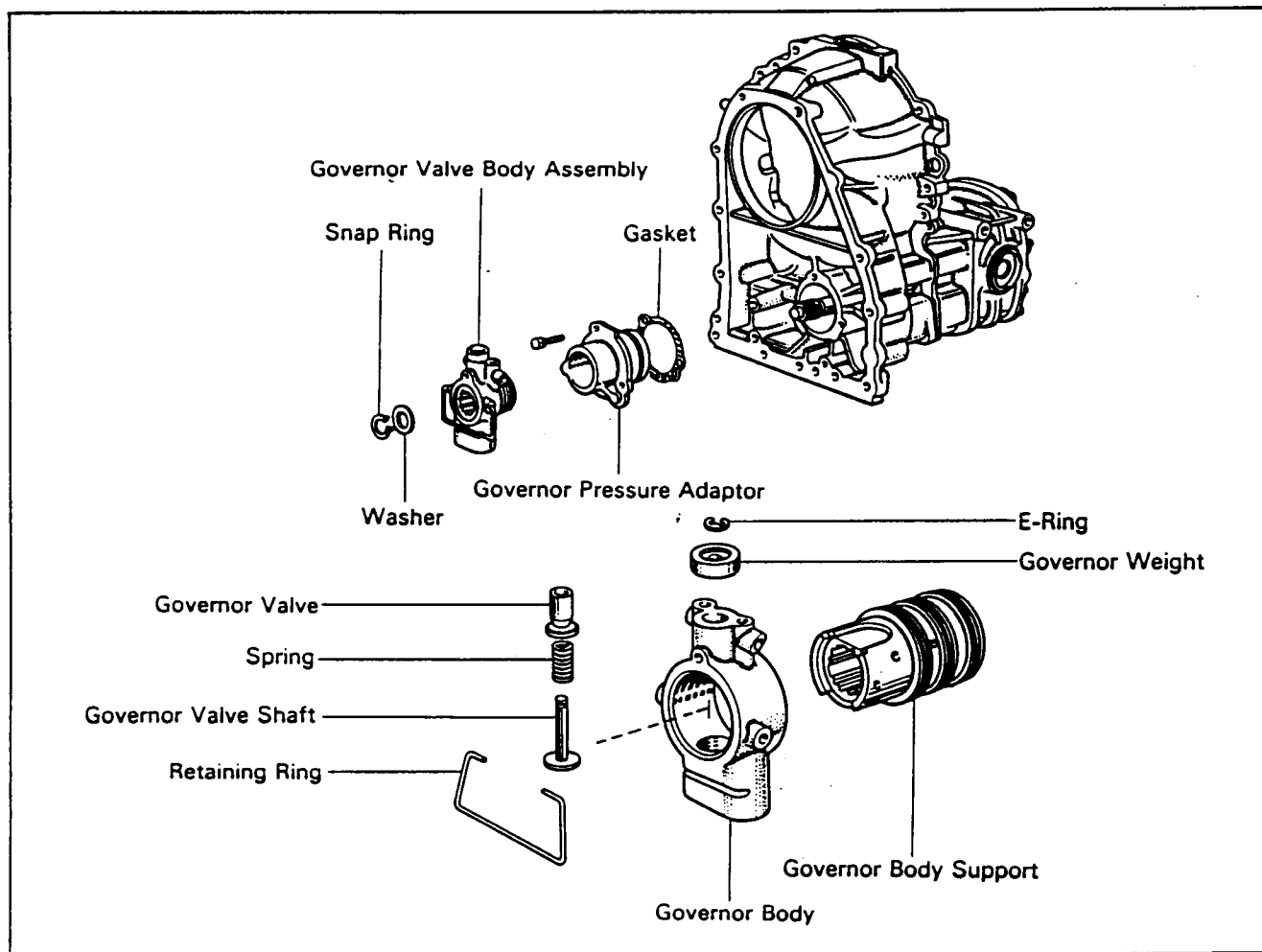

DISASSEMBLY OF GOVERNOR BODY

REMOVE SNAP RING

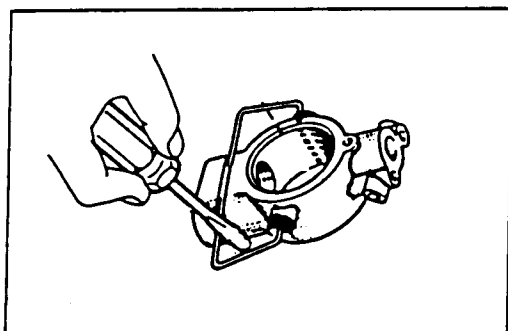

REMOVE GOVERNOR BODY SUPPORT

REMOVE RETAINING RING

Pry up the retaining ring slightly with a screwdriver and pull out the governor body from the support.

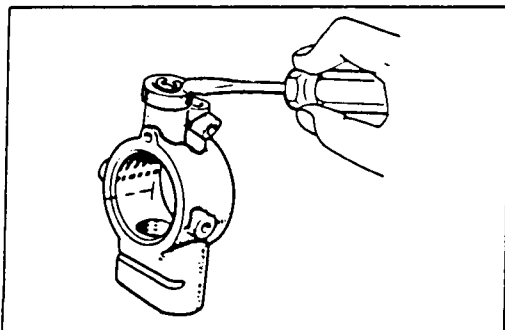

REMOVE E-RING AND GOVERNOR WEIGHT

Compress the spring by pushing up on the shaft and down on the weight. Remove the E-ring with a screwdriver. Lift off the governor weight.

REMOVE GOVERNOR VALVE

Slide it down through the bore.

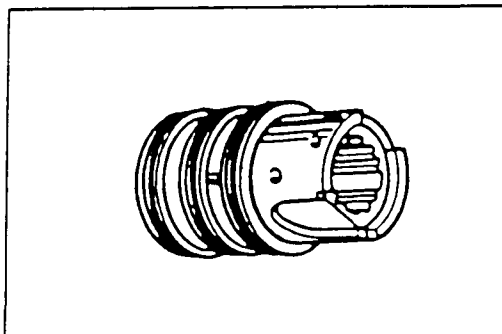

INSPECTION OF GOVERNOR BODY

INSPECT GOVERNOR SPRING

Measure the spring free height and replace if less than that shown below.

Free height: 19.60 mm (0.7717 in.)

INSPECT GOVERNOR BODY SUPPORT AND OIL SEAL RING

Check for wear or damage.

NOTE: Also check the differential drive pinion for wear.

INSPECT GOVERNOR PRESSURE ADAPTER AND OIL SEAL

Clean the oil strainer. Check for wear or damage.

Replace the oil seal.

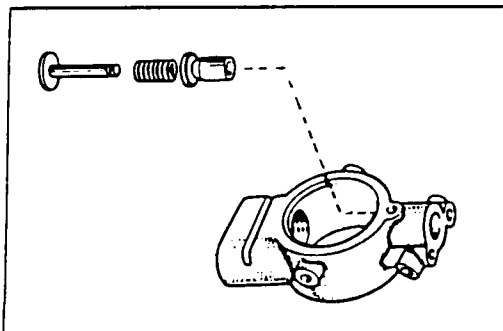
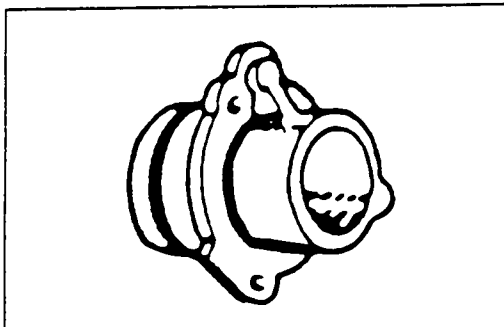

ASSEMBLY OF GOVERNOR BODY

INSTALL GOVERNOR VALVE, SPRING AND SHAFT

- (a) Slide down the governor valve through the bore.
- (b) Slide down the spring and shaft through the bore.

INSTALL GOVERNOR WEIGHT AND E-RING ON SHAFT

Compress the spring, and install the E-ring on the shaft with needle-nose pliers. Make sure that it is fully seated in the groove.

NOTE: Make sure that the valve moves smoothly.

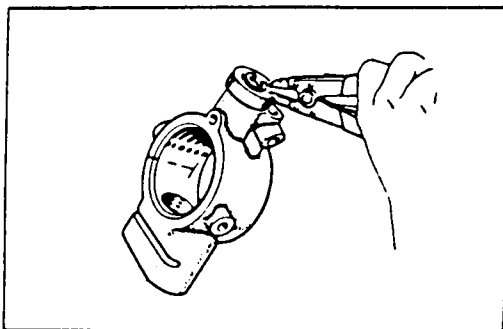

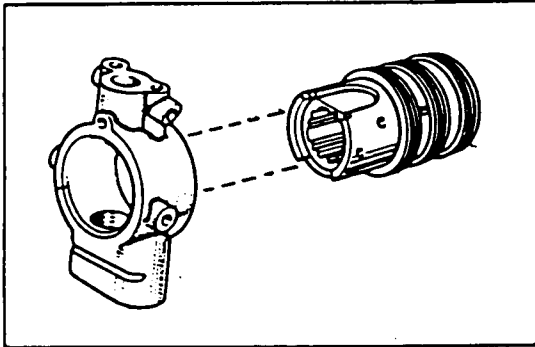

INSTALL GOVERNOR BODY TO SUPPORT

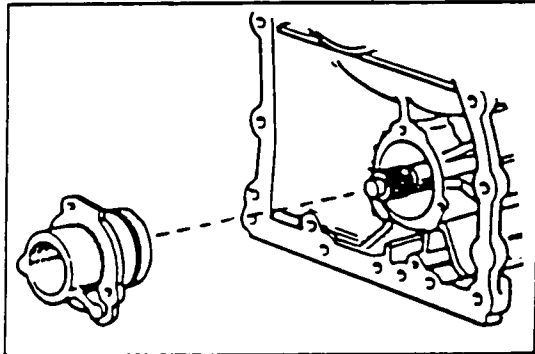

INSTALL GOVERNOR PRESSURE ADAPTER

(a) Coat the O-ring and drive pinion with MP grease.

NOTE: Wrap the differential drive pinion with vinyl tape to protect the oil seal from damage.

(b) Insert the oil strainer in the adapter.

(c) Tighten the set bolts.

Torque: 55 kg-cm (48 in.-lb, 5.4 N·m)

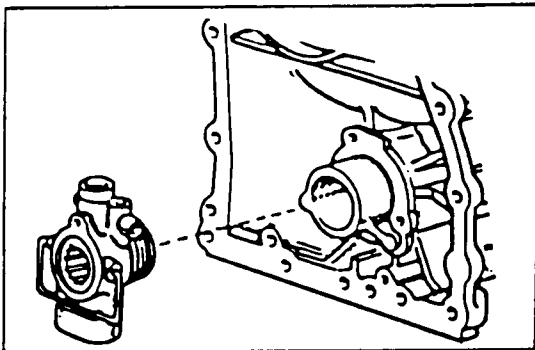

INSTALL GOVERNOR VALVE ASSEMBLY

NOTE: Confirm proper assembly.

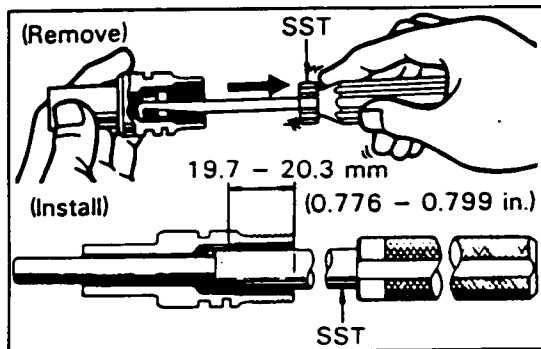

Speedometer Gear

INSPECTION OF SPEEDOMETER GEAR

IF NECESSARY, REPLACE SPEEDOMETER GEAR OIL SEAL

(a) Using SST, remove the oil seal.

SST 09921-00010

(b) Using SST, install the new oil seal.

SST 09201-60011

Torque Converter

CLEAN TORQUE CONVERTER

If the transmission is contaminated, the torque converter and transmission cooler should be thoroughly flushed, using Toyota Transmission Cleaner.

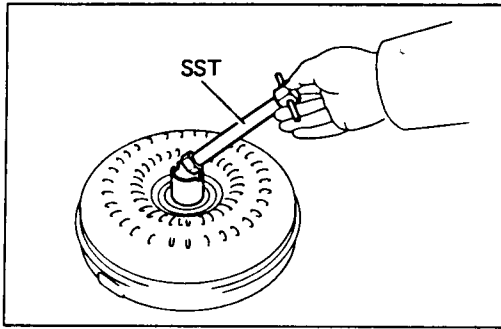

INSPECTION OF TORQUE CONVERTER

INSERT SST IN END OF TORQUE CONVERTER

Insert a turning tool in the inner race of the one-way clutch.

SST 09350-20013

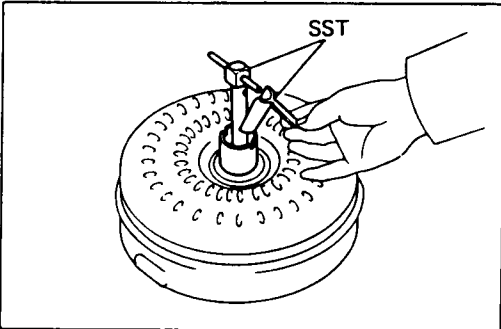

TEST ONE-WAY CLUTCH

- (a) Rapidly turn the SST to the right and left.
- (b) At this time, you should feel resistance to the left but not to the right.

NOTE:

- (1) When turning the SST to the left, the one-way clutch is functioning and the stator is turning, creating resistance against the ATF.
- (2) When turning the SST to the right, the one-way clutch is sliding freely and the stator is not turning so there is no resistance from the ATF.
- (3) The one-way clutch lock test cannot be performed when the converter is not installed. Therefore, it should be checked by performing a stall test after the converter has been properly installed.

SST 09350-20013

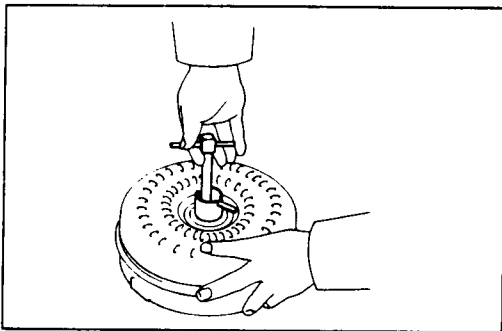

Electric Parts

INSPECT NEUTRAL START SWITCH

- (a) Make sure that there is continuity between terminals 2 and 3 in "P" and "N" ranges.
- (b) Make sure that there is continuity between terminals 1 and 1 in "R" range.

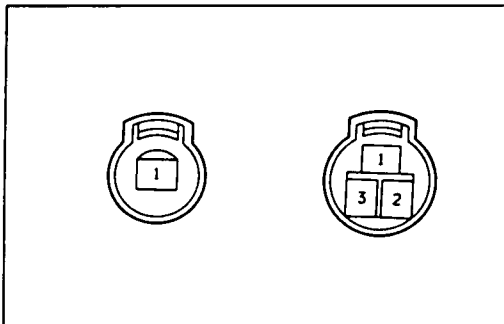

FOUR-WHEEL DRIVE CHANGE-OVER MECHANISM COMPONENT

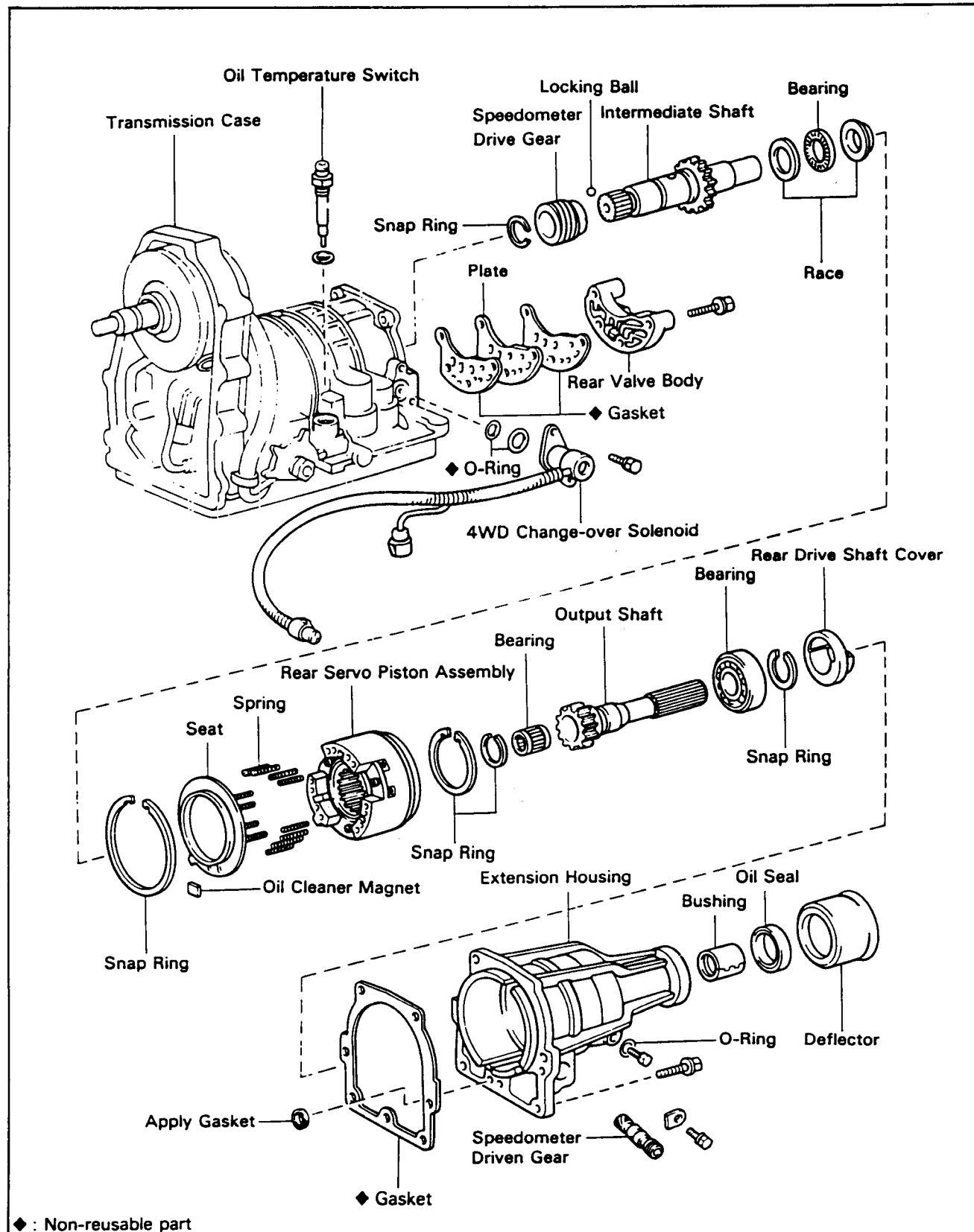

Disassembly of 4WD Change-over Mechanism

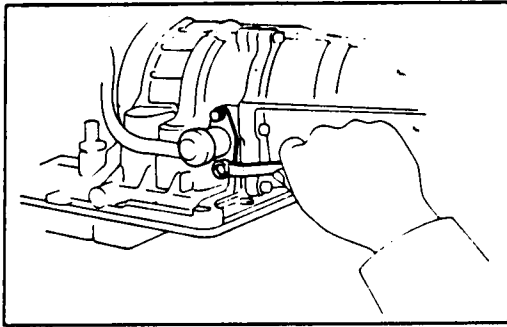

REMOVE 4WD CHANGE-OVER SOLENOID

- (a) Remove the two bolts and solenoid.
- (b) Remove the two O-rings.

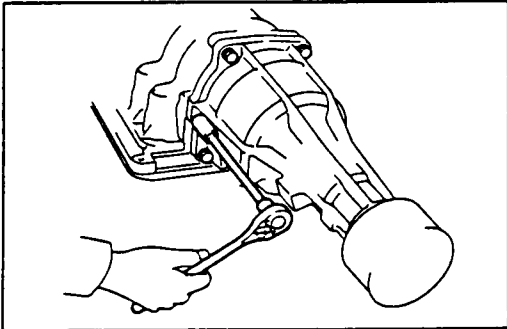

REMOVE SPEEDOMETER DRIVEN GEAR

REMOVE EXTENSION HOUSING AND GASKET

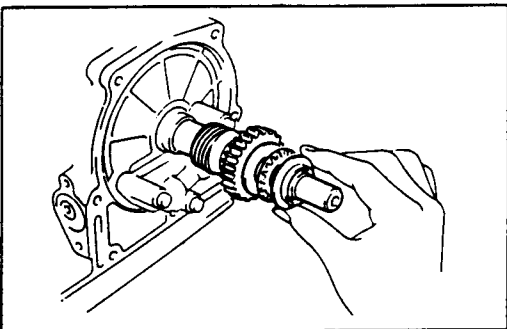

REMOVE INTERMEDIATE SHAFT

- (a) Remove the thrust bearing and two races.
- (b) Remove the intermediate shaft.

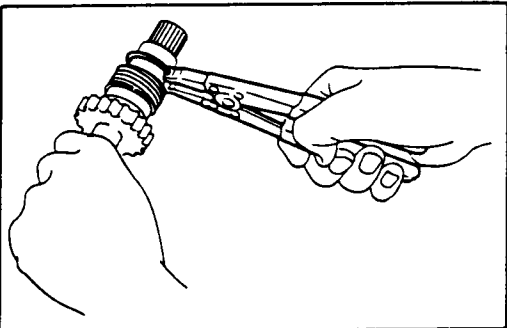

REMOVE SPEEDOMETER DRIVE GEAR

- (a) Using snap ring pliers, remove the snap ring from the intermediate shaft.
- (b) Remove the speedometer drive gear and locking ball.

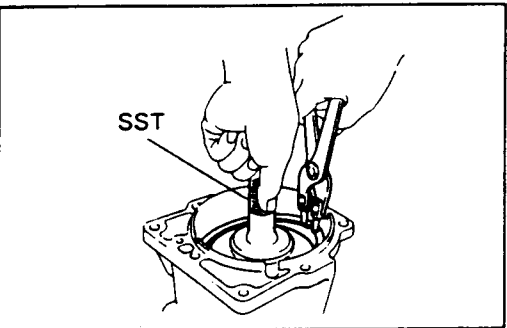

REMOVE REAR SERVO PISTON ASSEMBLY

- (a) Using SST, push down the piston spring seat and remove the snap ring.

SST 09223-41020

- (b) Remove the piston spring seat and twelve springs from the rear servo piston.



Technical Service Information

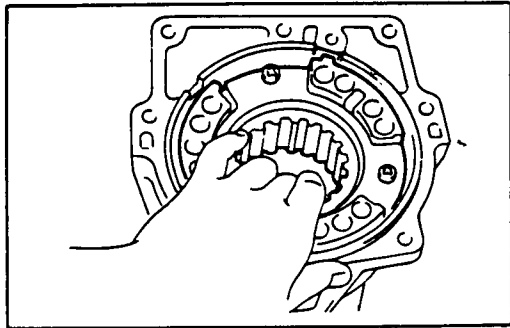

(c) Remove the rear servo piston assembly from the extension housing.

(d) Measure the compression spring free height.

Free height: 56 mm (2.21 in.)

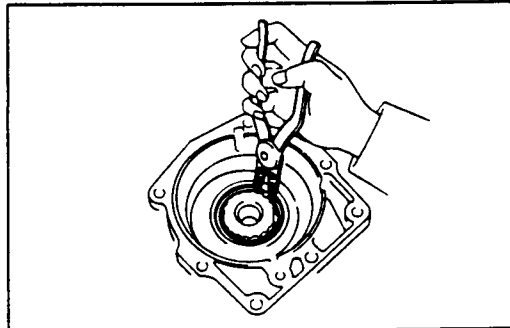

REMOVE REAR OUTPUT SHAFT

(a) Using snap ring pliers, remove the snap ring from the extension housing.

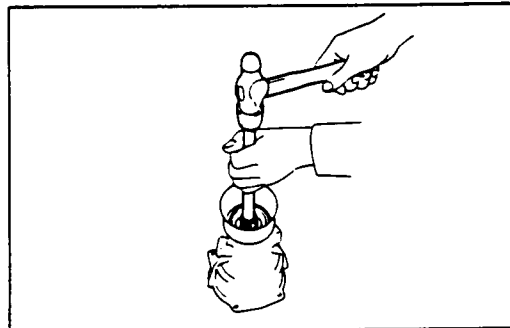

(b) Using a brass-bar and hammer, drive out the rear output shaft.

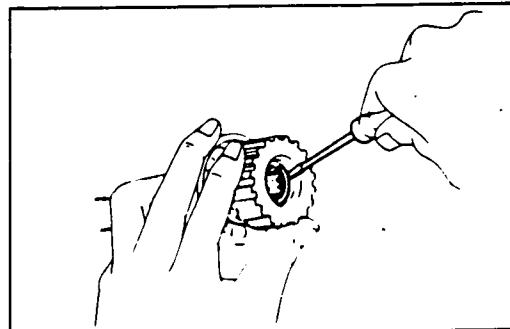

REMOVE NEEDLE ROLLER BEARING

(a) Using a screwdriver, remove the snap ring from the rear output shaft.

(b) Remove the needle roller bearing from the rear output shaft.

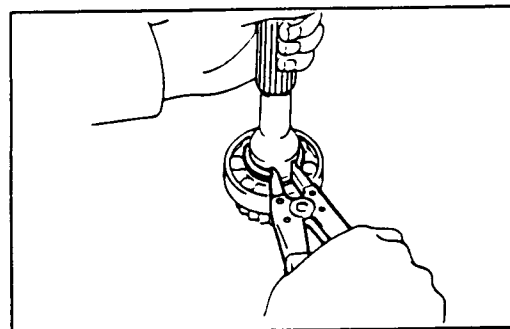

REMOVE RADIAL BALL BEARING

(a) Using snap ring pliers, remove the snap ring from the rear output shaft.

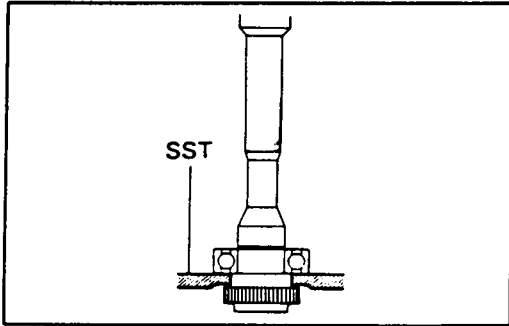

- (b) Using SST and a press, remove the radial ball bearing from the rear output shaft.

SST 09950-00020

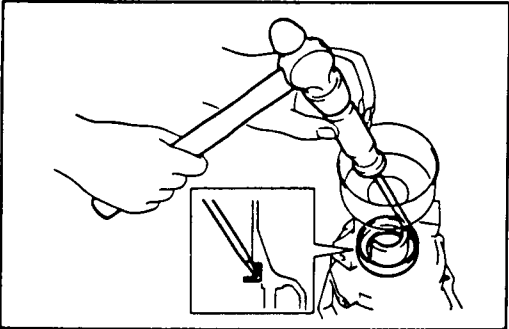

REMOVE REAR DRIVE SHAFT COVER

Using a screwdriver and, drive out the rear drive shaft cover from the extension housing.

CAUTION: Without deforming the cover, tap the L-shaped circumference level.

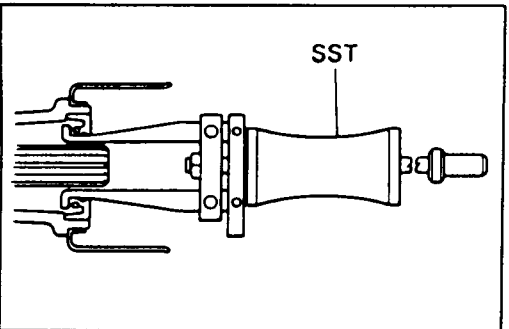

REMOVE EXTENSION HOUSING OIL SEAL

Using SST, remove the oil seal from the extension housing.

SST 09308-00010

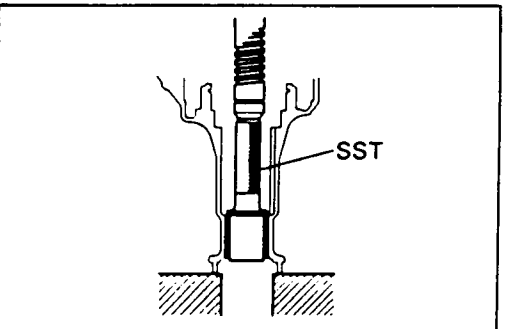

REMOVE EXTENSION HOUSING BUSHING

- Remove the deflector from the extension housing.
- Heat the extension housing to 80° – 100°C (176 – 212°F).
- Using SST and a press, remove the bushing.

SST 09307-12010

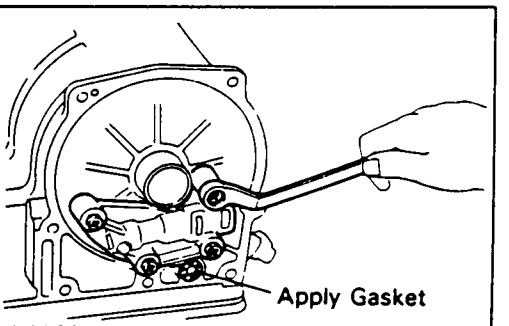

REMOVE REAR VALVE BODY

- Remove the four bolts.
- Remove the rear valve body with the plate and two gaskets.

REMOVE APPLY GASKET

Rear Servo Piston Assembly

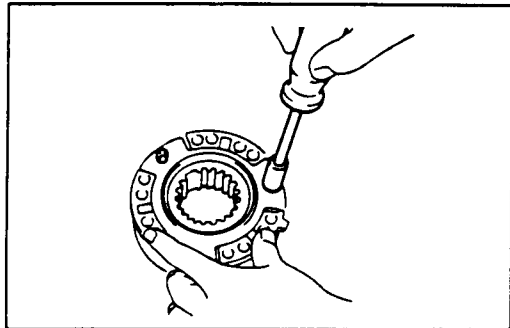
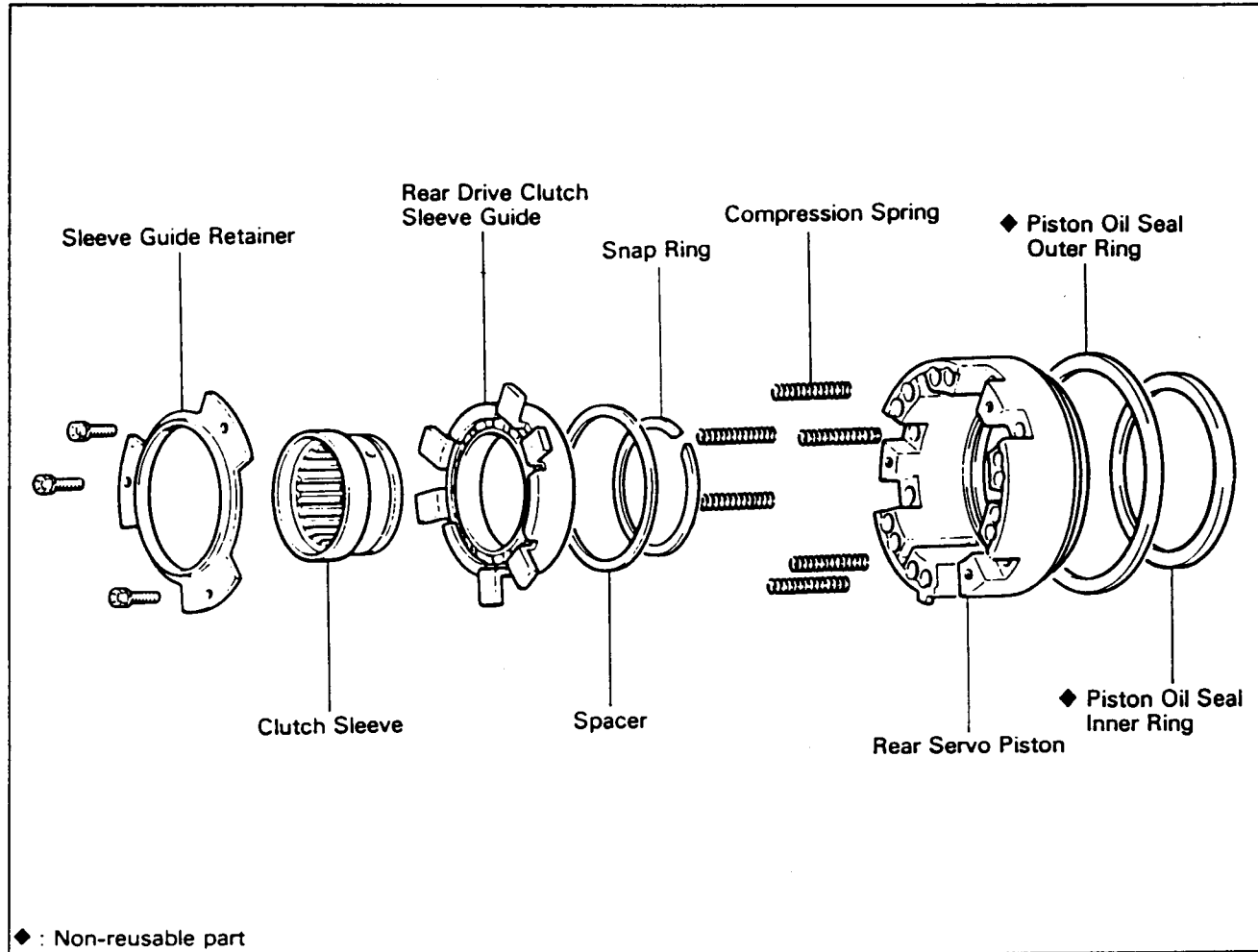

DISASSEMBLY OF REAR SERVO PISTON ASSEMBLY

REMOVE REAR SERVO PISTON

- (a) Remove the three bolts and sleeve guide retainer.
- (b) Remove the six compression springs.
- (c) Remove the rear drive clutch sleeve guide with clutch sleeve from the rear servo piston.
- (d) Remove the piston oil seal outer ring.
- (e) Remove the piston oil seal inner ring.

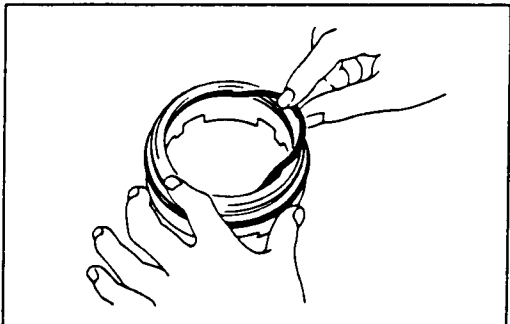

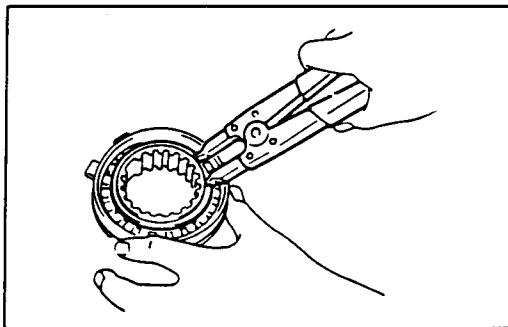

REMOVE CLUTCH SLEEVE

- (a) Using snap ring pliers, remove the snap ring.
- (b) Remove the spacer.
- (c) Remove the sleeve from the clutch sleeve guide.

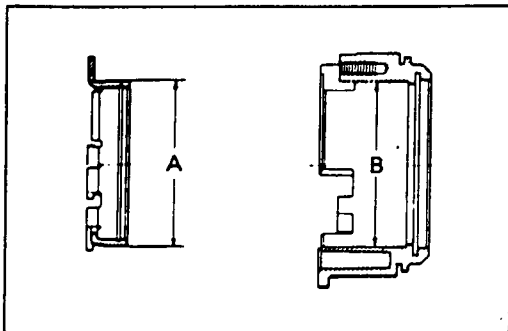

ASSEMBLY OF REAR SERVO PISTON ASSEMBLY

MEASURE DIAMETER OF REAR SERVO PISTON ASSEMBLY

- (a) Measure the outer diameter of the sliding portion of the clutch sleeve guide and inner diameter of the servo piston.

Standard A: 84.69 – 84.73 mm
(3.3342 – 3.3358 in.)

B: 85.00 – 85.04 mm
(3.3465 – 3.3480 in.)

- (b) Measure the outer diameter of the servo piston, inner diameter of the sliding part, inner diameter of the extension housing and outer diameter of the sliding part.

Standard C: 113.79 – 113.82 mm
(4.4799 – 4.4811 in.)

D: 114.00 – 114.04 mm
(4.4882 – 4.4898 in.)

E: 82.30 – 82.34 mm
(3.2402 – 3.2417 in.)

F: 81.89 – 81.92 mm
(3.2240 – 3.2252 in.)

- (c) Check each sliding part for scoring or wear.

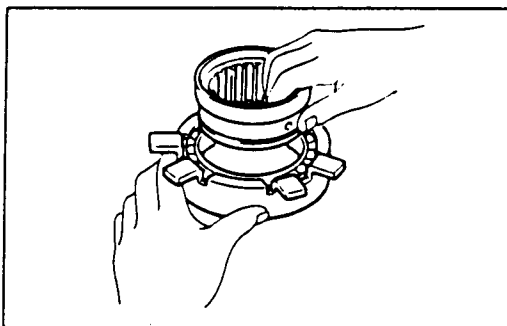
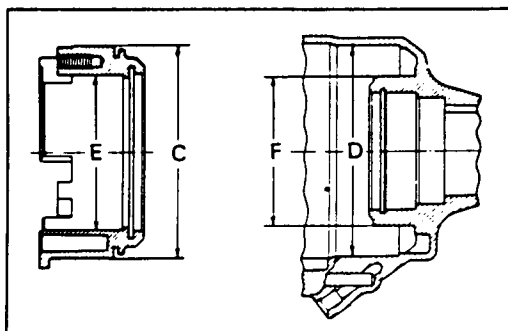

INSTALL CLUTCH SLEEVE TO CLUTCH SLEEVE GUIDE

- (a) Install the sleeve to the clutch sleeve guide.
- (b) Install the spacer.

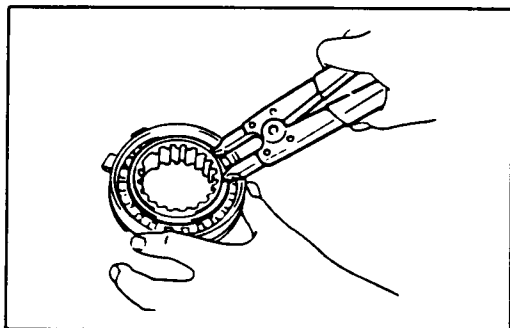

- (c) Using snap ring pliers, install the snap ring.

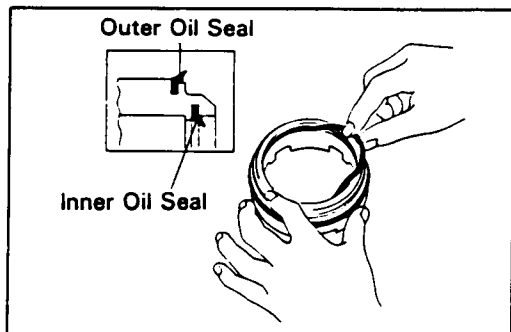

ASSEMBLY REAR SERVO PISTON

- (a) Apply ATF (DEXRON II) to new piston oil seal inner and outer rings.
 (b) Install the piston oil seal inner and outer rings to the servo piston.

NOTE: Be careful not to install new rings in the wrong direction.

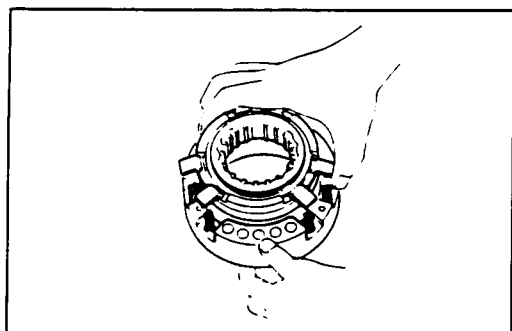

- (c) Install the six compression springs to the servo piston.
 (d) Apply MP grease to the clutch sleeve guide.
 (e) Install the clutch sleeve guide and retainer to the servo piston.

Torque: 50 kg-cm (43 in.-lb, 4.9 N·m)

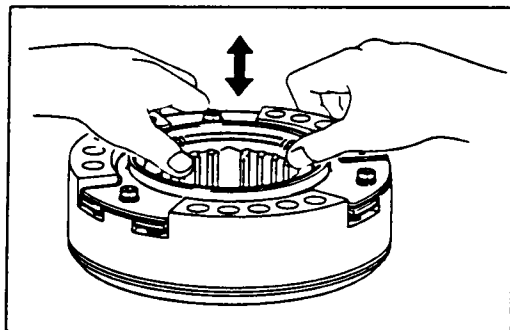

INSPECT REAR SERVO ASSEMBLY

Push the sleeve by hand and check that clutch sleeve guide slides smoothly in the servo piston.

Rear Valve Body

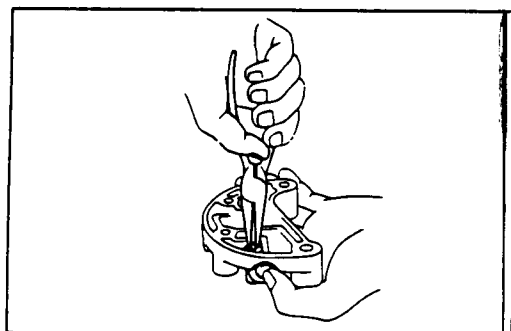
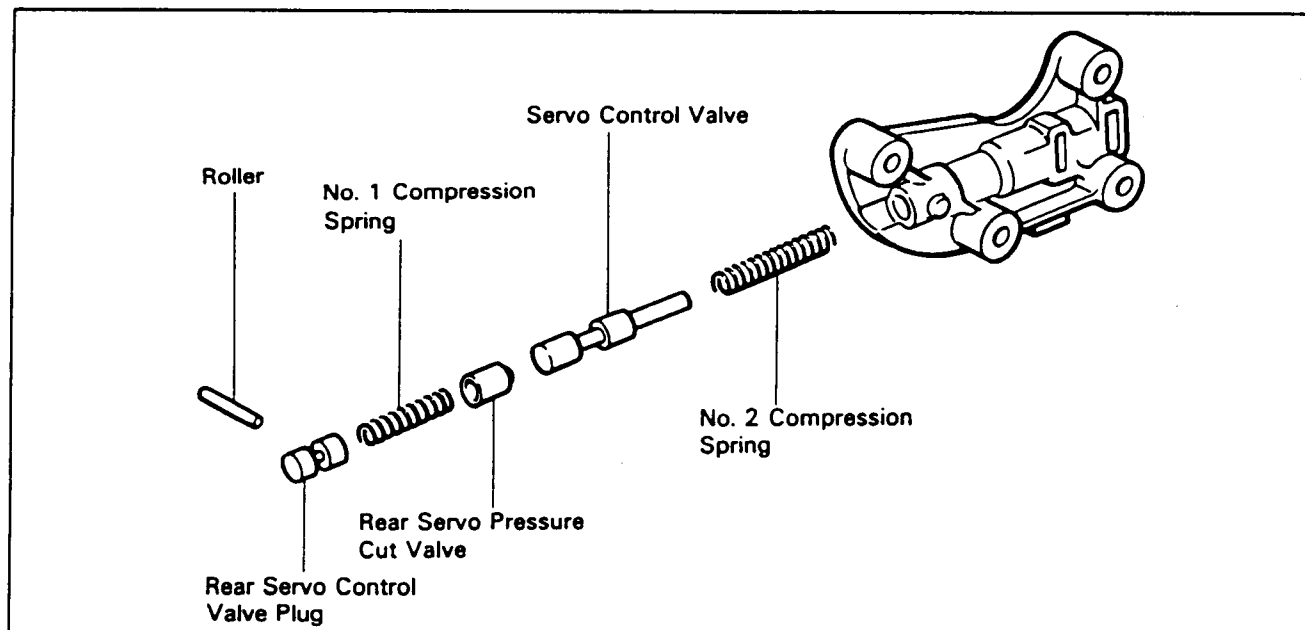

DISASSEMBLY OF REAR VALVE BODY

REMOVE PLUG VALVES AND SPRINGS

(a) Push the plug with your finger and remove the roller.

CAUTION: The spring is compressed so be careful that the valve does not fly out.

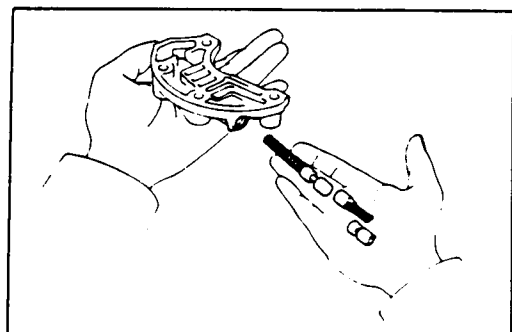

(b) Remove the rear servo control valve plug.

(c) Remove the No. 1 compression spring.

(d) Remove the rear servo pressure cut valve.

(e) Remove the servo control valve.

(f) Remove the No. 2 compression spring.

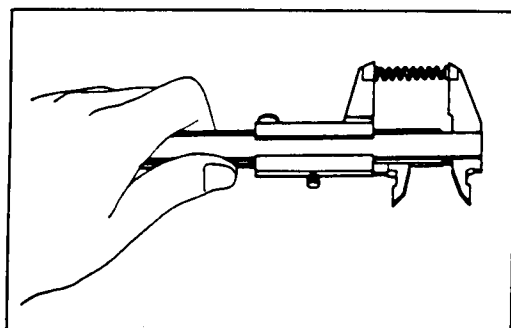

MEASURE TWO COMPRESSION SPRING FREE HEIGHT

(a) Measure the No. 1 compression spring free height.

Free length: 31.8 mm (1.252 in.)

(b) Measure the No. 2 compression spring free height.

Free length: 48.4 mm (1.906 in.)



Technical Service Information

ASSEMBLY OF REAR VALVE BODY

(See page AT-87)

INSTALL SPRINGS, VALVES AND PLUG

- (a) Apply ATF DEXRON II to each valve.
- (b) Install the No. 2 compression spring.
- (c) Install the rear servo control valve.
- (d) Install the rear servo pressure cut valve.
- (e) Install the No. 1 compression spring.
- (f) Install the rear servo control valve plug.

NOTE: Be careful not to assemble the valve in the wrong direction. The valve should slide smoothly by its own weight.

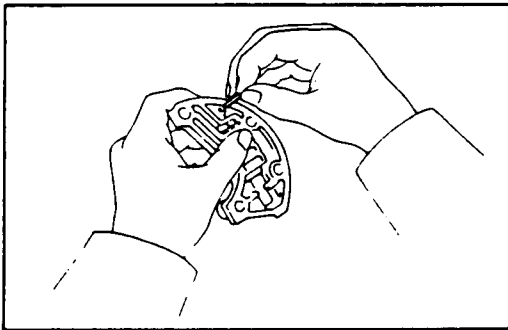
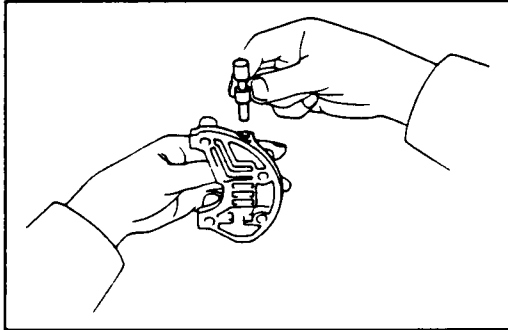

- (g) Push the valve by finger and install the roller.

Assembly of 4WD Change-over Mechanism

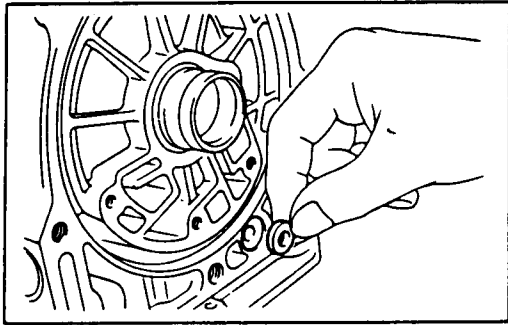

INSTALL APPLY GASKET

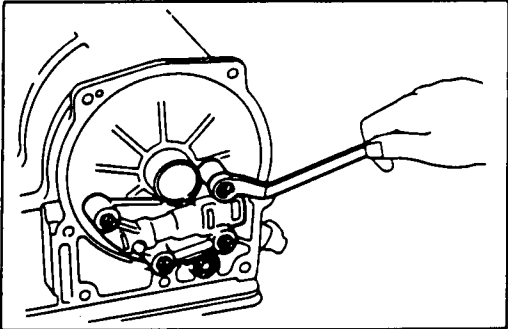

INSTALL REAR VALVE BODY

- (a) Install the valve body with two gaskets and plate to the transmission.
- (b) Torque the four bolts.

Torque: 55 kg-cm (48 in.-lb, 5.4 N·m)

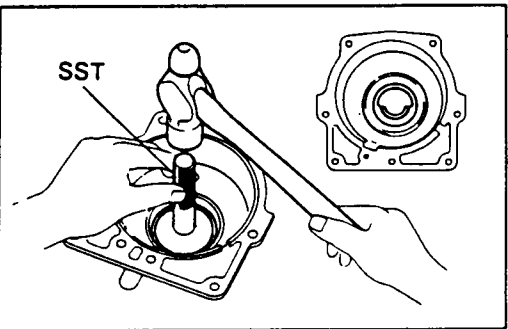

INSTALL REAR DRIVE SHAFT COVER

Using SST and a hammer, drive the drive shaft cover into the extension housing.

SST 09608-30011

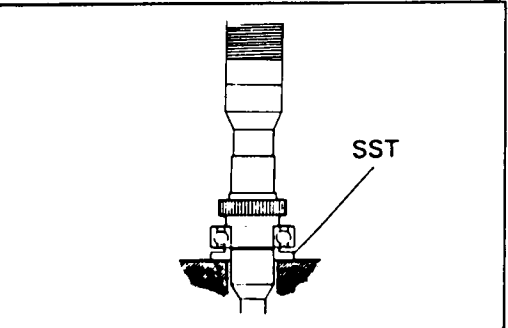

INSTALL OUTPUT SHAFT

- (a) Using SST and a press, install the radial ball bearing to the output shaft.

SST 09506-30011

- (b) Using snap ring pliers, install the snap ring to the output shaft.

- (c) Install the needle roller bearing and snap ring to the output shaft.

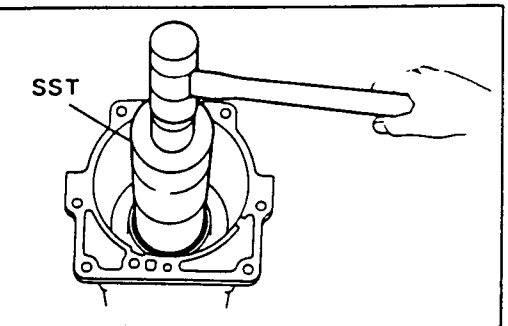

- (d) Using SST and a plastic hammer, install the output shaft to the extension housing.

SST 09316-60010

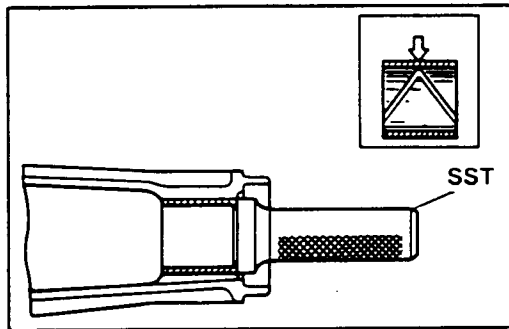

INSTALL EXTENSION HOUSING BUSHING

- (a) Heat the extension housing to 80 – 100°C (176 – 212°F).
- (b) Using SST and a hammer, install the bushing.
SST 09307-12010

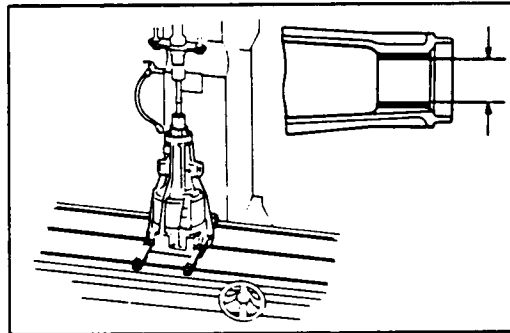

- (c) Using a honing machine, hone the inner surface of the bushing until standard inner diameter is obtained.

Standard inner diameter:

32.006 – 32.031 mm (1.2601 – 1.2611 in.)

- (d) Install the deflector to the extension housing.

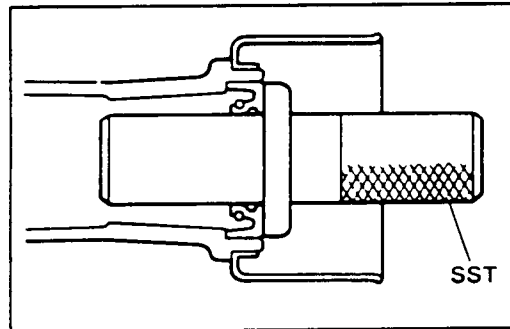

INSTALL EXTENSION HOUSING OIL SEAL

- (a) Using SST and a hammer, drive in the oil seal. (even with the surface of the housing)

SST 09325-12010

- (b) Apply MP grease to the oil seal lip.

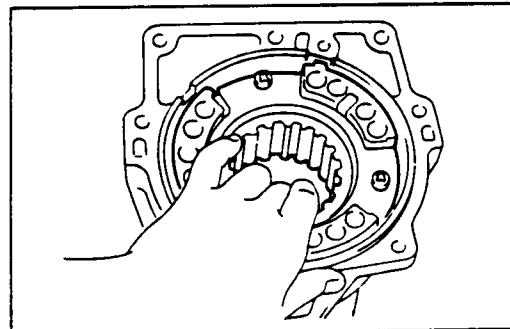

INSTALL REAR SERVO PISTON ASSEMBLY

- (a) Apply ATF (DEXRON II) to the extension housing and piston sliding parts.
- (b) Align the protruding part of the extension housing in the groove, and assemble the piston to the extension housing. Be careful not to damage the piston oil seal.

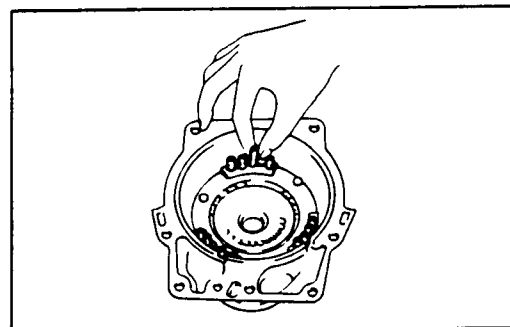

- (c) Install the twelve compression springs to the servo piston.
- (d) Clean the oil cleaner magnet and install it to the spring seat.

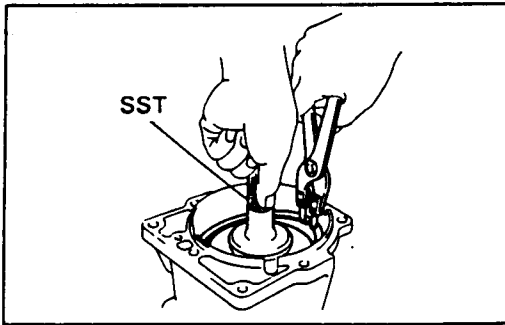

- (e) Install the spring seat on the rear servo piston.
- (f) Using SST, push down the spring seat and install the snap ring.

SST 09223-41020

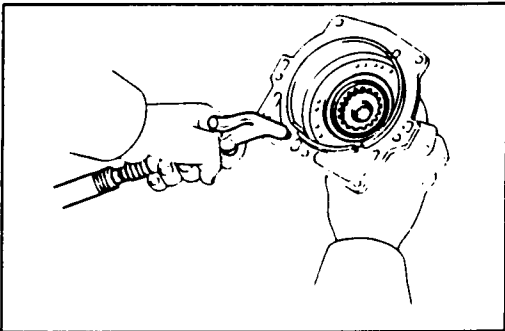

CHECK OPERATION OF REAR SERVO PISTON

- (a) Using compressed air (approx. 2 kg/cm², 28 psi or 196 kPa) confirm that the piston is fully seated against the return spring stopper.
- (b) Check the piston stroke.

Standard piston stroke: 10 mm (0.39 in.)

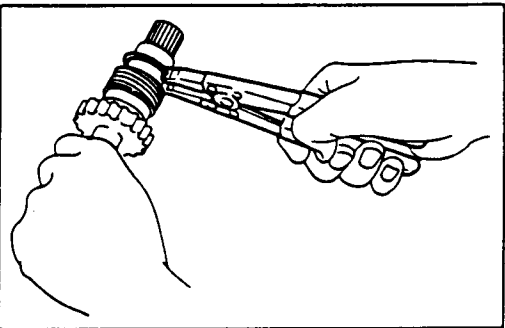

INSTALL SPEEDOMETER DRIVE GEAR

- (a) Install the locking ball and speedometer drive gear to the intermediate shaft.
- (b) Using snap ring pliers, install the snap ring.

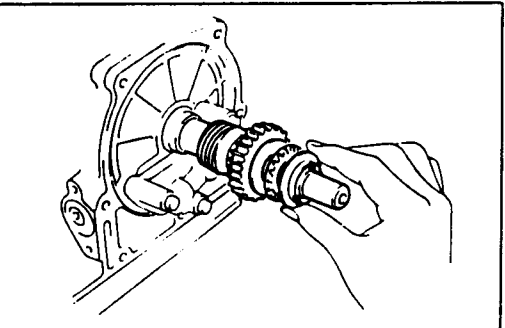

INSTALL INTERMEDIATE SHAFT

- (a) Install the intermediate shaft to the transmission.
- (b) Install the bearing race, bearing and bearing race.

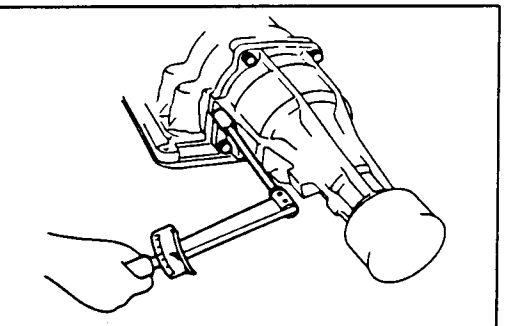

INSTALL EXTENSION HOUSING AND GASKET

Torque: 185 kg-cm (13 ft-lb, 18 N-m)

INSTALL SPEEDOMETER DRIVEN GEAR

INSTALL 4WD CHANGE-OVER SOLENOID



ASSEMBLY OF TRANSMISSION

Disassembly, inspection and assembly of each component group have been indicated in the preceding chapter. This chapter deals with assembly A55 transmission.

Before assembly, make sure again that all component groups are assembled correctly. If something wrong is found in a certain component group during assembly, inspect and repair this group immediately.

GENERAL ASSEMBLY NOTE:

1. The automatic transmission is composed of highly precision-finished parts, necessitating careful inspection before assembly because even a small nick could cause fluid leakage or affect performance.
2. Before assembling new clutch discs, soak them in automatic transmission fluid for at least two hours.
3. Apply automatic transmission fluid on sliding or rotating surfaces of the parts before assembly.
4. Use petroleum jelly to keep the small parts in their places.
5. Do not use adhesive cements on gaskets and similar parts.
6. When assembling the transmission, be sure to use new gaskets and O-rings.
7. Dry all parts by blowing them with compressed air. Never use shop rags.
8. Be sure to install the thrust bearings and races in the correct direction and position.

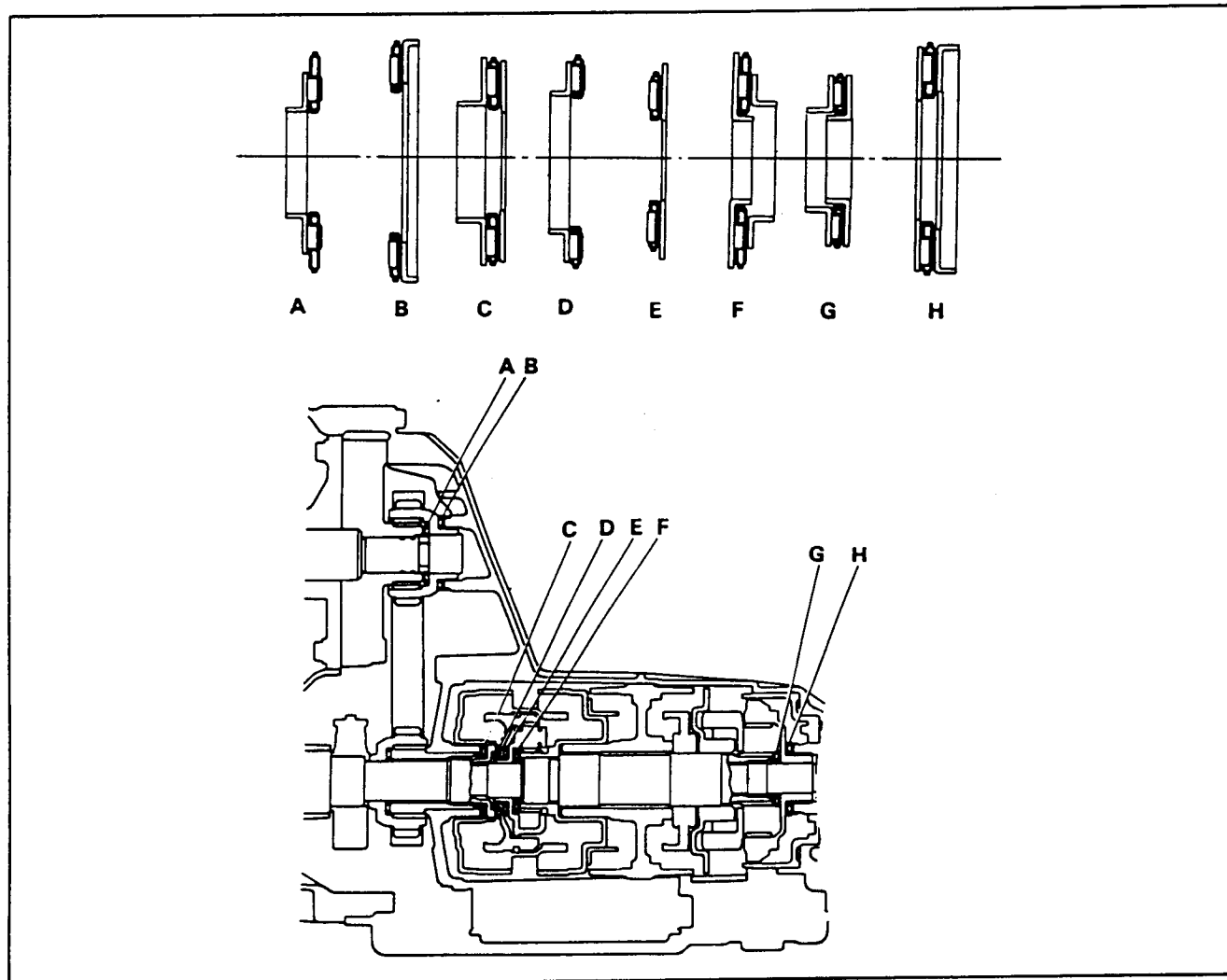

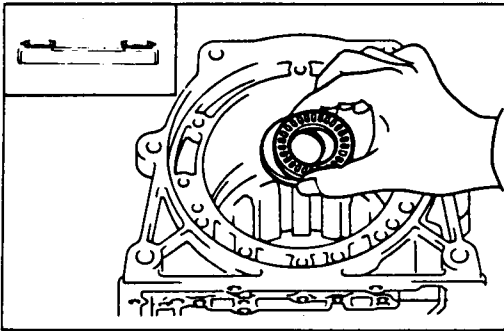

INSTALL THRUST WASHER AND BEARING

Install the thrust washer, facing the cup side downward.

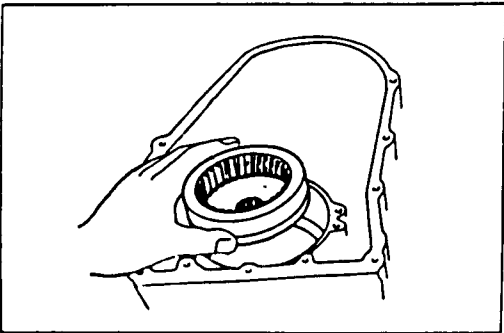

INSTALL REAR PLANETARY RING GEAR

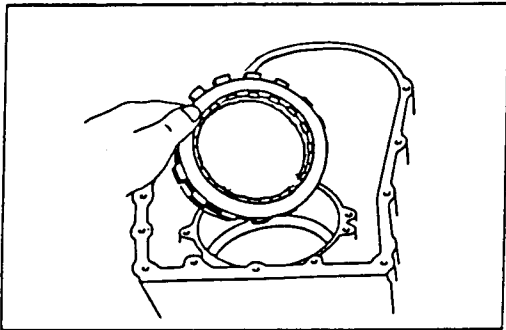

INSTALL NO. 3 BRAKE CUSHION PLATE, DISC AND PLATE

Be sure to assemble the brake cushion plate in the correct direction.

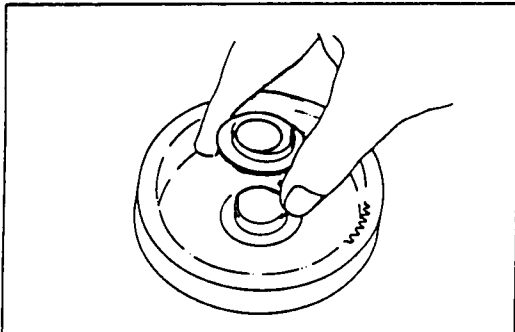

INSTALL THRUST BEARING

Coat the race with petroleum jelly and stick it onto the ring gear.

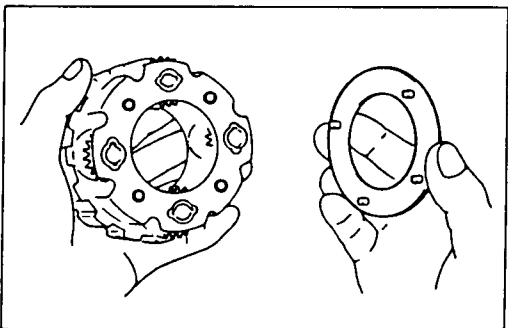

INSTALL REAR PLANETARY GEAR AND THRUST WASHER

- (a) After aligning the notch and tab, coat the thrust washer with petroleum jelly and stick it onto the planetary gear.

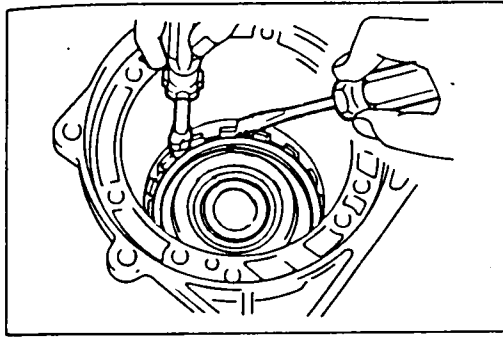

(b) Before assembling the planetary gear, align the disc flukes.

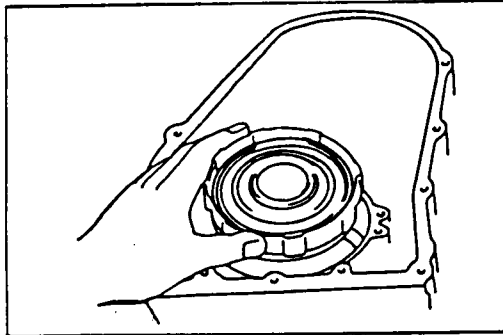

(c) Install the rear planetary gear.

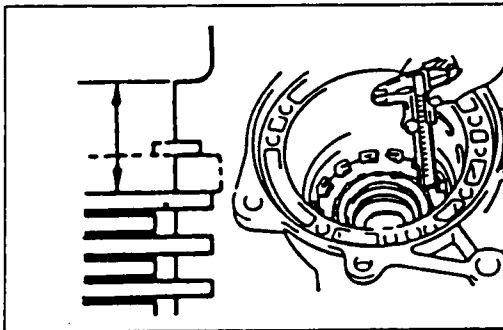

MEASURE NO. 3 BRAKE CLEARANCE

To prevent the plate from tilting while measuring, hold it down with two hammer handles.

Standard clearance: **10.04 – 11.30 mm**
(0.3953 – 0.4449 in.)

INSTALL REACTION PLATE

Align the portion of the reaction plate marked "A" with the "B" portion of the transmission case.

NOTE: Groove "B" is larger than the other grooves.

The reaction plate is correctly installed if the snap ring groove is fully visible.

INSTALL SNAP RING

Use a large screwdriver to compress the snap ring. Push it into the place by hand. Work around the case. Visually check to make sure that the ring is fully seated. Make sure that the ends of the snap ring are between the lugs.

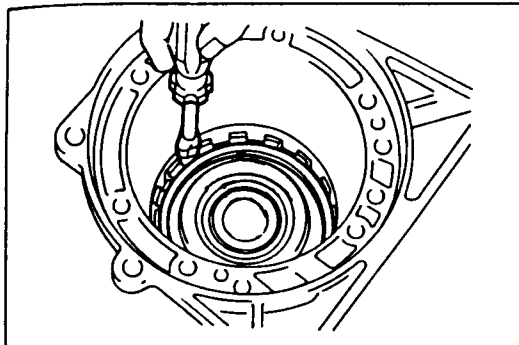

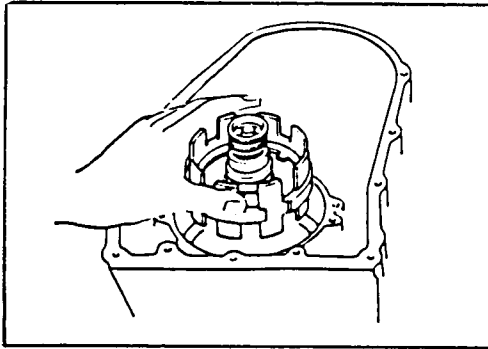
**PUSH CENTER SUPPORT ASSEMBLY INTO CASE**

Align the oil hole and bolt hole of the center support with those of the body side and insert.

INSTALL TWO CENTER SUPPORT BOLTS WITH WAVE WASHERS

Align the center support with holes in the case and install the two bolts finger tight.

TIGHTEN TWO CENTER SUPPORT BOLTS

- (a) Tighten the bolts alternately in 70 kg-cm (61 in.-lb, 6.9 N·m) increments.

Torque: 260 kg-cm (19 ft-lb, 25 N·m)

- (b) Confirm that the sun gear turns lightly in clockwise direction and heavily in counterclockwise direction.

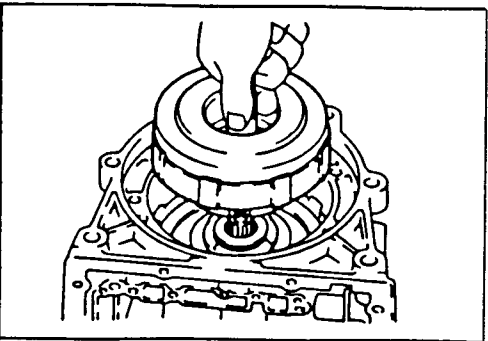
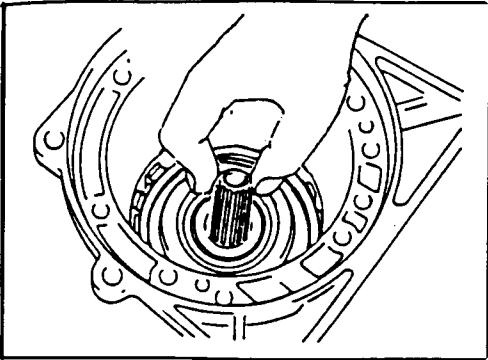
**INSTALL REAR CLUTCH IN CASE**

Rotate the clutch to mesh the hub with the center support.

NOTE: Confirm that the B₁ brake is securely meshed with the rear clutch drum. Approx 4 mm (0.16 in.) depth from sun gear to shaft.

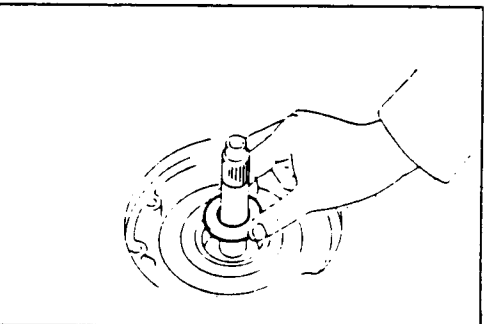
**INSTALL THRUST BEARING RACE**

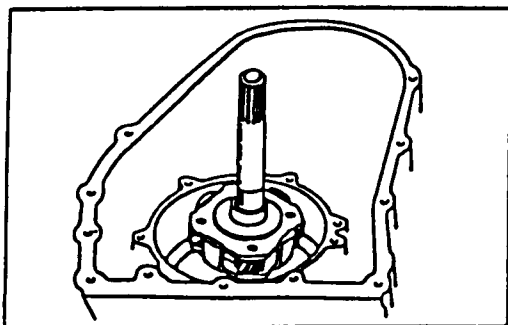

INSTALL OUTPUT SHAFT AND FRONT PLANETARY GEAR

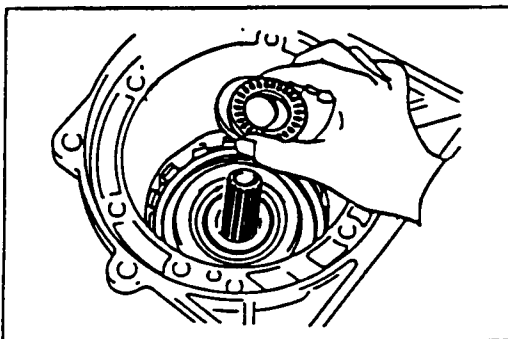

INSTALL THRUST BEARING AND RACE

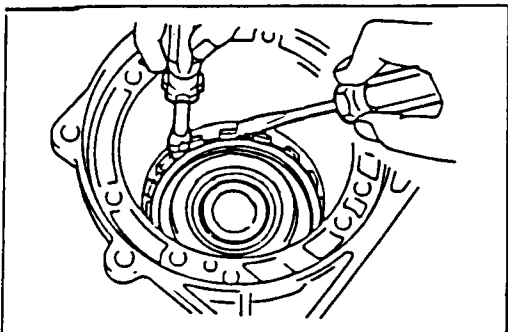

INSTALL FRONT CLUTCH ASSEMBLY IN CASE

Align the flukes of the rear clutch discs and mesh them with the front clutch hub. Push the front clutch assembly into the case.

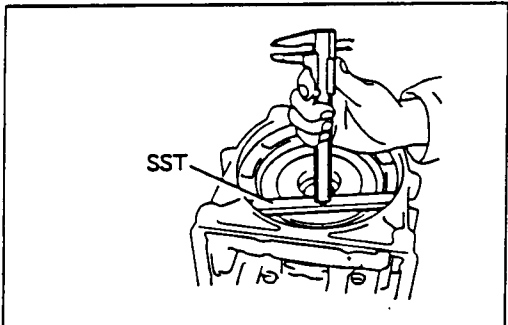

CHECK CORRECT INSTALLATION OF FRONT CLUTCH

Set SST on the transmission case as shown in the figure. Measure the distance between the top surface of the case and front clutch assembly. If the distance corresponds to specification, the front clutch is installed correctly.

SST 09350-20013

Height: 0.6 – 1.6 mm (0.024 – 0.063 in.)

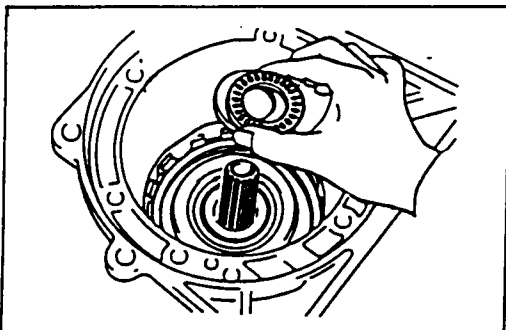

INSTALL THRUST BEARING AND RACE

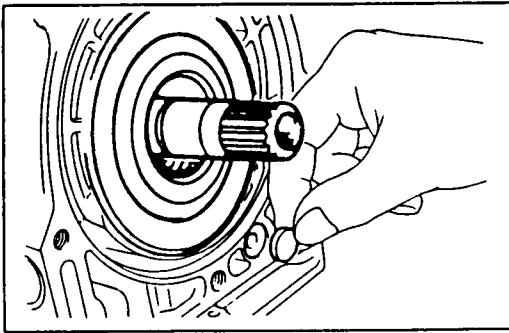

INSTALL O-RING ON CASE

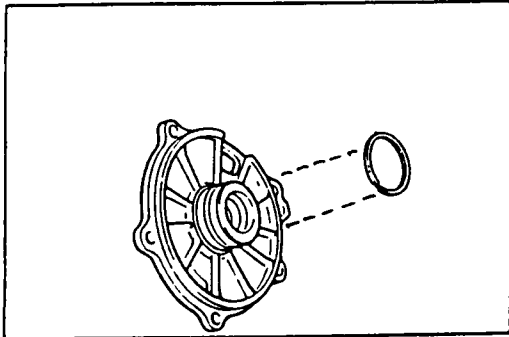

INSTALL THRUST WASHER ON FRONT SUPPORT

Coat the thrust washer with petroleum jelly and set it into place, facing the lip side toward the front support.

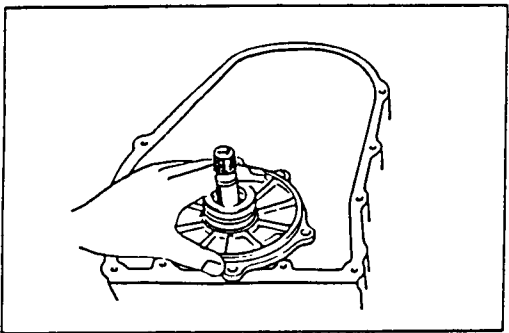

INSTALL FRONT SUPPORT ON CASE

- (a) Install the front support to the case and confirm that there is no clearance between the surfaces of the support and case when pressing down with your hand.

NOTE: If there is a clearance, the front clutch is not completely installed.

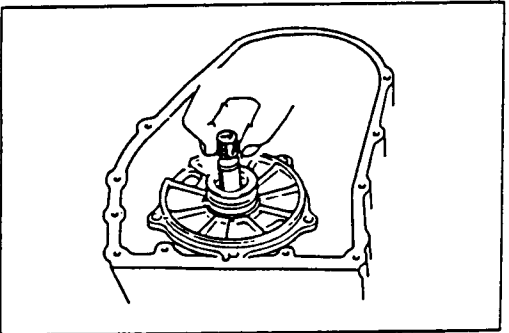

- (b) Confirm that there is thrust play on the input shaft and tighten the bolts in diagonal order.

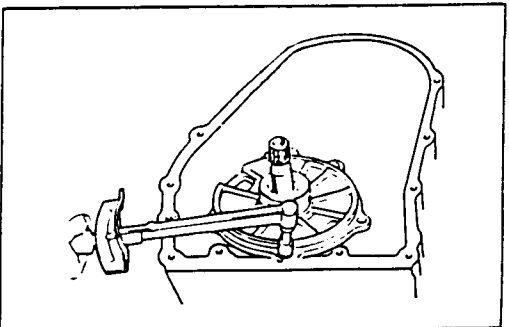

- (c) Tighten the bolts a little at a time in two or three stages and in diagonal order.

Torque: 195 kg-cm (14 ft-lb, 19 N·m)

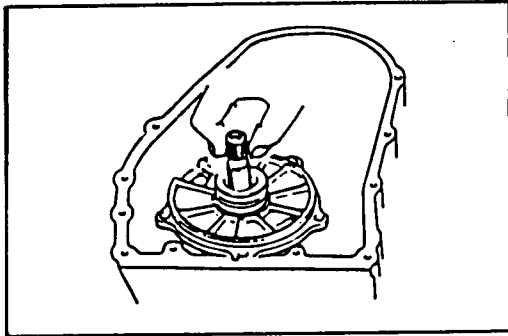

CHECK FRONT CLUTCH INPUT SHAFT AND OUTPUT SHAFT

(a) Make sure that the front clutch input shaft has play in axial direction and that it turns.

Thrust play: 0.24 – 0.96 mm (0.0094 – 0.0378 in.)

(b) Make sure that the output shaft has thrust play in axial direction.

Thrust play: 0.31 – 1.53 mm (0.0122 – 0.0602 in.)

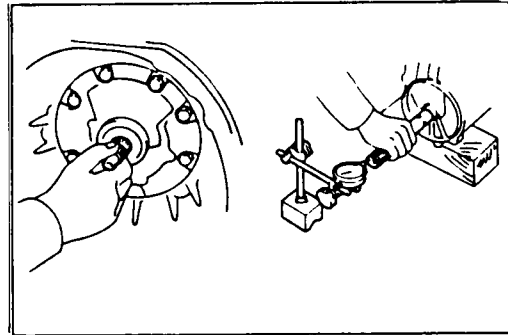

INSTALL BEARING ON DRIVE SPROCKET

INSTALL THRUST RACE ON CASE

Coat the thrust race with petroleum jelly and install the lip side toward the case.

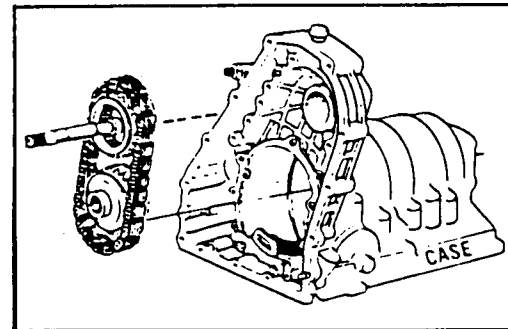

INSTALL INPUT SHAFT, DRIVE SPROCKET CHAIN AND DRIVEN SPROCKET

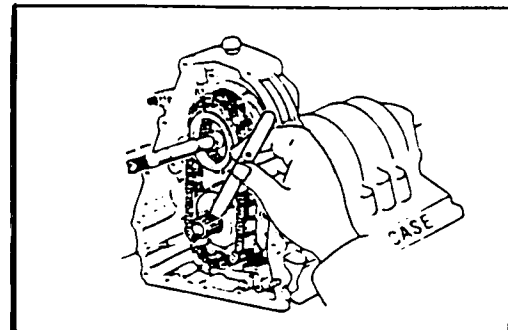

INSTALL SNAP RING

CHECK CLEARANCE BETWEEN SNAP RING AND DRIVEN SPROCKET

Thrust clearance:

0.11 – 0.69 mm (0.0043 – 0.0272 in.)

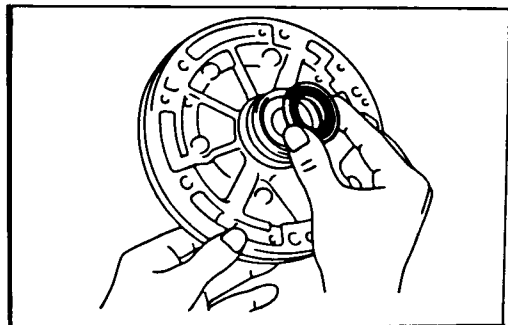

INSTALL THRUST RACE ON OIL PUMP

Coat the thrust race with petroleum jelly and install the lip side toward the pump body.



Technical Service Information

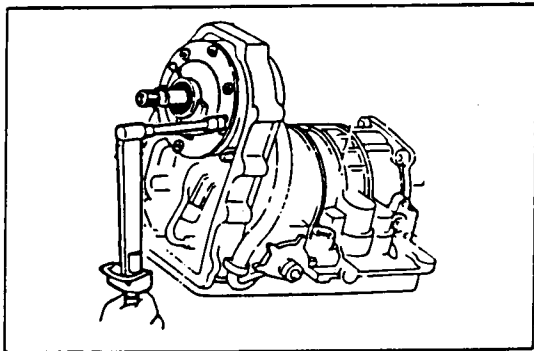

INSTALL OIL PUMP

Tighten the set bolts gradually and evenly.

Torque: 185 kg-cm (13 ft-lb, 18 N·m)

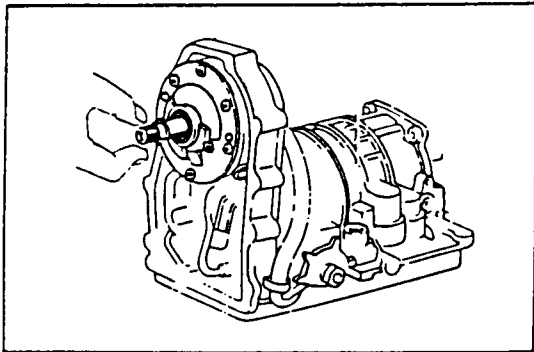

CHECK OIL PUMP

Confirm that the drive gear rotates smoothly.

NOTE: Do not damage the oil seal lip.

CHECK INPUT SHAFT

Make sure that the input shaft has play in axial direction and that it turns.

Thrust play: 0.10 – 0.70 mm
(0.0039 – 0.0276 in.)

INSTALL TUBE AND O-RING

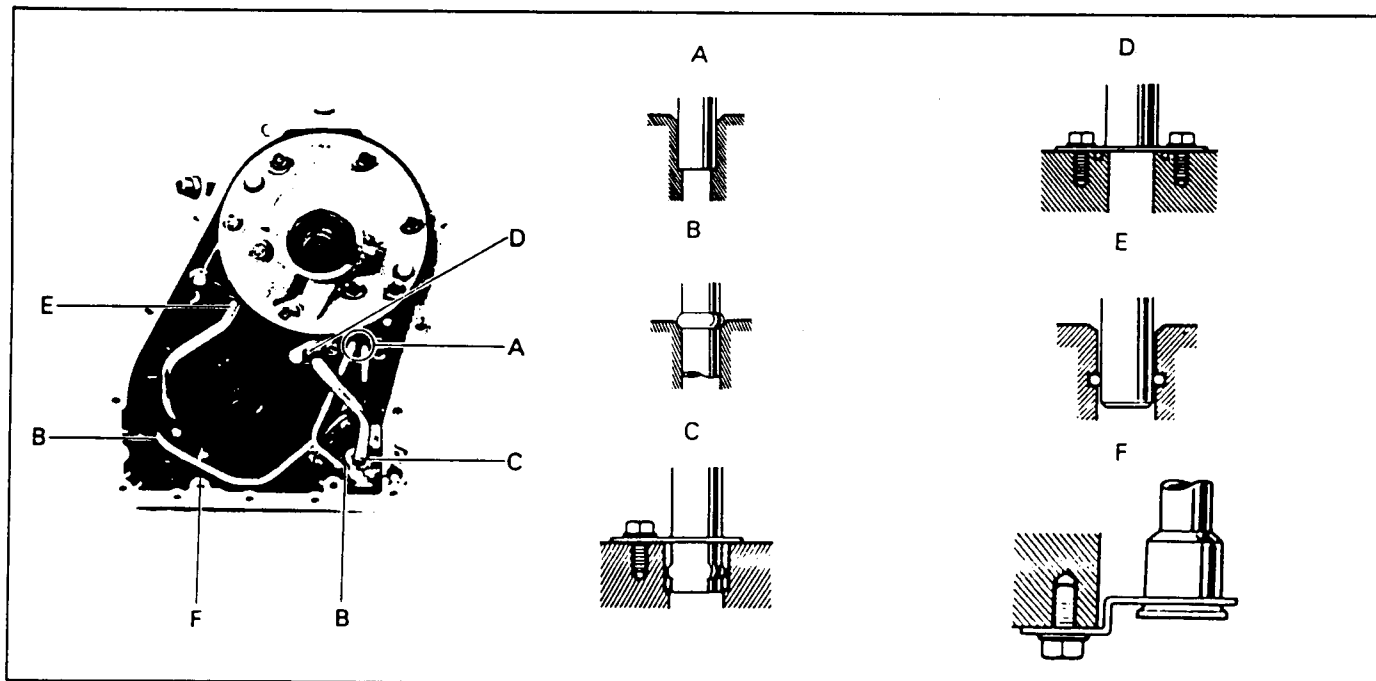

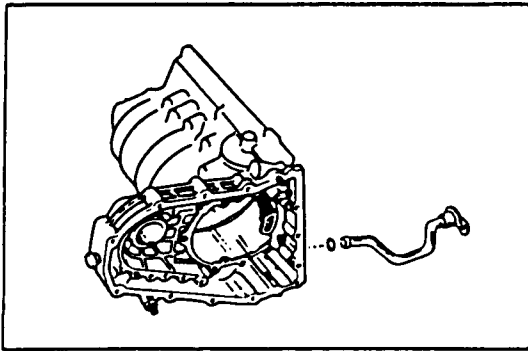

(a) Temporarily tighten the suction tube bracket.

NOTE: Always use a new O-ring.

Drive in the tube until it makes contact with either the bulge or the stopper.

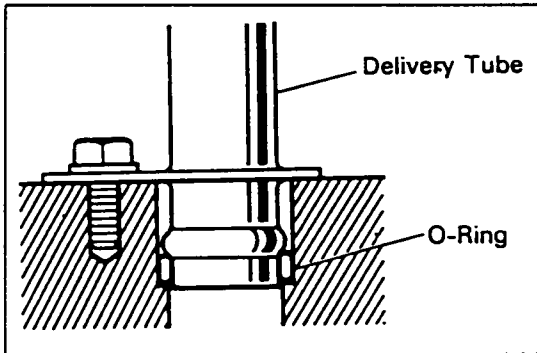

(b) After installing the O-ring on the delivery tube, install the tube into the transmission case.

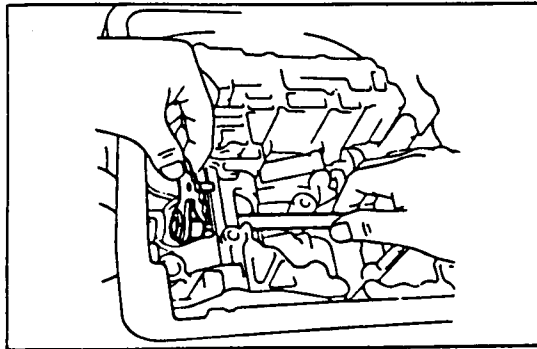

INSTALL MANUAL VALVE LEVER SHAFT INTO CASE

(a) Assemble a new spacer to the manual valve lever.

NOTE: Always replace the spacer and slotted spring pin with a new one. Never reuse a slotted spring pin after it has been removed.

(b) Install the manual valve lever.

(c) While holding the ditent ball with the plate, install the manual valve shaft.

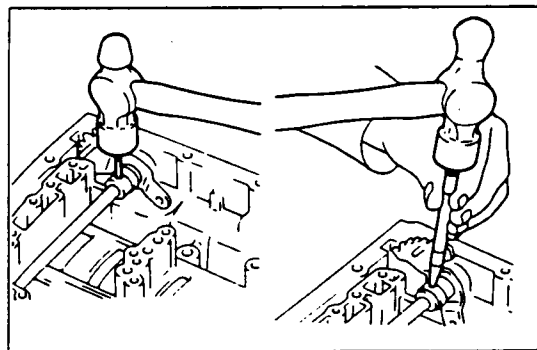

(d) Drive in the slotted spring pin.

(e) After assembly, turn the spacer 90° and stake it.

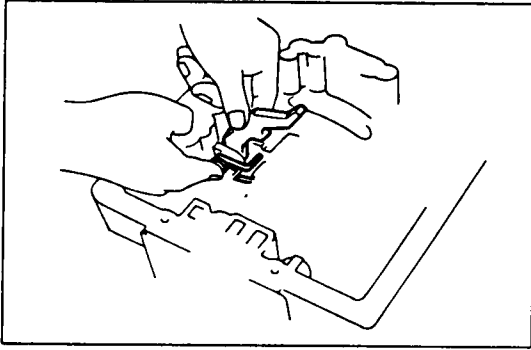
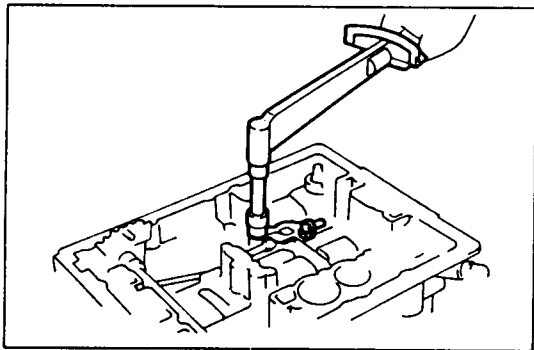
**INSTALL PARK PAWL, PIVOT PIN AND SPRING IN CASE****INSTALL PARK PAWL BRACKET ON CASE**

Make sure the collar on the parking lock rod is facing toward the front of the transmission.

Tighten the two bolts. Make sure the pawl moves freely.

NOTE: It is possible for the bracket to be installed too far forward, where it will bind the pawl.

Torque: 75 kg-cm (65 in.-lb, 7.4 N·m)

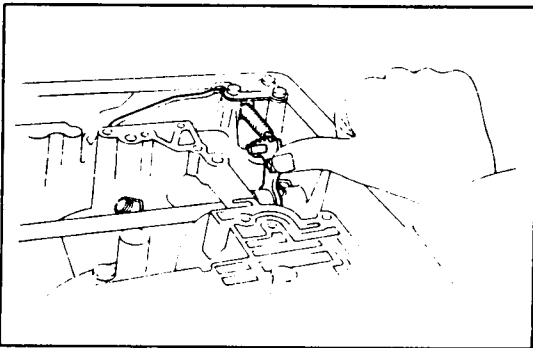
**CHECK OPERATION OF PARK LOCK PAWL**

Make sure the planetary gear output shaft is locked when the manual valve lever is in the "P" range.

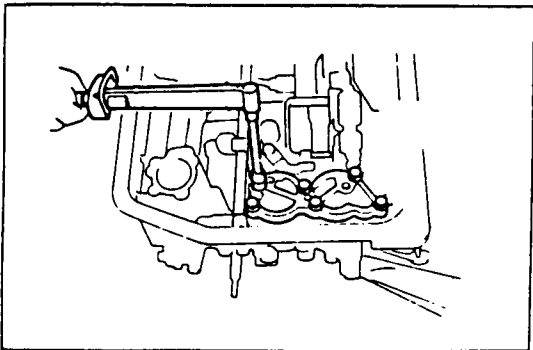
**INSTALL ACCUMULATOR PISTON AND SPRINGS**

(a) Be sure to install the accumulator spring and piston in correct direction.

(b) Fully install the pistons into the cylinder by hand.

(c) Be sure to assemble the gasket in correct direction.

(d) Install the cover.

Torque: 55 kg-cm (48 in.-lb, 5.4 N·m)

● CHECK BALL LOCATIONS

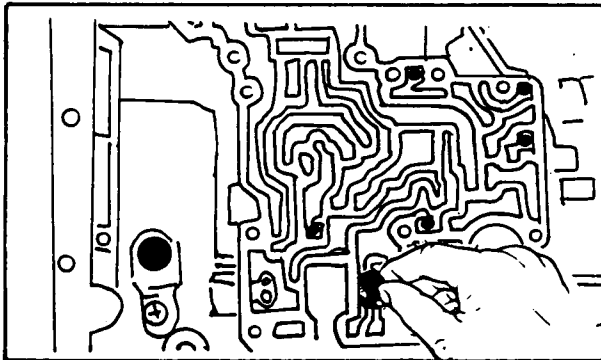
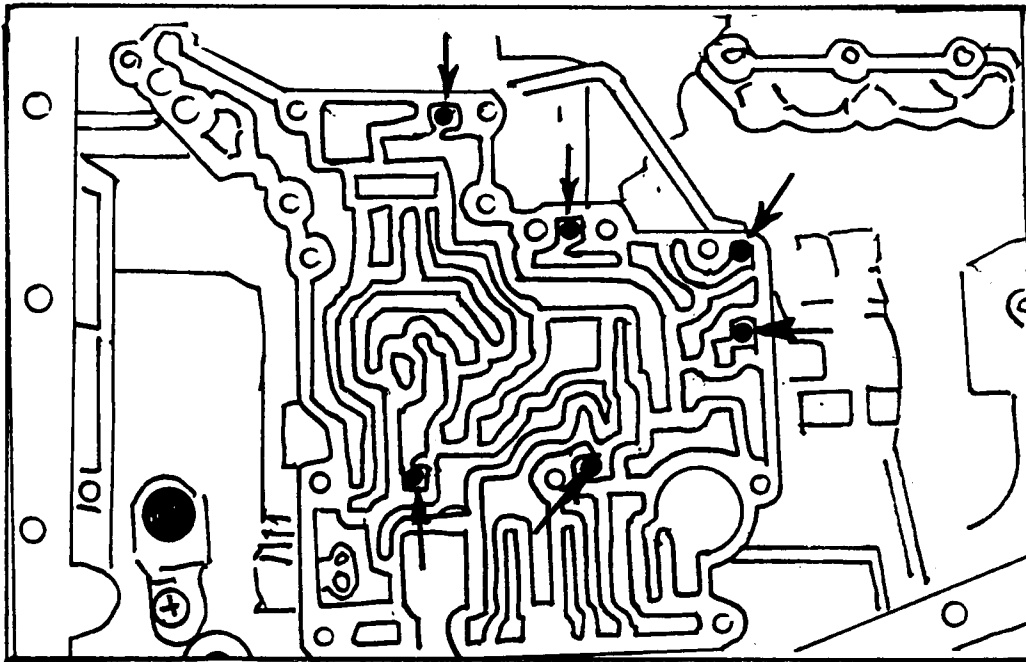

INSTALL VALVE BODY PLATE, GASKET VALVE BODY AND OIL STRAINER

- (a) Before installing the gasket, make sure the vibrating stopper is installed.

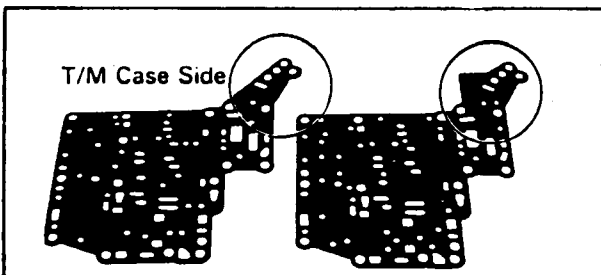

- (b) Do not interchange the upper and lower gaskets.

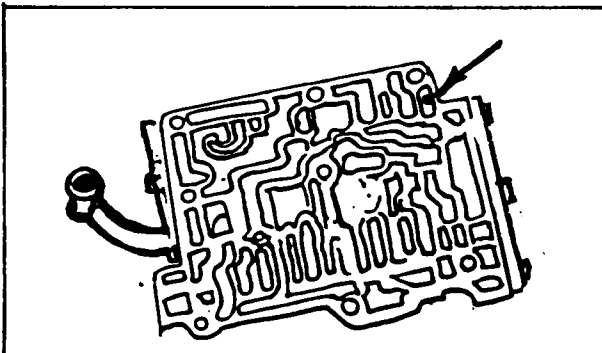

- (c) Before assembling the valve body, confirm that the cut back plug lock pin has not fallen out.

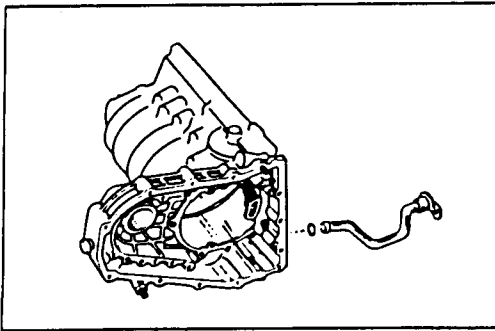

- (d) Connect the oil pump suction pipe and assemble the valve body to the upper case.

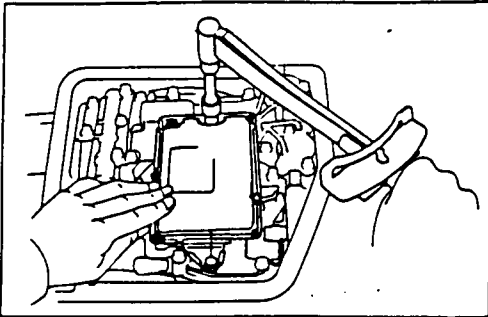

- (e) Gradually tighten the bolts in diagonal order.
Torque: 55 kg-cm (48 in.-lb, 5.4 N·m)
NOTE: Also tighten the suction pipe bracket bolt.

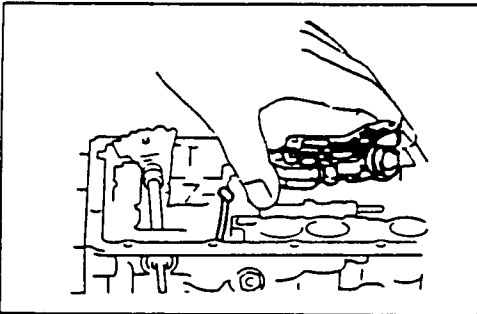

INSTALL FRONT VALVE BODY AND ROD

- (a) Connect the manual valve connecting rod and manual valve, and then assemble the valve body.

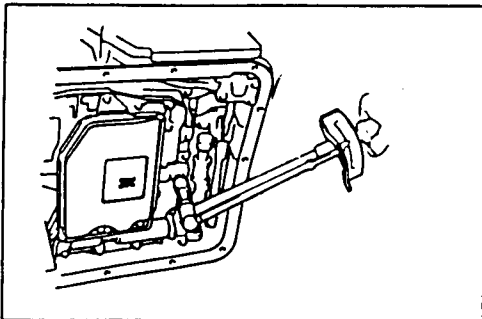

- (b) Gradually tighten the bolts in 3 or 4 stages.
Torque: 55 kg-cm (48 in.-lb, 5.4 N·m)

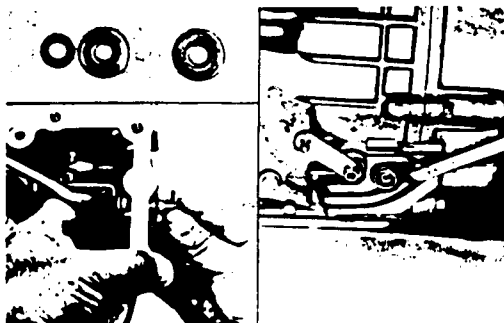

41. INSTALL THROTTLE LEVER

- (a) Assemble one regular washer and one wave washer on the inside of the throttle lever and one regular washer on the outside.
 (b) Check the thrust clearance after assembling the throttle lever.

Thrust clearance: Less than 0.50 mm (0.0197 in.)

If the clearance is more than 0.50 mm (0.0197 in.), insert a washer on the outer side.

- (c) Install the throttle cover.

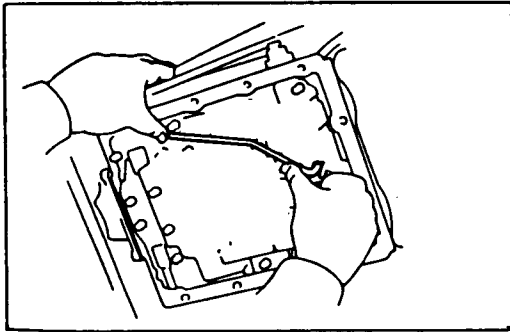

INSTALL OIL TUBES

Press the tubes by hand into the positions indicated in the figure.

CAUTION: Be careful not to bend or damage the tubes.

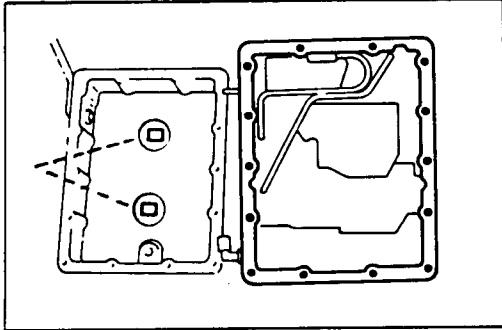

INSTALL MAGNETS IN PAN AND INSTALL OIL PAN WITH NEW GASKET

- Clean the magnets and install a new gasket in the proper position.
- Prior to installing the oil pan, confirm that the tube will not interfere with it.

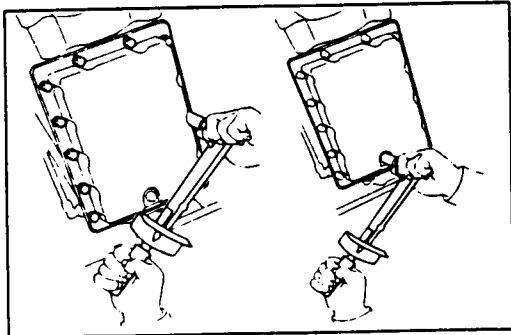

- Tighten the bolts.

Torque: 75 kg-cm (65 in.-lb, 7.4 N·m)

INSTALL DRAIN PLUG WITH NEW GASKET

Torque: 300 kg-cm (22 ft-lb, 29 N·m)

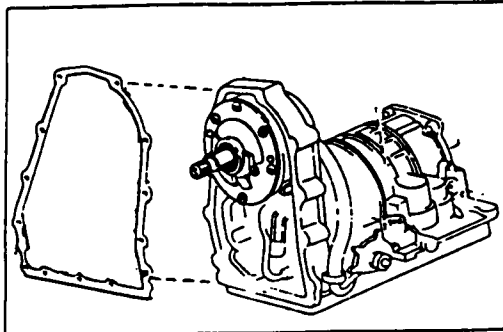

INSTALL TRANSAXLE GASKET AND GOVERNOR APPLY GASKET

Before assembling the transaxle, confirm that the governor apply gasket has not fallen out.

ASSEMBLE TRANSAXLE

Tighten the transmission mounting bolts.

Torque: 195 kg-cm (14 ft-lb, 19 N·m)

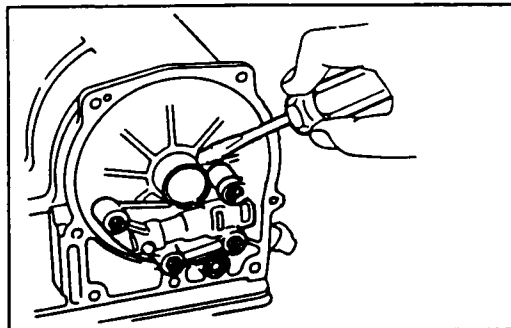

INSTALL OUTPUT SHAFT SLEEVE

- Install the oil seal ring to the output shaft sleeve.
- Install the output shaft sleeve to the output shaft. Push in the oil seal ring with a screwdriver.

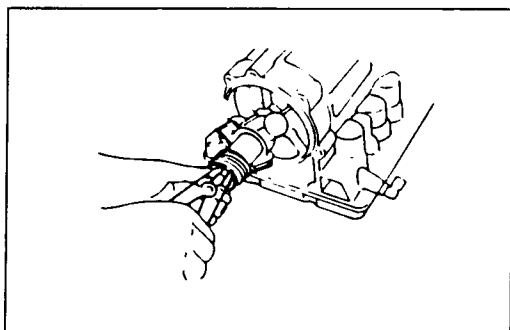

INSTALL SPEEDOMETER DRIVE GEAR AND SNAP RING

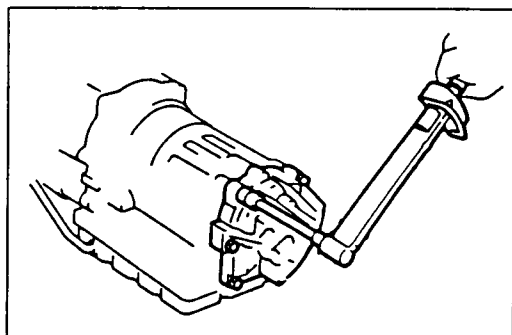

INSTALL REAR EXTENSION HOUSING WITH NEW GASKET

Torque: 195 kg-cm (14 ft-lb, 19 N·m)

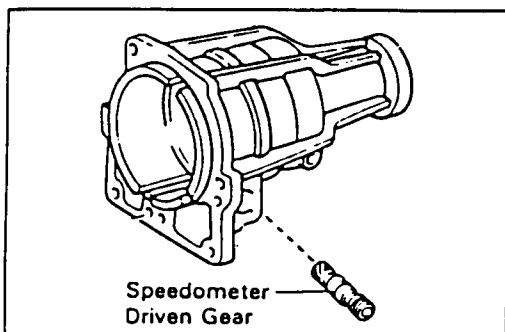

INSTALL O-RINGS, BUSHING AND SPEEDOMETER DRIVEN GEAR TO SHAFT SLEEVE

INSTALL SPEEDOMETER DRIVEN GEAR ASSEMBLY IN EXTENSION HOUSING

Insert the shaft sleeve assembly into the housing. Install the lock plate with a bolt and lock washer.

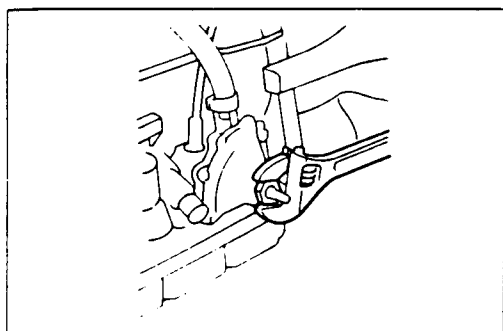

INSTALL NEUTRAL START SWITCH

- Slide the neutral start switch onto the control shaft.
- Install the grommet facing the groove toward the switch body and then install the washer and nut.
- Move the switch so that the slit in the switch and neutral base line match. Tighten the bolt and nut.

Torque: Nut 70 kg-cm (61 in.-lb, 6.9 N·m)
Bolt 130 kg-cm (10 ft-lb, 13 N·m)

INSTALL SHIFT HANDLE

INSTALL FILLER TUBE

- Replace the O-ring and push the tube into place.
- Install the filler tube with the bolt.

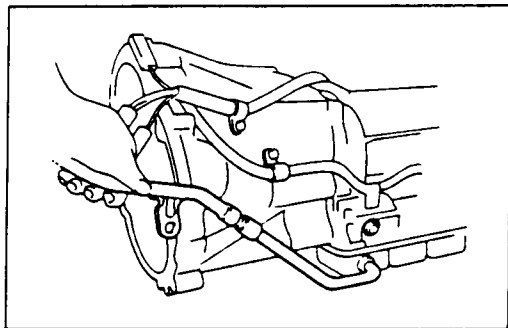

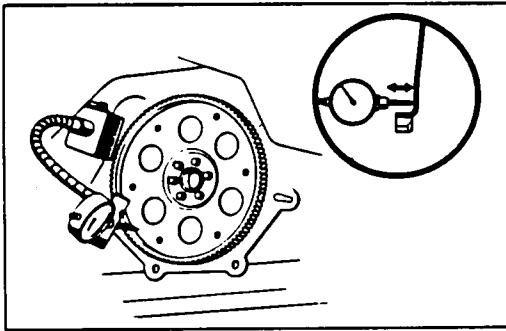
**MEASURE DRIVE PLATE RUNOUT AND INSPECT RING GEAR**

Set up a dial indicator and measure the drive plate runout. If runout exceeds 0.20 mm (0.0079 in.) or if the ring gear is damaged, replace the drive plate. If installing a new drive plate, note the orientation of spacers and tighten the bolts.
Torque: 650 kg-cm (47 ft-lb, 64 N·m)

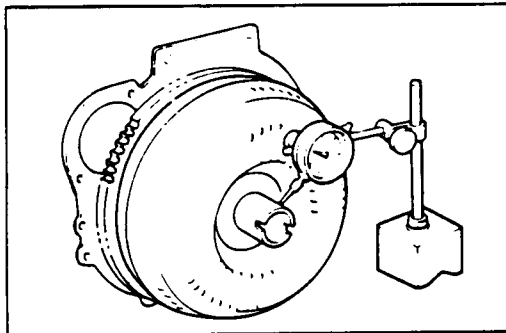
**MEASURE TORQUE CONVERTER SLEEVE RUNOUT**

(a) Temporarily mount the torque converter to the drive plate. Set up a dial indicator.

If runout exceeds 0.30 mm (0.0118 in.), try to correct by reorienting the installation of the converter. If excessive runout cannot be corrected, replace the torque converter.

NOTE: Mark the position of the converter to ensure correct installation.

(b) Remove the torque converter.

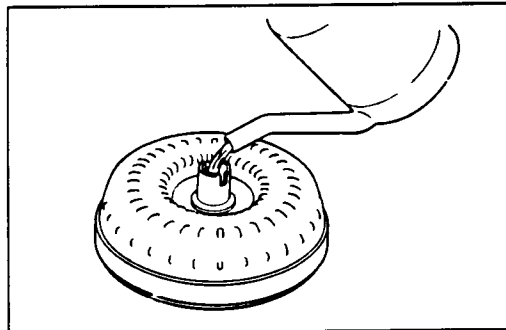
**INSTALL TORQUE CONVERTER IN TRANSMISSION**

If the torque converter has been drained and washed, refill with fresh ATF.

ATF capacity: 1.0 liters (1.1 US qts, 0.9 Imp. qts)

Fluid type: ATF DEXRON II

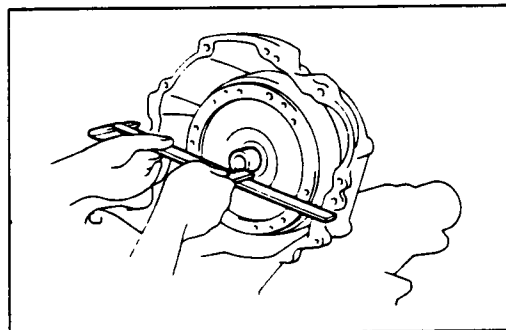
**CHECK TORQUE CONVERTER INSTALLATION**

Using calipers and a straight edge, measure from the installed converter center piece surface to the front surface of the transmission housing.

Correct distance: More than 8 mm (0.31 in.)